

# VENTECH GRILLES



## **ABOUT US**

**VENTECH VENTILATION CO LTD** IS ONE OF THE LEADING MANUFACTURERS IN CHINA SELLING ITS PRODUCTS IN 30 COUNTRIES.

**VENTECH (AUSTRALIA) PTY LTD** IS A JOINT VENTURE COMPANY MANUFACTURING GRILLES AND DIFFUSERS IN AUSTRALIA TO ACHIEVE FASTER DELIVERY TIMES.

THE DECISION TO MANUFACTURE LOCALLY WAS THE RESULT OF HIGH DEMAND FOR VIRTUAL HIGH QUALITY PRODUCTS AND TO OFFER PROMPT SERVICE TO OUR CUSTOMERS.

### **OUR MISSION STATEMENT**

GOOD QUALITY

GOOD PRICE

GOOD SERVICE

WE WILL SEEK CUSTOMERS THAT HAVE SIMILAR VALUES TO US.

FROM OUR PREMISES AT 25 KEMBLA STREET, CHELTENHAM, WE AIM TO BECOME A NATIONAL COMPANY IN THE SHORTEST POSSIBLE TIME AND ARE COMMITTED TO OFFER OUR CLIENTS GOOD PRICES, GOOD QUALITY AND GOOD SERVICE TO ACHIEVE OUR GOALS.

VENTECH ENGINEERS WILL WORK TO DEVELOP NEW DESIGN AND TECHNOLOGIES TO ACHIEVE BETTER PRODUCT PERFORMANCE, EASIER TO INSTALL AND HIGHER QUALITY YEAR ON YEAR.

OUR WARRANTY AGAINST DEFECTS IS:

### **WE WILL**

- REPAIR OR REPLACE THE GOODS PROMPTLY
- REPLACE OR RECTIFY THE SERVICES
- WHOLLY OR PARTLY COMPENSATE THE CUSTOMER

**VENTECH PERSONNEL WILL ALWAYS COOPERATE WITH THE CUSTOMER TO MAKE DOING BUSINESS TOGETHER AN EFFICIENT, FAST AND PLEASANT EXPERIENCE.**

## **INDEX**

---

|  |       |     |
|--|-------|-----|
| Supply Air Lay In Diffuser                     | ..... | P5  |
| Supply Air Ceiling Grille (T-bar)              | ..... | P15 |
| Curved Blade Diffuser                          | ..... | P17 |
| Bevelled Edge Diffuser                         | ..... | P21 |
| Swirl Diffuser                                 | ..... | P28 |
| Round Ceiling Diffuser                         | ..... | P33 |
| Jet Diffuser                                   | ..... | P35 |
| Jetflo Diffuser                                | ..... | P37 |
| Linear Slot Diffuser                           | ..... | P39 |
| Linear Slot Diffuser Frame Support             | ..... | P43 |
| Hinged Eggcrate Grille with Removable Filter   | ..... | P49 |
| Eggcrate Grille with Fixing Clip Reducing Neck | ..... | P50 |
| Half Chevron Louvre                            | ..... | P53 |
| Door Grille                                    | ..... | P56 |
| Weather Proof Louvre                           | ..... | P62 |
| Linear Bar Grille                              | ..... | P68 |
| Flangeless Linear Bar Grille                   | ..... | P70 |
| Single Deflection Grille                       | ..... | P72 |
| Double Deflection Grille                       | ..... | P74 |
| Jet Nozzle Diffuser                            | ..... | P76 |
| Butterfly Damper                               | ..... | P79 |
| Opposite Blades Damper                         | ..... | P80 |
| Volume Control Damper                          | ..... | P81 |
| Motorised Zone Damper                          | ..... | P82 |
| Stream Splitter Damper                         | ..... | P83 |

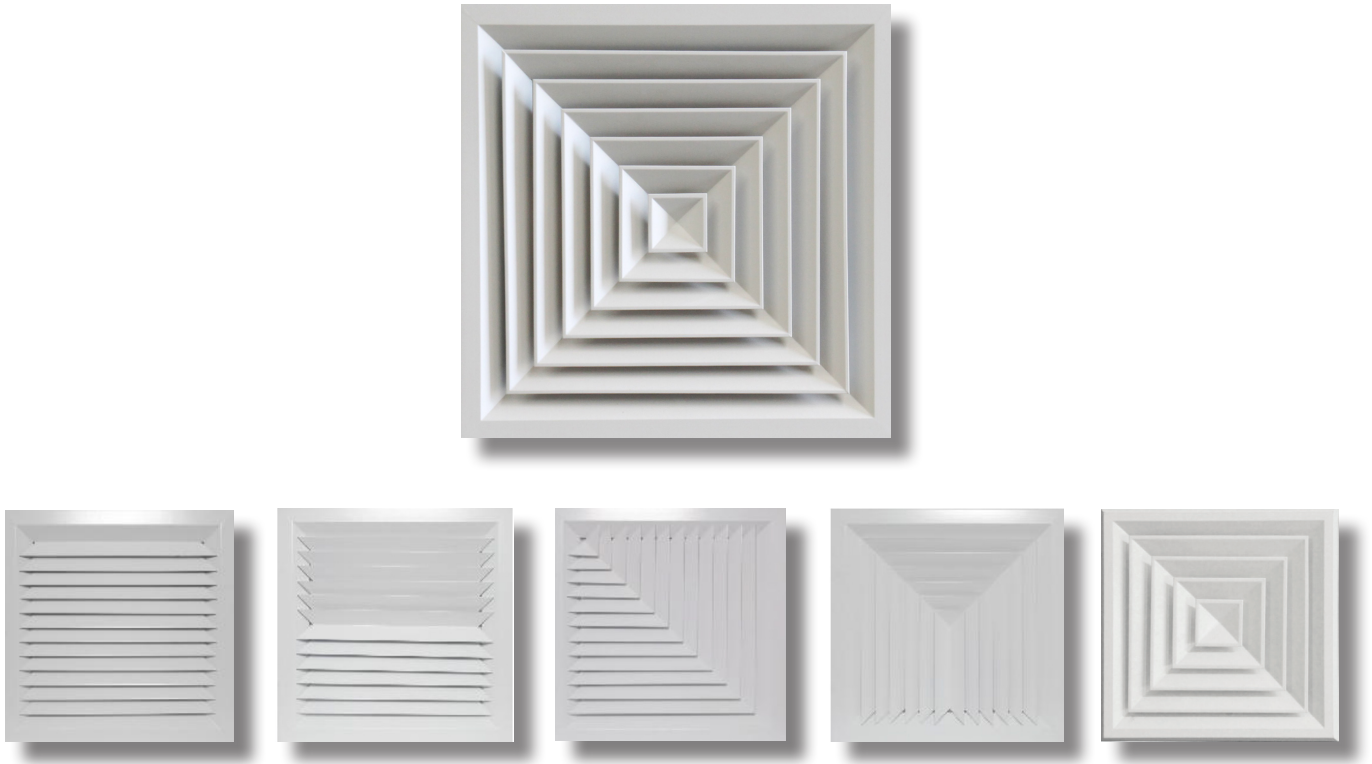

## Supply Square Diffuser

### General Information:

The special design of the range of square diffusers provides to any kind of space the requirements of decoration which today's architecture demands.

The broad range of products and possibilities to orientate the air flow in 1, 2, 3 or 4 ways, make them particularly indicated for spaces where a particular zone has to be treated, in geometrically irregular spaces or off-centre parts of the space (conjunction of wall and ceiling, etc.).

By means of laboratory tests it has been demonstrated that these are ideal for variable volume systems, due to its blade design, with which an adherent jet is obtained (Coanda effect) with a highly satisfactory efficiency, specially recommendable in cold air installations.

All square diffuser types have standardised neck dimensions for duct mounting according to ISO standard.

### Features:

- Supply or return air applications
- Complete assembly from extruded aluminium sections
- Rigid, heavy gauge extruded frames with reinforced mitered and welded corners
- Special patterns are available  
(Optional opposed blade damper)
- Powder coating finish, standard color white
- Size manufactured on request

## General notes on the quick selection table:

- These selection tables are based on full-scale laboratory tests
- The jet is adherent, i.e. the diffuser is mounted aligned with the ceiling.
- Room height is  $3 \pm 0.5\text{m}$
- Sound index NR is based on sound power, without room attenuation and without damper (mounting according to ISO).
- Throws given correspond to a maximum velocity ( $V_2$ ) of 0.25 m/s in the occupied zone.

### Throw correction factor for room width / length ratio.

This factor, called  $C_a$ , is given by the ratio of room width and length and is applicable to diffusers. And the value of  $C_a$  equals 1, since they have been tested in a square room ( $A/L=1$ )

Throw correction factor for distance of diffuser to ceiling ( $C_h$ )

For adherent jets, i.e. diffuser aligned with ceiling:  $C_h=1$

For free jets, with the diffuser separated from the ceiling:  $C_h=1.4$

The correct throw ( $X_c$ ) is obtained by:

$$X_c = X * C_a * C_h$$

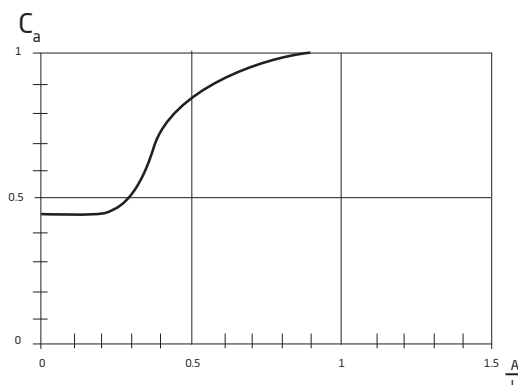
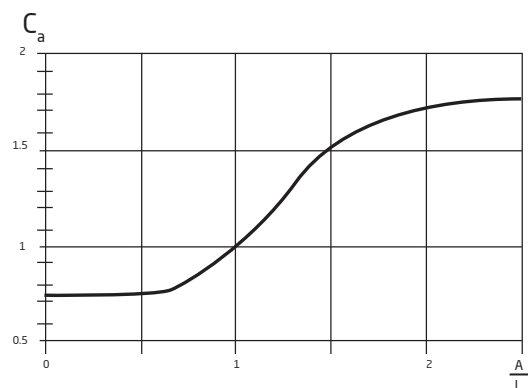
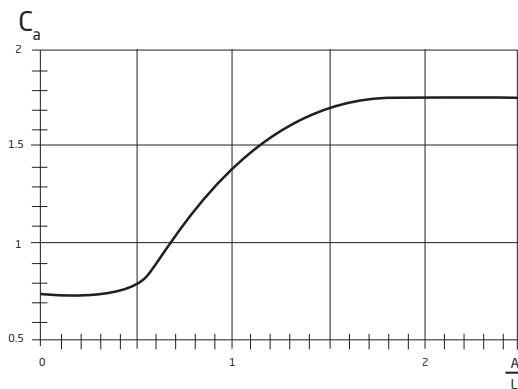

# Lay-In 1 Way Diffuser

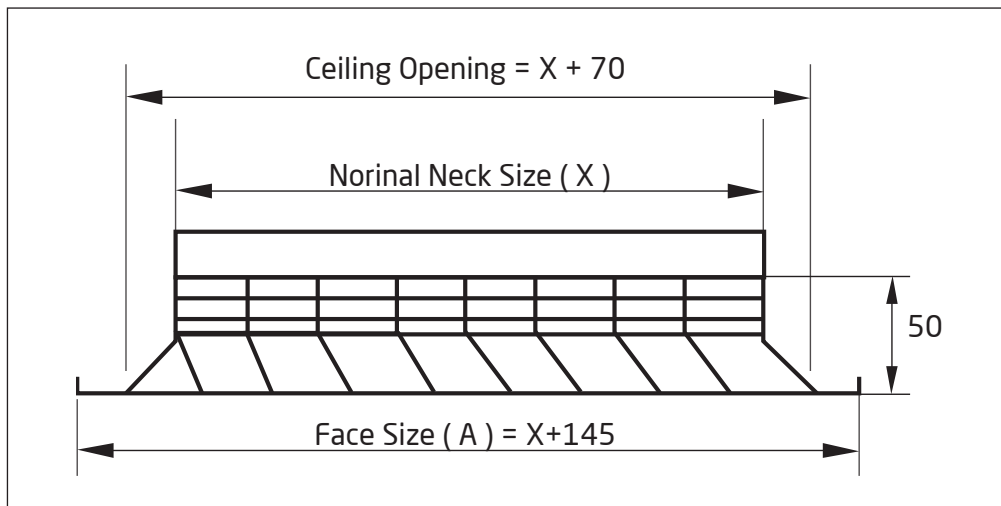

| Nominal Neck Metric ( X ) | Face Size ( A ) |
|---------------------------|-----------------|
| 150 x 150 mm              | 295 x 295 mm    |
| 225 x 225 mm              | 370 x 370 mm    |
| 300 x 300 mm              | 445 x 445 mm    |
| 375 x 375 mm              | 520 x 520 mm    |
| 450 x 450 mm              | 595 x 595 mm    |

\* Grilles are powder coated white as standard

\* The first number is for horizontal dimension and the second number is for vertical dimension

# Lay-In 2 Way Diffuser

## Lay- In 2 Way Opposite Diffuser

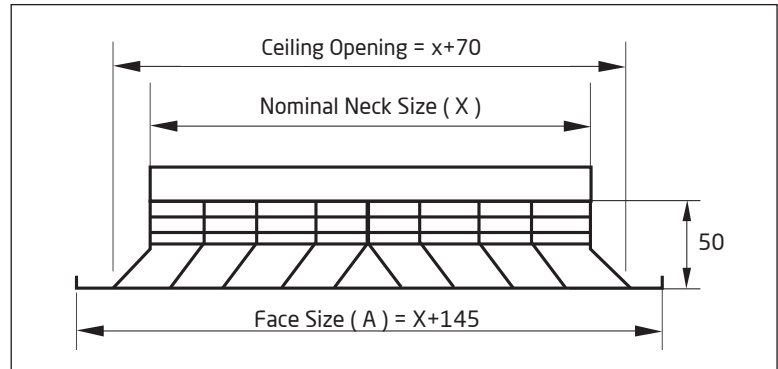

## Lay- In 2 Way Corner Diffuser

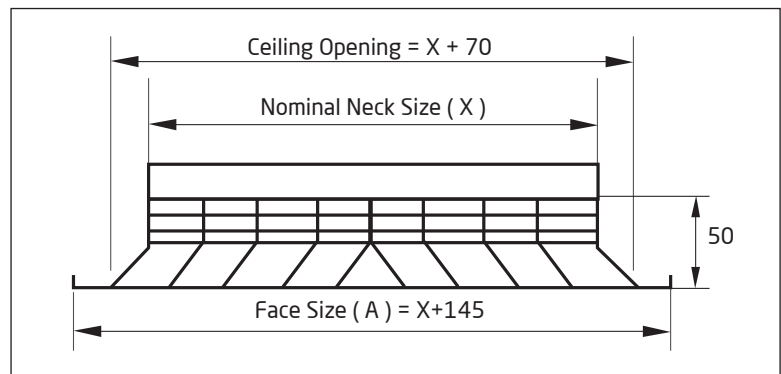

| Nominal Neck Metric ( X ) | Face Size ( A ) |
|---------------------------|-----------------|
| 150 x 150 mm              | 295 x 295 mm    |
| 225 x 225 mm              | 370 x 370 mm    |
| 300 x 300 mm              | 445 x 445 mm    |
| 375 x 375 mm              | 520 x 520 mm    |
| 450 x 450 mm              | 595 x 595 mm    |

\* Grilles are powder coated white as standard

\* The first number is for horizontal dimension and the second number is for vertical dimension

## Quick Selection Table

| Flow rate |       | Dim            | 150 x 150 | 225 x 225 | 300 x 300 | 375 x 375 | 450 x 450 | 525 x 525 | 600 x 600 |
|-----------|-------|----------------|-----------|-----------|-----------|-----------|-----------|-----------|-----------|
| (m³/h)    | (l/s) | A <sub>k</sub> | 0.0093    | 0.0209    | 0.0373    | 0.0582    | 0.0838    | 0.1141    | 0.1490    |
| 100       | 27.8  | V <sub>k</sub> | 3.0       | 1.3       |           |           |           |           |           |
|           |       | X              | 0.6       | 0.4       |           |           |           |           |           |
|           |       | P <sub>t</sub> | 6.7       | 1.3       |           |           |           |           |           |
|           |       | NR             | 22        | 5         |           |           |           |           |           |
| 120       | 33.3  | V <sub>k</sub> | 3.6       | 1.6       |           |           |           |           |           |
|           |       | X              | 0.7       | 0.5       |           |           |           |           |           |
|           |       | P <sub>t</sub> | 9.6       | 1.9       |           |           |           |           |           |
|           |       | NR             | 26        | 10        |           |           |           |           |           |
| 140       | 38.9  | V <sub>k</sub> | 4.2       | 1.9       | 1.0       |           |           |           |           |
|           |       | X              | 0.9       | 0.6       | 0.4       |           |           |           |           |
|           |       | P <sub>t</sub> | 13.1      | 2.6       | 0.8       |           |           |           |           |
|           |       | NR             | 30        | 14        | -         |           |           |           |           |
| 160       | 44.4  | V <sub>k</sub> | 4.8       | 2.1       | 1.2       |           |           |           |           |
|           |       | X              | 1.0       | 0.7       | 0.5       |           |           |           |           |
|           |       | P <sub>t</sub> | 17.1      | 3.4       | 1.1       |           |           |           |           |
|           |       | NR             | 33        | 17        | 5         |           |           |           |           |
| 180       | 50.0  | V <sub>k</sub> | 5.4       | 2.4       | 1.3       |           |           |           |           |
|           |       | X              | 1.1       | 0.7       | 0.5       |           |           |           |           |
|           |       | P <sub>t</sub> | 21.7      | 4.3       | 1.3       |           |           |           |           |
|           |       | NR             | 36        | 20        | 8         |           |           |           |           |
| 200       | 55.6  | V <sub>k</sub> | 6.0       | 2.7       | 1.5       | 1.0       |           |           |           |
|           |       | X              | 1.2       | 0.8       | 0.6       | 0.5       |           |           |           |
|           |       | P <sub>t</sub> | 26.8      | 5.3       | 1.7       | 0.7       |           |           |           |
|           |       | NR             | 39        | 22        | 11        | -         |           |           |           |
| 250       | 69.4  | V <sub>k</sub> | 7.5       | 3.3       | 1.9       | 1.2       |           |           |           |
|           |       | X              | 1.5       | 1.0       | 0.8       | 0.6       |           |           |           |
|           |       | P <sub>t</sub> | 41.8      | 8.3       | 2.6       | 1.1       |           |           |           |
|           |       | NR             | 44        | 28        | 16        | 7         |           |           |           |
| 300       | 83.3  | V <sub>k</sub> |           | 4.0       | 2.2       | 1.4       | 1.0       |           |           |
|           |       | X              |           | 1.2       | 0.9       | 0.7       | 0.6       |           |           |
|           |       | P <sub>t</sub> |           | 11.9      | 3.7       | 1.5       | 0.7       |           |           |
|           |       | NR             |           | 32        | 21        | 12        | -         |           |           |
| 350       | 97.2  | V <sub>k</sub> |           | 4.7       | 2.6       | 1.7       | 1.2       |           |           |
|           |       | X              |           | 1.4       | 1.1       | 0.9       | 0.7       |           |           |
|           |       | P <sub>t</sub> |           | 16.2      | 5.1       | 2.1       | 1.0       |           |           |
|           |       | NR             |           | 36        | 24        | 15        | 8         |           |           |
| 400       | 111.1 | V <sub>k</sub> |           | 5.3       | 3.0       | 1.9       | 1.3       | 1.0       |           |
|           |       | X              |           | 1.6       | 1.2       | 1.0       | 0.8       | 0.7       |           |
|           |       | P <sub>t</sub> |           | 21.2      | 6.7       | 2.7       | 1.3       | 0.7       |           |
|           |       | NR             |           | 40        | 28        | 19        | 11        | 5         |           |
| 450       | 125.0 | V <sub>k</sub> |           | 6.0       | 3.4       | 2.1       | 1.5       | 1.1       |           |
|           |       | X              |           | 1.8       | 1.4       | 1.1       | 0.9       | 0.8       |           |
|           |       | P <sub>t</sub> |           | 26.8      | 8.4       | 3.5       | 1.7       | 0.9       |           |
|           |       | NR             |           | 42        | 31        | 22        | 14        | 8         |           |
| 500       | 138.9 | V <sub>k</sub> |           | 6.6       | 3.7       | 2.4       | 1.7       | 1.2       | 0.9       |
|           |       | X              |           | 2.0       | 1.5       | 1.2       | 1.0       | 0.9       | 0.8       |
|           |       | P <sub>t</sub> |           | 33.1      | 10.4      | 4.3       | 2.1       | 1.1       | 0.7       |
|           |       | NR             |           | 45        | 33        | 24        | 17        | 10        | 5         |
| 600       | 166.7 | V <sub>k</sub> |           |           | 4.5       | 2.9       | 2.0       | 1.5       | 1.1       |
|           |       | X              |           |           | 1.8       | 1.5       | 1.2       | 1.0       | 0.9       |
|           |       | P <sub>t</sub> |           |           | 15        | 6.2       | 3.0       | 1.6       | 0.9       |
|           |       | NR             |           |           | 38        | 29        | 21        | 15        | 10        |

| Flow rate |        | Dim            | 150 x 150 | 225 x 225 | 300 x 300 | 375 x 375 | 450 x 450 | 525 x 525 | 600 x 600 |
|-----------|--------|----------------|-----------|-----------|-----------|-----------|-----------|-----------|-----------|
| (m³/h)    | (l/s)  | A <sub>k</sub> | 0.0093    | 0.0209    | 0.0373    | 0.0582    | 0.0838    | 0.1141    | 0.1490    |
| 700       | 194.4  | V <sub>k</sub> |           |           | 5.2       | 3.3       | 2.3       | 1.7       | 1.3       |
|           |        | X              |           |           | 2.1       | 1.7       | 1.4       | 1.2       | 1.1       |
|           |        | P <sub>t</sub> |           |           | 20.4      | 8.4       | 4.0       | 2.2       | 1.3       |
|           |        | NR             |           |           | 42        | 33        | 25        | 19        | 13        |
| 800       | 222.2  | V <sub>k</sub> |           |           | 6.0       | 3.8       | 2.7       | 1.9       | 1.5       |
|           |        | X              |           |           | 2.4       | 1.9       | 1.6       | 1.4       | 1.2       |
|           |        | P <sub>t</sub> |           |           | 26.6      | 10.9      | 5.3       | 2.8       | 1.7       |
|           |        | NR             |           |           | 45        | 36        | 28        | 22        | 17        |
| 900       | 250.0  | V <sub>k</sub> |           |           | 6.7       | 4.3       | 3.0       | 2.2       | 1.7       |
|           |        | X              |           |           | 2.7       | 2.2       | 1.8       | 1.6       | 1.4       |
|           |        | P <sub>t</sub> |           |           | 33.7      | 13.8      | 6.7       | 3.6       | 2.1       |
|           |        | NR             |           |           | 48        | 39        | 31        | 25        | 20        |
| 1000      | 277.8  | V <sub>k</sub> |           |           | 7.4       | 4.8       | 3.3       | 2.4       | 1.9       |
|           |        | X              |           |           | 3.0       | 2.4       | 2.0       | 1.7       | 1.5       |
|           |        | P <sub>t</sub> |           |           | 41.6      | 17.1      | 8.2       | 4.4       | 2.6       |
|           |        | NR             |           |           | 50        | 41        | 34        | 28        | 22        |
| 1200      | 333.3  | V <sub>k</sub> |           |           |           | 5.7       | 4.0       | 2.9       | 2.2       |
|           |        | X              |           |           |           | 2.9       | 2.4       | 2.1       | 1.8       |
|           |        | P <sub>t</sub> |           |           |           | 24.6      | 11.9      | 6.4       | 3.8       |
|           |        | NR             |           |           |           | 46        | 38        | 32        | 27        |
| 1400      | 388.9  | V <sub>k</sub> |           |           |           | 6.7       | 4.6       | 3.4       | 2.6       |
|           |        | X              |           |           |           | 3.4       | 2.8       | 2.4       | 2.1       |
|           |        | P <sub>t</sub> |           |           |           | 33.5      | 16.2      | 8.7       | 5.1       |
|           |        | NR             |           |           |           | 50        | 42        | 36        | 30        |
| 1600      | 444.4  | V <sub>k</sub> |           |           |           |           | 5.3       | 3.9       | 3.0       |
|           |        | X              |           |           |           |           | 3.2       | 2.8       | 2.4       |
|           |        | P <sub>t</sub> |           |           |           |           | 21.1      | 11.4      | 6.7       |
|           |        | NR             |           |           |           |           | 46        | 39        | 34        |
| 1800      | 500.0  | V <sub>k</sub> |           |           |           |           | 6.0       | 4.4       | 3.4       |
|           |        | X              |           |           |           |           | 3.7       | 3.1       | 2.7       |
|           |        | P <sub>t</sub> |           |           |           |           | 26.7      | 14.4      | 8.4       |
|           |        | NR             |           |           |           |           | 48        | 42        | 37        |
| 2000      | 555.6  | V <sub>k</sub> |           |           |           |           | 6.6       | 4.9       | 3.7       |
|           |        | X              |           |           |           |           | 4.1       | 3.5       | 3.0       |
|           |        | P <sub>t</sub> |           |           |           |           | 33.0      | 17.8      | 10.4      |
|           |        | NR             |           |           |           |           | 51        | 45        | 39        |
| 2500      | 694.4  | V <sub>k</sub> |           |           |           |           |           | 6.1       | 4.7       |
|           |        | X              |           |           |           |           |           | 4.4       | 3.8       |
|           |        | P <sub>t</sub> |           |           |           |           |           | 27.8      | 16.3      |
|           |        | NR             |           |           |           |           |           | 50        | 45        |
| 3000      | 833.3  | V <sub>k</sub> |           |           |           |           |           | 7.3       | 5.6       |
|           |        | X              |           |           |           |           |           | 5.2       | 4.6       |
|           |        | P <sub>t</sub> |           |           |           |           |           | 40.0      | 23.5      |
|           |        | NR             |           |           |           |           |           | 55        | 49        |
| 3500      | 972.2  | V <sub>k</sub> |           |           |           |           |           |           | 6.5       |
|           |        | X              |           |           |           |           |           |           | 5.3       |
|           |        | P <sub>t</sub> |           |           |           |           |           |           | 31.9      |
|           |        | NR             |           |           |           |           |           |           | 53        |
| 4000      | 1111.1 | V <sub>k</sub> |           |           |           |           |           |           | 7.5       |
|           |        | X              |           |           |           |           |           |           | 6.1       |
|           |        | P <sub>t</sub> |           |           |           |           |           |           | 41.7      |
|           |        | NR             |           |           |           |           |           |           | 56        |

**Symbols:**

A<sub>k</sub> - Effective area

V<sub>k</sub> - Effective velocity in m/s

X - Throw in metres correspond to a terminal velocity in occupied zone of 0.25m/s

Pressure (P<sub>t</sub>) - All pressures are in Pa (N/m²)

NR - Noise level index in dB based on a room absorption and one diffuser

# Lay-In 3 Way Diffuser

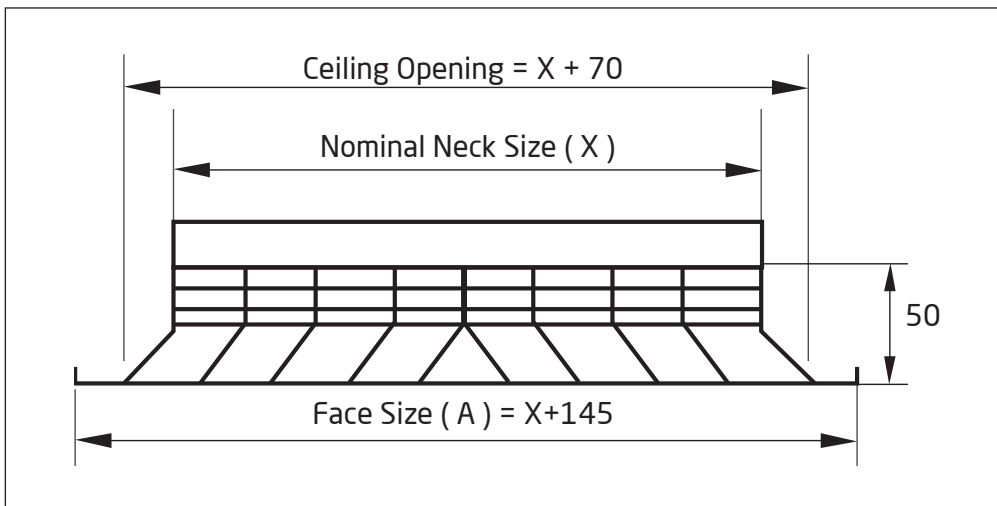

| Nominal Neck Metric ( X ) | Face Size ( A ) |
|---------------------------|-----------------|
| 150 x 150 mm              | 295 x 295 mm    |
| 225 x 225 mm              | 370 x 370 mm    |
| 300 x 300 mm              | 445 x 445 mm    |
| 375 x 375 mm              | 520 x 520 mm    |
| 450 x 450 mm              | 595 x 595 mm    |

\* Grilles are powder coated white as standard

\* The first number is for horizontal dimension and the second number is for vertical dimension

## Quick Selection Table

| Flow rate |       | Dim            | 150 x 150 | 225 x 225 | 29300 x 300 | 375 x 375 | 450 x 450 |
|-----------|-------|----------------|-----------|-----------|-------------|-----------|-----------|
| (m³/h)    | (l/s) | A <sub>k</sub> | 0.0089    | 0.0200    | 0.0355      | 0.0554    | 0.0798    |
| 100       | 27.8  | V <sub>k</sub> | 3.1       |           |             |           |           |
|           |       | X              | 0.6       |           |             |           |           |
|           |       | P <sub>t</sub> | 8.5       |           |             |           |           |
|           |       | NR             | 17        |           |             |           |           |
| 120       | 33.3  | V <sub>k</sub> | 3.7       |           |             |           |           |
|           |       | X              | 0.7       |           |             |           |           |
|           |       | P <sub>t</sub> | 12.2      |           |             |           |           |
|           |       | NR             | 22        |           |             |           |           |
| 140       | 38.9  | V <sub>k</sub> | 4.4       | 1.9       |             |           |           |
|           |       | X              | 0.8       | 0.6       |             |           |           |
|           |       | P <sub>t</sub> | 16.6      | 3.3       |             |           |           |
|           |       | NR             | 25        | 9         |             |           |           |
| 160       | 44.4  | V <sub>k</sub> | 5.0       | 2.2       |             |           |           |
|           |       | X              | 1.0       | 0.6       |             |           |           |
|           |       | P <sub>t</sub> | 21.7      | 4.3       |             |           |           |
|           |       | NR             | 29        | 12        |             |           |           |
| 180       | 50.0  | V <sub>k</sub> | 5.6       | 2.5       |             |           |           |
|           |       | X              | 1.1       | 0.7       |             |           |           |
|           |       | P <sub>t</sub> | 27.5      | 5.4       |             |           |           |
|           |       | NR             | 32        | 15        |             |           |           |
| 200       | 55.6  | V <sub>k</sub> | 6.2       | 2.8       | 1.6         |           |           |
|           |       | X              | 1.2       | 0.8       | 0.6         |           |           |
|           |       | P <sub>t</sub> | 33.9      | 6.7       | 2.1         |           |           |
|           |       | NR             | 34        | 18        | 6           |           |           |
| 250       | 69.4  | V <sub>k</sub> | 7.8       | 3.5       | 2.0         |           |           |
|           |       | X              | 1.5       | 1.0       | 0.8         |           |           |
|           |       | P <sub>t</sub> | 53.0      | 10.5      | 3.3         |           |           |
|           |       | NR             | 40        | 23        | 12          |           |           |
| 300       | 83.3  | V <sub>k</sub> | 9.4       | 4.2       | 2.3         | 1.5       |           |
|           |       | X              | 1.8       | 1.2       | 0.9         | 0.7       |           |
|           |       | P <sub>t</sub> | 76.3      | 15.1      | 4.8         | 2.0       |           |
|           |       | NR             | 44        | 28        | 16          | 7         |           |
| 350       | 97.2  | V <sub>k</sub> |           | 4.9       | 2.7         | 1.8       |           |
|           |       | X              |           | 1.4       | 1.1         | 0.8       |           |
|           |       | P <sub>t</sub> |           | 20.6      | 6.5         | 2.7       |           |
|           |       | NR             |           | 32        | 20          | 11        |           |
| 400       | 111.1 | V <sub>k</sub> |           | 5.6       | 3.1         | 2.0       |           |
|           |       | X              |           | 1.6       | 1.2         | 1.0       |           |
|           |       | P <sub>t</sub> |           | 26.9      | 8.5         | 3.5       |           |
|           |       | NR             |           | 35        | 23          | 14        |           |
| 450       | 125.0 | V <sub>k</sub> |           | 6.3       | 3.5         | 2.3       | 1.6       |
|           |       | X              |           | 1.8       | 1.4         | 1.1       | 0.9       |
|           |       | P <sub>t</sub> |           | 34.0      | 10.8        | 4.4       | 2.1       |
|           |       | NR             |           | 38        | 26          | 17        | 10        |
| 500       | 138.9 | V <sub>k</sub> |           | 6.9       | 3.9         | 2.5       | 1.7       |
|           |       | X              |           | 2.0       | 1.5         | 1.2       | 1.0       |
|           |       | P <sub>t</sub> |           | 42.0      | 13.3        | 5.5       | 2.6       |
|           |       | NR             |           | 40        | 29          | 20        | 12        |

| Flow rate |       | Dim            | 150 x 150 | 225 x 225 | 300 x 300 | 375 x 375 | 450 x 450 |
|-----------|-------|----------------|-----------|-----------|-----------|-----------|-----------|
| (m³/h)    | (l/s) | A <sub>k</sub> | 0.0089    | 0.0200    | 0.0355    | 0.0554    | 0.0798    |
| 600       | 166.7 | V <sub>k</sub> |           |           | 4.7       | 3.0       | 2.1       |
|           |       | X              |           |           | 1.8       | 1.4       | 1.2       |
|           |       | P <sub>t</sub> |           |           | 19.2      | 7.9       | 3.8       |
|           |       | NR             |           |           | 33        | 24        | 17        |
| 700       | 194.4 | V <sub>k</sub> |           |           | 5.5       | 3.5       | 2.4       |
|           |       | X              |           |           | 2.1       | 1.7       | 1.4       |
|           |       | P <sub>t</sub> |           |           | 26.1      | 10.7      | 5.2       |
|           |       | NR             |           |           | 37        | 28        | 21        |
| 800       | 222.2 | V <sub>k</sub> |           |           | 6.3       | 4.0       | 2.8       |
|           |       | X              |           |           | 2.4       | 1.9       | 1.6       |
|           |       | P <sub>t</sub> |           |           | 34.1      | 14.0      | 6.7       |
|           |       | NR             |           |           | 40        | 31        | 24        |
| 900       | 250.0 | V <sub>k</sub> |           |           | 7.0       | 4.5       | 3.1       |
|           |       | X              |           |           | 2.7       | 2.2       | 1.8       |
|           |       | P <sub>t</sub> |           |           | 43.1      | 17.7      | 8.5       |
|           |       | NR             |           |           | 43        | 34        | 27        |
| 1000      | 277.8 | V <sub>k</sub> |           |           | 7.8       | 5.0       | 3.5       |
|           |       | X              |           |           | 3.0       | 2.4       | 2.0       |
|           |       | P <sub>t</sub> |           |           | 53.3      | 21.9      | 10.5      |
|           |       | NR             |           |           | 46        | 37        | 29        |
| 1200      | 333.3 | V <sub>k</sub> |           |           |           | 6.0       | 4.2       |
|           |       | X              |           |           |           | 2.9       | 2.4       |
|           |       | P <sub>t</sub> |           |           |           | 31.5      | 15.2      |
|           |       | NR             |           |           |           | 41        | 34        |
| 1400      | 388.9 | V <sub>k</sub> |           |           |           | 7.0       | 4.9       |
|           |       | X              |           |           |           | 3.4       | 2.8       |
|           |       | P <sub>t</sub> |           |           |           | 42.9      | 20.7      |
|           |       | NR             |           |           |           | 45        | 38        |
| 1600      | 444.4 | V <sub>k</sub> |           |           |           | 8.0       | 5.6       |
|           |       | X              |           |           |           | 3.9       | 3.2       |
|           |       | P <sub>t</sub> |           |           |           | 56.0      | 27.0      |
|           |       | NR             |           |           |           | 48        | 41        |
| 1800      | 500.0 | V <sub>k</sub> |           |           |           |           | 6.3       |
|           |       | X              |           |           |           |           | 3.6       |
|           |       | P <sub>t</sub> |           |           |           |           | 34.2      |
|           |       | NR             |           |           |           |           | 44        |
| 2000      | 555.6 | V <sub>k</sub> |           |           |           |           | 7.0       |
|           |       | X              |           |           |           |           | 4.0       |
|           |       | P <sub>t</sub> |           |           |           |           | 42.2      |
|           |       | NR             |           |           |           |           | 47        |
| 2500      | 694.4 | V <sub>k</sub> |           |           |           |           | 8.7       |
|           |       | X              |           |           |           |           | 5.0       |
|           |       | P <sub>t</sub> |           |           |           |           | 65.9      |
|           |       | NR             |           |           |           |           | 52        |
| 3000      | 833.3 | V <sub>k</sub> |           |           |           |           | 10.4      |
|           |       | X              |           |           |           |           | 6.0       |
|           |       | P <sub>t</sub> |           |           |           |           | 94.9      |
|           |       | NR             |           |           |           |           | 57        |

Symbols:

A<sub>k</sub> - Effective area

V<sub>k</sub> - Effective velocity in m/s

X - Throw in metres correspond to a terminal velocity in occupied zone of 0.25m/s

Pressure (P<sub>t</sub>) - All pressures are in Pa (N/m²)

NR - Noise level index in dB based on a room absorption and one diffuser

# Lay-In 4 Way Diffuser

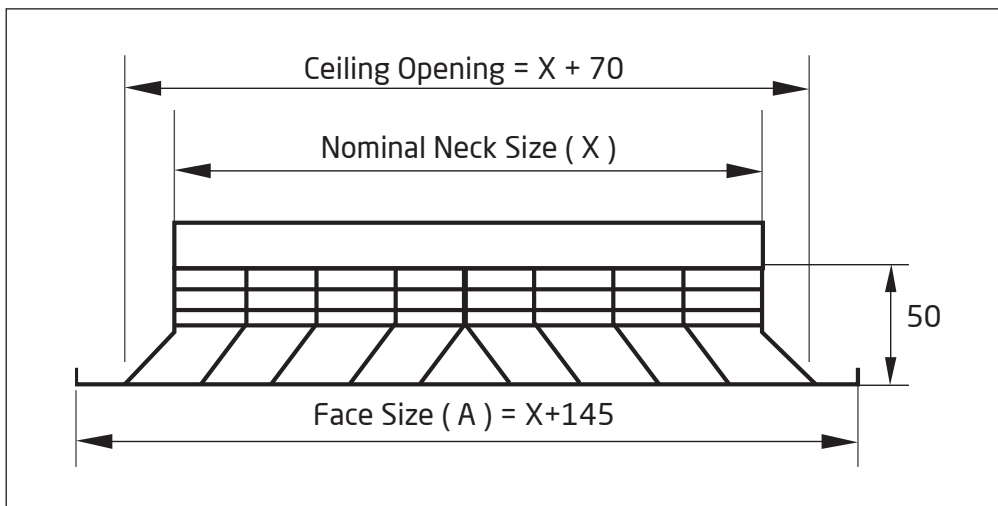

| Nominal Neck Metric ( X ) | Face Size ( A ) |
|---------------------------|-----------------|
| 150 x 150 mm              | 295 x 295 mm    |
| 225 x 225 mm              | 370 x 370 mm    |
| 300 x 300 mm              | 445 x 445 mm    |
| 375 x 375 mm              | 520 x 520 mm    |
| 450 x 450 mm              | 595 x 595 mm    |

\* Grilles are powder coated white as standard

\* The first number is for horizontal dimension and the second number is for vertical dimension

## Quick Selection Table

| Flow rate           |       | Dim            | 150 x 150 | 225 x 225 | 300 x 300 | 375 x 375 | 450 x 450 | 525 x 525 | 600 x 600 | Flow rate           |       | Dim            | 150 x 150 | 225 x 225      | 300 x 300 | 375 x 375 | 450 x 450 | 525 x 525 | 600 x 600 |     |     |  |
|---------------------|-------|----------------|-----------|-----------|-----------|-----------|-----------|-----------|-----------|---------------------|-------|----------------|-----------|----------------|-----------|-----------|-----------|-----------|-----------|-----|-----|--|
| (m <sup>3</sup> /h) | (l/s) | A <sub>e</sub> | 0.0096    | 0.0215    | 0.0383    | 0.0598    | 0.0863    | 0.1174    | 0.1534    | (m <sup>3</sup> /h) | (l/s) | A <sub>e</sub> | 0.0096    | 0.0215         | 0.0383    | 0.0598    | 0.0863    | 0.1174    | 0.1534    |     |     |  |
| 50                  | 13.9  | V <sub>k</sub> | 1.4       |           |           |           |           |           |           | 350                 | 97.2  | V <sub>k</sub> |           | 4.5            | 2.5       | 1.6       | 1.1       | 0.8       |           |     |     |  |
|                     |       | X              | 0.9       |           |           |           |           |           |           |                     |       |                | X         |                | 4.1       | 3.1       | 2.5       | 2.0       | 1.8       |     |     |  |
|                     |       | P <sub>t</sub> | 1.5       |           |           |           |           |           |           |                     |       |                |           | P <sub>t</sub> |           | 14.3      | 4.5       | 1.9       | 0.9       | 0.5 |     |  |
|                     |       | NR             | -         |           |           |           |           |           |           |                     |       |                |           | NR             |           | 36        | 24        | 15        | 7         | -   |     |  |
| 60                  | 16.7  | V <sub>k</sub> | 1.7       |           |           |           |           |           |           | 400                 | 111.1 | V <sub>k</sub> |           | 5.2            | 2.9       | 1.9       | 1.3       | 0.9       |           |     |     |  |
|                     |       | X              | 1.1       |           |           |           |           |           |           |                     |       |                | X         |                | 4.7       | 3.5       | 2.8       | 2.3       | 2.0       |     |     |  |
|                     |       | P <sub>t</sub> | 2.1       |           |           |           |           |           |           |                     |       |                |           | P <sub>t</sub> |           | 18.7      | 5.9       | 2.4       | 1.2       | 0.6 |     |  |
|                     |       | NR             | 9         |           |           |           |           |           |           |                     |       |                |           | NR             |           | 39        | 27        | 18        | 10        | -   |     |  |
| 70                  | 19.4  | V <sub>k</sub> | 2.0       | 0.9       |           |           |           |           |           | 500                 | 138.9 | V <sub>k</sub> |           | 6.5            | 3.6       | 2.3       | 1.6       | 1.2       | 0.9       |     |     |  |
|                     |       | X              | 1.2       | 0.8       |           |           |           |           |           |                     |       |                | X         |                | 5.8       | 4.4       | 3.5       | 2.9       | 2.5       | 2.2 |     |  |
|                     |       | P <sub>t</sub> | 2.9       | 0.6       |           |           |           |           |           |                     |       |                |           | P <sub>t</sub> |           | 29.2      | 9.2       | 3.8       | 1.8       | 1.0 | 0.6 |  |
|                     |       | NR             | 13        | -         |           |           |           |           |           |                     |       |                |           | NR             |           | 45        | 33        | 23        | 16        | 9   | -   |  |
| 80                  | 22.2  | V <sub>k</sub> | 2.3       | 1.0       |           |           |           |           |           | 600                 | 166.7 | V <sub>k</sub> |           |                | 4.4       | 2.8       | 1.9       | 1.4       | 1.1       |     |     |  |
|                     |       | X              | 1.4       | 0.9       |           |           |           |           |           |                     |       |                | X         |                |           | 5.3       | 4.2       | 3.5       | 3.0       | 2.6 |     |  |
|                     |       | P <sub>t</sub> | 3.8       | 0.7       |           |           |           |           |           |                     |       |                |           | P <sub>t</sub> |           |           | 13.3      | 5.4       | 2.6       | 1.4 | 0.8 |  |
|                     |       | NR             | 16        | -         |           |           |           |           |           |                     |       |                |           | NR             |           |           | 37        | 28        | 20        | 14  | 8   |  |
| 90                  | 25.0  | V <sub>k</sub> | 2.6       | 1.2       |           |           |           |           |           | 700                 | 194.4 | V <sub>k</sub> |           |                | 5.1       | 3.3       | 2.3       | 1.7       | 1.3       |     |     |  |
|                     |       | X              | 1.6       | 1.1       |           |           |           |           |           |                     |       |                | X         |                |           | 6.1       | 4.9       | 4.1       | 3.5       | 3.1 |     |  |
|                     |       | P <sub>t</sub> | 4.7       | 0.9       |           |           |           |           |           |                     |       |                |           | P <sub>t</sub> |           |           | 18.0      | 7.4       | 3.6       | 1.9 | 1.1 |  |
|                     |       | NR             | 19        | -         |           |           |           |           |           |                     |       |                |           | NR             |           |           | 41        | 32        | 24        | 18  | 12  |  |
| 100                 | 27.8  | V <sub>k</sub> | 2.9       | 1.3       |           |           |           |           |           | 800                 | 222.2 | V <sub>k</sub> |           |                | 5.8       | 3.7       | 2.6       | 1.9       | 1.4       |     |     |  |
|                     |       | X              | 1.8       | 1.2       |           |           |           |           |           |                     |       |                | X         |                |           | 7.0       | 5.6       | 4.7       | 4.0       | 3.5 |     |  |
|                     |       | P <sub>t</sub> | 5.9       | 1.2       |           |           |           |           |           |                     |       |                |           | P <sub>t</sub> |           |           | 23.6      | 9.7       | 4.6       | 2.5 | 1.5 |  |
|                     |       | NR             | 22        | 5         |           |           |           |           |           |                     |       |                |           | NR             |           |           | 44        | 35        | 27        | 21  | 15  |  |
| 120                 | 33.3  | V <sub>k</sub> | 3.5       | 1.6       | 0.9       |           |           |           |           | 900                 | 250.0 | V <sub>k</sub> |           |                | 6.5       | 4.2       | 2.9       | 2.1       | 1.6       |     |     |  |
|                     |       | X              | 2.1       | 1.4       | 1.1       |           |           |           |           |                     |       |                | X         |                |           | 7.9       | 6.3       | 5.3       | 4.5       | 3.9 |     |  |
|                     |       | P <sub>t</sub> | 8.4       | 1.7       | 0.5       |           |           |           |           |                     |       |                |           | P <sub>t</sub> |           |           | 29.8      | 12.2      | 5.9       | 3.2 | 1.9 |  |
|                     |       | NR             | 26        | 9         | -         |           |           |           |           |                     |       |                |           | NR             |           |           | 47        | 38        | 30        | 24  | 18  |  |
| 140                 | 38.9  | V <sub>k</sub> | 4.1       | 1.8       | 1.0       |           |           |           |           | 1000                | 277.8 | V <sub>k</sub> |           |                | 4.6       | 3.2       | 2.4       | 1.8       |           |     |     |  |
|                     |       | X              | 2.5       | 1.6       | 1.2       |           |           |           |           |                     |       |                | X         |                |           | 7.0       | 5.8       | 5.0       | 4.4       |     |     |  |
|                     |       | P <sub>t</sub> | 11.5      | 2.3       | 0.7       |           |           |           |           |                     |       |                |           | P <sub>t</sub> |           |           | 15.1      | 7.3       | 3.9       | 2.3 |     |  |
|                     |       | NR             | 30        | 13        | -         |           |           |           |           |                     |       |                |           | NR             |           |           | 41        | 33        | 26        | 21  |     |  |
| 160                 | 44.4  | V <sub>k</sub> | 4.6       | 2.1       | 1.2       |           |           |           |           | 1200                | 333.3 | V <sub>k</sub> |           |                | 5.6       | 3.9       | 2.8       | 2.2       |           |     |     |  |
|                     |       | X              | 2.8       | 1.9       | 1.4       |           |           |           |           |                     |       |                | X         |                |           | 8.4       | 7.0       | 6.0       | 5.3       |     |     |  |
|                     |       | P <sub>t</sub> | 15.0      | 3.0       | 0.9       |           |           |           |           |                     |       |                |           | P <sub>t</sub> |           |           | 21.7      | 10.4      | 5.6       | 3.3 |     |  |
|                     |       | NR             | 33        | 16        | -         |           |           |           |           |                     |       |                |           | NR             |           |           | 45        | 37        | 31        | 25  |     |  |
| 180                 | 50.0  | V <sub>k</sub> | 5.2       | 2.3       | 1.3       |           |           |           |           | 1400                | 388.9 | V <sub>k</sub> |           |                | 6.5       | 4.5       | 3.3       | 2.5       |           |     |     |  |
|                     |       | X              | 3.2       | 2.1       | 1.6       |           |           |           |           |                     |       |                | X         |                |           | 9.8       | 8.2       | 7.0       | 6.1       |     |     |  |
|                     |       | P <sub>t</sub> | 19.0      | 3.8       | 1.2       |           |           |           |           |                     |       |                |           | P <sub>t</sub> |           |           | 29.6      | 14.2      | 7.7       | 4.5 |     |  |
|                     |       | NR             | 36        | 19        | 7         |           |           |           |           |                     |       |                |           | NR             |           |           | 49        | 41        | 35        | 29  |     |  |
| 200                 | 55.6  | V <sub>k</sub> | 5.8       | 2.6       | 1.5       | 0.9       |           |           |           | 1600                | 444.4 | V <sub>k</sub> |           |                | 5.1       | 3.8       | 2.9       |           |           |     |     |  |
|                     |       | X              | 3.5       | 2.3       | 1.8       | 1.4       |           |           |           |                     |       |                | X         |                |           | 9.3       | 8.0       | 7.0       |           |     |     |  |
|                     |       | P <sub>t</sub> | 23.4      | 4.7       | 1.5       | 0.6       |           |           |           |                     |       |                |           | P <sub>t</sub> |           |           | 18.6      | 10.0      | 5.9       |     |     |  |
|                     |       | NR             | 39        | 22        | 10        | -         |           |           |           |                     |       |                |           | NR             |           |           | 44        | 38        | 33        |     |     |  |
| 250                 | 69.4  | V <sub>k</sub> | 7.2       | 3.2       | 1.8       | 1.2       | 0.8       |           |           | 1800                | 500.0 | V <sub>k</sub> |           |                | 5.8       | 4.3       | 3.3       |           |           |     |     |  |
|                     |       | X              | 4.4       | 2.9       | 2.2       | 1.8       | 1.5       |           |           |                     |       |                | X         |                |           | 10.5      | 9.0       | 7.9       |           |     |     |  |
|                     |       | P <sub>t</sub> | 36.6      | 7.3       | 2.3       | 0.9       | 0.5       |           |           |                     |       |                |           | P <sub>t</sub> |           |           | 23.5      | 12.7      | 7.4       |     |     |  |
|                     |       | NR             | 44        | 28        | 15        | 6         | -         |           |           |                     |       |                |           | NR             |           |           | 47        | 41        | 35        |     |     |  |
| 300                 | 83.3  | V <sub>k</sub> |           | 3.9       | 2.2       | 1.4       | 1.0       |           |           | 2000                | 555.6 | V <sub>k</sub> |           |                | 6.4       | 4.7       | 3.6       |           |           |     |     |  |
|                     |       | X              |           | 3.5       | 2.6       | 2.1       | 1.8       |           |           |                     |       |                | X         |                |           | 11.7      | 10.0      | 8.8       |           |     |     |  |
|                     |       | P <sub>t</sub> |           | 10.5      | 3.3       | 1.4       | 0.7       |           |           |                     |       |                |           | P <sub>t</sub> |           |           | 29.0      | 15.7      | 9.2       |     |     |  |
|                     |       | NR             |           | 32        | 20        | 11        | -         |           |           |                     |       |                |           | NR             |           |           | 50        | 44        | 38        |     |     |  |

**Symbols:**

A<sub>k</sub> - Effective area

V<sub>k</sub> - Effective velocity in m/s

X - Throw in metres correspond to a terminal velocity in occupied zone of 0.25m/s

Pressure (P<sub>t</sub>) - All pressures are in Pa (N/m<sup>2</sup>)

NR - Noise level index in dB based on a room absorption and one diffuser

## Quick Selection Table

| Flow rate |       | Dim            | 150 x 150 | 225 x 225 | 300 x 300 | 375 x 375 | 450 x 450 | 525 x 525 | 600 x 160 | Flow rate |        | Dim            | 150 x 150      | 225 x 225 | 300 x 300 | 375 x 375 | 450 x 450 | 525 x 525 | 600 x 160 |      |      |
|-----------|-------|----------------|-----------|-----------|-----------|-----------|-----------|-----------|-----------|-----------|--------|----------------|----------------|-----------|-----------|-----------|-----------|-----------|-----------|------|------|
| (m³/h)    | (l/s) | A <sub>k</sub> | 0.0109    | 0.0244    | 0.0435    | 0.0679    | 0.0978    | 0.1331    | 0.1739    | (m³/h)    | (l/s)  | A <sub>k</sub> | 0.0109         | 0.0244    | 0.0435    | 0.0679    | 0.0978    | 0.1331    | 0.1739    |      |      |
| 100       | 27.8  | V <sub>k</sub> | 2.5       | 1.1       |           |           |           |           |           | 700       | 194.4  | V <sub>k</sub> |                | 8.0       | 4.5       | 2.9       | 2.0       | 1.5       | 1.1       |      |      |
|           |       | X              | 0.5       | 0.3       |           |           |           |           |           |           |        | X              |                | 2.3       | 1.7       | 1.4       | 1.2       | 1.0       | 0.9       |      |      |
|           |       | P <sub>t</sub> | 4.5       | 0.9       |           |           |           |           |           |           |        |                | P <sub>t</sub> |           | 44.5      | 14.0      | 5.7       | 2.8       | 1.5       | 0.9  |      |
|           |       | NR             | 18        | -         |           |           |           |           |           |           |        |                | NR             |           | 49        | 37        | 28        | 21        | 15        | 9    |      |
| 120       | 33.3  | V <sub>k</sub> | 3.1       | 1.4       |           |           |           |           |           | 800       | 222.2  | V <sub>k</sub> |                |           | 5.1       | 3.3       | 2.3       | 1.7       | 1.3       |      |      |
|           |       | X              | 0.6       | 0.4       |           |           |           |           |           |           |        | X              |                |           | 2.0       | 1.6       | 1.3       | 1.1       | 1.0       |      |      |
|           |       | P <sub>t</sub> | 6.5       | 1.3       |           |           |           |           |           |           |        |                | P <sub>t</sub> |           |           | 18.3      | 7.5       | 3.6       | 2.0       | 1.1  |      |
|           |       | NR             | 22        | 6         |           |           |           |           |           |           |        |                | NR             |           |           | 41        | 32        | 24        | 18        | 12   |      |
| 140       | 38.9  | V <sub>k</sub> | 3.6       | 1.6       |           |           |           |           |           | 900       | 250.0  | V <sub>k</sub> |                |           | 5.7       | 3.7       | 2.6       | 1.9       | 1.4       |      |      |
|           |       | X              | 0.7       | 0.5       |           |           |           |           |           |           |        | X              |                |           | 2.2       | 1.8       | 1.5       | 1.3       | 1.1       |      |      |
|           |       | P <sub>t</sub> | 8.9       | 1.8       |           |           |           |           |           |           |        |                | P <sub>t</sub> |           |           | 23.1      | 9.5       | 4.6       | 2.5       | 1.4  |      |
|           |       | NR             | 26        | 9         |           |           |           |           |           |           |        |                | NR             |           |           | 44        | 35        | 27        | 21        | 15   |      |
| 160       | 44.4  | V <sub>k</sub> | 4.1       | 1.8       | 1.0       |           |           |           |           | 1000      | 277.8  | V <sub>k</sub> |                |           | 6.4       | 4.1       | 2.8       | 2.1       | 1.6       |      |      |
|           |       | X              | 0.8       | 0.5       | 0.4       |           |           |           |           |           |        | X              |                |           | 2.5       | 2.0       | 1.7       | 1.4       | 1.2       |      |      |
|           |       | P <sub>t</sub> | 11.6      | 2.3       | 0.7       |           |           |           |           |           |        |                | P <sub>t</sub> |           |           | 28.5      | 11.7      | 5.6       | 3.0       | 1.8  |      |
|           |       | NR             | 29        | 13        | -         |           |           |           |           |           |        |                | NR             |           |           | 46        | 37        | 30        | 23        | 18   |      |
| 180       | 50.0  | V <sub>k</sub> | 4.6       | 2.0       | 1.1       |           |           |           |           | 1200      | 333.3  | V <sub>k</sub> |                |           | 7.7       | 4.9       | 3.4       | 2.5       | 1.9       |      |      |
|           |       | X              | 0.9       | 0.6       | 0.4       |           |           |           |           |           |        | X              |                |           | 3.0       | 2.4       | 2.0       | 1.7       | 1.5       |      |      |
|           |       | P <sub>t</sub> | 14.7      | 2.9       | 0.9       |           |           |           |           |           |        |                | P <sub>t</sub> |           |           | 41.1      | 16.9      | 8.1       | 4.4       | 2.6  |      |
|           |       | NR             | 32        | 16        | -         |           |           |           |           |           |        |                | NR             |           |           | 51        | 42        | 34        | 28        | 23   |      |
| 200       | 55.6  | V <sub>k</sub> | 5.1       | 2.3       | 1.3       |           |           |           |           | 1400      | 388.9  | V <sub>k</sub> |                |           |           | 5.7       | 4.0       | 2.9       | 2.2       |      |      |
|           |       | X              | 1.0       | 0.7       | 0.5       |           |           |           |           |           |        | X              |                |           |           | 2.8       | 2.3       | 2.0       | 1.7       |      |      |
|           |       | P <sub>t</sub> | 18.2      | 3.6       | 1.1       |           |           |           |           |           |        |                | P <sub>t</sub> |           |           |           | 23        | 11.1      | 6.0       | 3.5  |      |
|           |       | NR             | 35        | 18        | 6         |           |           |           |           |           |        |                | NR             |           |           |           | 46        | 38        | 32        | 26   |      |
| 250       | 69.4  | V <sub>k</sub> | 6.4       | 2.8       | 1.6       | 1.0       |           |           |           | 1600      | 444.4  | V <sub>k</sub> |                |           |           | 6.5       | 4.5       | 3.3       | 2.6       |      |      |
|           |       | X              | 1.2       | 0.8       | 0.6       | 0.5       |           |           |           |           |        | X              |                |           |           | 3.2       | 2.7       | 2.3       | 2.0       |      |      |
|           |       | P <sub>t</sub> | 28.4      | 5.7       | 1.8       | 0.7       |           |           |           |           |        |                | P <sub>t</sub> |           |           |           | 30        | 14.5      | 7.8       | 4.6  |      |
|           |       | NR             | 40        | 24        | 12        | -         |           |           |           |           |        |                | NR             |           |           |           | 49        | 41        | 35        | 30   |      |
| 300       | 83.3  | V <sub>k</sub> | 7.6       | 3.4       | 1.9       | 1.2       |           |           |           | 1800      | 500.0  | V <sub>k</sub> |                |           |           | 7.4       | 5.1       | 3.8       | 2.9       |      |      |
|           |       | X              | 1.5       | 1.0       | 0.7       | 0.6       |           |           |           |           |        | X              |                |           |           | 3.6       | 3.0       | 2.6       | 2.2       |      |      |
|           |       | P <sub>t</sub> | 40.9      | 8.2       | 2.6       | 1.1       |           |           |           |           |        |                | P <sub>t</sub> |           |           |           | 38        | 18.3      | 9.9       | 5.8  |      |
|           |       | NR             | 45        | 28        | 16        | 7         |           |           |           |           |        |                | NR             |           |           |           | 52        | 44        | 38        | 33   |      |
| 350       | 97.2  | V <sub>k</sub> | 8.9       | 4.0       | 2.2       | 1.4       | 1.0       |           |           | 2000      | 555.6  | V <sub>k</sub> |                |           |           |           | 5.7       | 4.2       | 3.2       |      |      |
|           |       | X              | 1.7       | 1.2       | 0.9       | 0.7       | 0.6       |           |           |           |        | X              |                |           |           |           | 3.3       | 2.9       | 2.5       |      |      |
|           |       | P <sub>t</sub> | 55.7      | 11.1      | 3.5       | 1.4       | 0.7       |           |           |           |        |                | P <sub>t</sub> |           |           |           |           | 22.6      | 12.2      | 7.1  |      |
|           |       | NR             | 49        | 32        | 20        | 11        | -         |           |           |           |        |                | NR             |           |           |           |           | 47        | 41        | 35   |      |
| 400       | 111.1 | V <sub>k</sub> |           | 4.6       | 2.6       | 1.6       | 1.1       |           |           | 2500      | 694.4  | V <sub>k</sub> |                |           |           |           |           | 7.1       | 5.2       | 4.0  |      |
|           |       | X              |           | 1.3       | 1.0       | 0.8       | 0.7       |           |           |           |        | X              |                |           |           |           |           | 4.2       | 3.6       | 3.1  |      |
|           |       | P <sub>t</sub> |           | 14.5      | 4.6       | 1.9       | 0.9       |           |           |           |        |                | P <sub>t</sub> |           |           |           |           |           | 35.3      | 19.1 | 11.2 |
|           |       | NR             |           | 35        | 24        | 15        | 7         |           |           |           |        |                | NR             |           |           |           |           |           | 52        | 46   | 41   |
| 450       | 125.0 | V <sub>k</sub> |           | 5.1       | 2.9       | 1.8       | 1.3       |           |           | 3000      | 833.3  | V <sub>k</sub> |                |           |           |           |           |           | 6.3       | 4.8  |      |
|           |       | X              |           | 1.5       | 1.1       | 0.9       | 0.7       |           |           |           |        | X              |                |           |           |           |           |           | 4.3       | 3.7  |      |
|           |       | P <sub>t</sub> |           | 18.4      | 5.8       | 2.4       | 1.1       |           |           |           |        |                | P <sub>t</sub> |           |           |           |           |           |           | 27.4 | 16.1 |
|           |       | NR             |           | 38        | 27        | 17        | 10        |           |           |           |        |                | NR             |           |           |           |           |           |           | 51   | 45   |
| 500       | 138.9 | V <sub>k</sub> |           | 5.7       | 3.2       | 2.0       | 1.4       |           |           | 3500      | 972.2  | V <sub>k</sub> |                |           |           |           |           |           | 7.3       | 5.6  |      |
|           |       | X              |           | 1.7       | 1.2       | 1.0       | 0.8       |           |           |           |        | X              |                |           |           |           |           |           | 5         | 4.4  |      |
|           |       | P <sub>t</sub> |           | 22.7      | 7.1       | 2.9       | 1.4       |           |           |           |        |                | P <sub>t</sub> |           |           |           |           |           |           | 37.3 | 21.9 |
|           |       | NR             |           | 41        | 29        | 20        | 13        |           |           |           |        |                | NR             |           |           |           |           |           |           | 54   | 49   |
| 600       | 166.7 | V <sub>k</sub> |           | 6.8       | 3.8       | 2.5       | 1.7       | 1.3       |           | 4000      | 1111.1 | V <sub>k</sub> |                |           |           |           |           |           | 8.3       | 6.4  |      |
|           |       | X              |           | 2.0       | 1.5       | 1.2       | 1.0       | 0.9       |           |           |        | X              |                |           |           |           |           |           | 5.7       | 5.0  |      |
|           |       | P <sub>t</sub> |           | 32.7      | 10.3      | 4.2       | 2.0       | 1.1       |           |           |        |                | P <sub>t</sub> |           |           |           |           |           |           | 48.8 | 28.6 |
|           |       | NR             |           | 45        | 34        | 25        | 17        | 11        |           |           |        |                | NR             |           |           |           |           |           |           | 58   | 52   |

**Symbols:**

A<sub>k</sub> - Effective area

V<sub>k</sub> - Effective velocity in m/s

X - Throw in metres correspond to a terminal velocity in occupied zone of 0.25m/s

Pressure (P<sub>t</sub>) - All pressures are in Pa (N/m²)

NR - Noise level index in dB based on a room absorption and one diffuser

## Supply Air Ceiling Grille

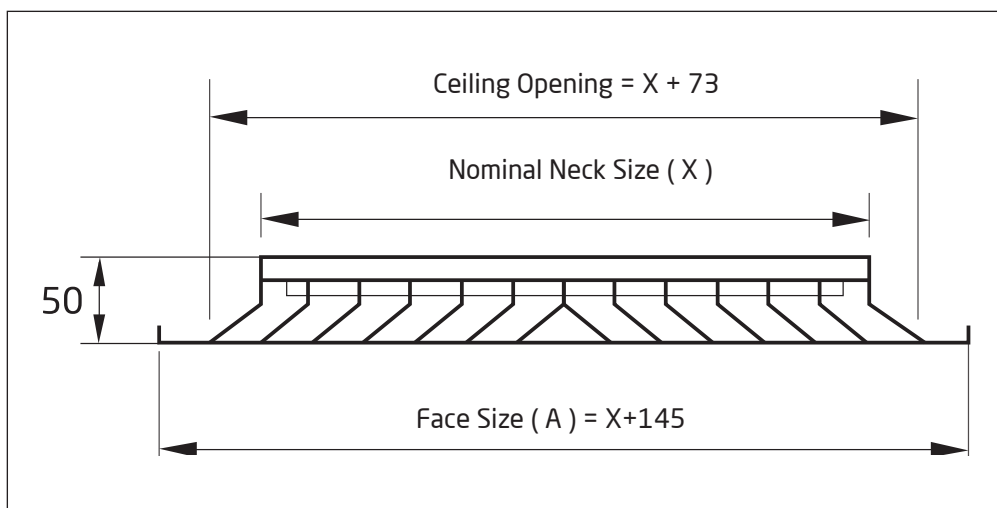

| Nominal Neck Metric ( X ) | Face Size ( A ) |
|---------------------------|-----------------|
| 150 x 150 mm              | 295 x 295 mm    |
| 225 x 225 mm              | 370 x 370 mm    |
| 300 x 300 mm              | 445 x 445 mm    |
| 375 x 375 mm              | 520 x 520 mm    |
| 450 x 450 mm              | 595 x 595 mm    |

\* Grilles are powder coated white as standard

\* The first number is for horizontal dimension and the second number is for vertical dimension

## Quick Selection Table

| Flow rate |       | Dim            | 150 x 150 | 225 x 225 | 300 x 300 | 375 x 375 | 450 x 450 | 525 x 525 | 600 x 600 | Flow rate |        | Dim            | 150 x 150      | 225 x 225 | 300 x 300 | 375 x 375 | 450 x 450 | 525 x 525 | 600 x 600 |     |
|-----------|-------|----------------|-----------|-----------|-----------|-----------|-----------|-----------|-----------|-----------|--------|----------------|----------------|-----------|-----------|-----------|-----------|-----------|-----------|-----|
| (m³/h)    | (l/s) | A <sub>k</sub> | 0.0109    | 0.0244    | 0.0435    | 0.0679    | 0.0978    | 0.1331    | 0.1739    | (m³/h)    | (l/s)  | A <sub>k</sub> | 0.0109         | 0.0244    | 0.0435    | 0.0679    | 0.0978    | 0.1331    | 0.1739    |     |
| 100       | 27.8  | V <sub>k</sub> | 2.5       | 1.1       |           |           |           |           |           | 700       | 194.4  | V <sub>k</sub> |                | 8.0       | 4.5       | 2.9       | 2.0       | 1.5       | 1.1       |     |
|           |       | X              | 0.5       | 0.3       |           |           |           |           |           |           |        | X              |                | 2.3       | 1.7       | 1.4       | 1.2       | 1.0       | 0.9       |     |
|           |       | P <sub>t</sub> | 4.5       | 0.9       |           |           |           |           |           |           |        |                | P <sub>t</sub> |           | 44.5      | 14.0      | 5.7       | 2.8       | 1.5       | 0.9 |
|           |       | NR             | 18        | -         |           |           |           |           |           |           |        |                | NR             |           | 49        | 37        | 28        | 21        | 15        | 9   |
| 120       | 33.3  | V <sub>k</sub> | 3.1       | 1.4       |           |           |           |           |           | 800       | 222.2  | V <sub>k</sub> |                |           | 5.1       | 3.3       | 2.3       | 1.7       | 1.3       |     |
|           |       | X              | 0.6       | 0.4       |           |           |           |           |           |           |        | X              |                |           | 2.0       | 1.6       | 1.3       | 1.1       | 1.0       |     |
|           |       | P <sub>t</sub> | 6.5       | 1.3       |           |           |           |           |           |           |        |                | P <sub>t</sub> |           |           | 18.3      | 7.5       | 3.6       | 2.0       | 1.1 |
|           |       | NR             | 22        | 6         |           |           |           |           |           |           |        |                | NR             |           |           | 41        | 32        | 24        | 18        | 12  |
| 140       | 38.9  | V <sub>k</sub> | 3.6       | 1.6       |           |           |           |           |           | 900       | 250.0  | V <sub>k</sub> |                |           | 5.7       | 3.7       | 2.6       | 1.9       | 1.4       |     |
|           |       | X              | 0.7       | 0.5       |           |           |           |           |           |           |        | X              |                |           | 2.2       | 1.8       | 1.5       | 1.3       | 1.1       |     |
|           |       | P <sub>t</sub> | 8.9       | 1.8       |           |           |           |           |           |           |        |                | P <sub>t</sub> |           |           | 23.1      | 9.5       | 4.6       | 2.5       | 1.4 |
|           |       | NR             | 26        | 9         |           |           |           |           |           |           |        |                | NR             |           |           | 44        | 35        | 27        | 21        | 15  |
| 160       | 44.4  | V <sub>k</sub> | 4.1       | 1.8       | 1.0       |           |           |           |           | 1000      | 277.8  | V <sub>k</sub> |                |           | 6.4       | 4.1       | 2.8       | 2.1       | 1.6       |     |
|           |       | X              | 0.8       | 0.5       | 0.4       |           |           |           |           |           |        | X              |                |           | 2.5       | 2.0       | 1.7       | 1.4       | 1.2       |     |
|           |       | P <sub>t</sub> | 11.6      | 2.3       | 0.7       |           |           |           |           |           |        |                | P <sub>t</sub> |           |           | 28.5      | 11.7      | 5.6       | 3.0       | 1.8 |
|           |       | NR             | 29        | 13        | -         |           |           |           |           |           |        |                | NR             |           |           | 46        | 37        | 30        | 23        | 18  |
| 180       | 50.0  | V <sub>k</sub> | 4.6       | 2.0       | 1.1       |           |           |           |           | 1200      | 333.3  | V <sub>k</sub> |                |           | 7.7       | 4.9       | 3.4       | 2.5       | 1.9       |     |
|           |       | X              | 0.9       | 0.6       | 0.4       |           |           |           |           |           |        | X              |                |           | 3.0       | 2.4       | 2.0       | 1.7       | 1.5       |     |
|           |       | P <sub>t</sub> | 14.7      | 2.9       | 0.9       |           |           |           |           |           |        |                | P <sub>t</sub> |           |           | 41.1      | 16.9      | 8.1       | 4.4       | 2.6 |
|           |       | NR             | 32        | 16        | -         |           |           |           |           |           |        |                | NR             |           |           | 51        | 42        | 34        | 28        | 23  |
| 200       | 55.6  | V <sub>k</sub> | 5.1       | 2.3       | 1.3       |           |           |           |           | 1400      | 388.9  | V <sub>k</sub> |                |           |           | 5.7       | 4.0       | 2.9       | 2.2       |     |
|           |       | X              | 1.0       | 0.7       | 0.5       |           |           |           |           |           |        | X              |                |           |           | 2.8       | 2.3       | 2.0       | 1.7       |     |
|           |       | P <sub>t</sub> | 18.2      | 3.6       | 1.1       |           |           |           |           |           |        |                | P <sub>t</sub> |           |           |           | 23        | 11.1      | 6.0       | 3.5 |
|           |       | NR             | 35        | 18        | 6         |           |           |           |           |           |        |                | NR             |           |           |           | 46        | 38        | 32        | 26  |
| 250       | 69.4  | V <sub>k</sub> | 6.4       | 2.8       | 1.6       | 1.0       |           |           |           | 1600      | 444.4  | V <sub>k</sub> |                |           |           | 6.5       | 4.5       | 3.3       | 2.6       |     |
|           |       | X              | 1.2       | 0.8       | 0.6       | 0.5       |           |           |           |           |        | X              |                |           |           | 3.2       | 2.7       | 2.3       | 2.0       |     |
|           |       | P <sub>t</sub> | 28.4      | 5.7       | 1.8       | 0.7       |           |           |           |           |        |                | P <sub>t</sub> |           |           |           | 30        | 14.5      | 7.8       | 4.6 |
|           |       | NR             | 40        | 24        | 12        | -         |           |           |           |           |        |                | NR             |           |           |           | 49        | 41        | 35        | 30  |
| 300       | 83.3  | V <sub>k</sub> | 7.6       | 3.4       | 1.9       | 1.2       |           |           |           | 1800      | 500.0  | V <sub>k</sub> |                |           |           | 7.4       | 5.1       | 3.8       | 2.9       |     |
|           |       | X              | 1.5       | 1.0       | 0.7       | 0.6       |           |           |           |           |        | X              |                |           |           | 3.6       | 3.0       | 2.6       | 2.2       |     |
|           |       | P <sub>t</sub> | 40.9      | 8.2       | 2.6       | 1.1       |           |           |           |           |        |                | P <sub>t</sub> |           |           |           | 38        | 18.3      | 9.9       | 5.8 |
|           |       | NR             | 45        | 28        | 16        | 7         |           |           |           |           |        |                | NR             |           |           |           | 52        | 44        | 38        | 33  |
| 350       | 97.2  | V <sub>k</sub> | 8.9       | 4.0       | 2.2       | 1.4       | 1.0       |           |           | 2000      | 555.6  | V <sub>k</sub> |                |           |           |           | 5.7       | 4.2       | 3.2       |     |
|           |       | X              | 1.7       | 1.2       | 0.9       | 0.7       | 0.6       |           |           |           |        |                | X              |           |           |           | 3.3       | 2.9       | 2.5       |     |
|           |       | P <sub>t</sub> | 55.7      | 11.1      | 3.5       | 1.4       | 0.7       |           |           |           |        |                | P <sub>t</sub> |           |           |           | 22.6      | 12.2      | 7.1       |     |
|           |       | NR             | 49        | 32        | 20        | 11        | -         |           |           |           |        |                | NR             |           |           |           | 47        | 41        | 35        |     |
| 400       | 111.1 | V <sub>k</sub> |           | 4.6       | 2.6       | 1.6       | 1.1       |           |           | 2500      | 694.4  | V <sub>k</sub> |                |           |           |           | 7.1       | 5.2       | 4.0       |     |
|           |       | X              |           | 1.3       | 1.0       | 0.8       | 0.7       |           |           |           |        |                | X              |           |           |           | 4.2       | 3.6       | 3.1       |     |
|           |       | P <sub>t</sub> |           | 14.5      | 4.6       | 1.9       | 0.9       |           |           |           |        |                | P <sub>t</sub> |           |           |           | 35.3      | 19.1      | 11.2      |     |
|           |       | NR             |           | 35        | 24        | 15        | 7         |           |           |           |        |                | NR             |           |           |           | 52        | 46        | 41        |     |
| 450       | 125.0 | V <sub>k</sub> |           | 5.1       | 2.9       | 1.8       | 1.3       |           |           | 3000      | 833.3  | V <sub>k</sub> |                |           |           |           |           | 6.3       | 4.8       |     |
|           |       | X              |           | 1.5       | 1.1       | 0.9       | 0.7       |           |           |           |        |                | X              |           |           |           |           | 4.3       | 3.7       |     |
|           |       | P <sub>t</sub> |           | 18.4      | 5.8       | 2.4       | 1.1       |           |           |           |        |                | P <sub>t</sub> |           |           |           |           | 27.4      | 16.1      |     |
|           |       | NR             |           | 38        | 27        | 17        | 10        |           |           |           |        |                | NR             |           |           |           |           | 51        | 45        |     |
| 500       | 138.9 | V <sub>k</sub> |           | 5.7       | 3.2       | 2.0       | 1.4       |           |           | 3500      | 972.2  | V <sub>k</sub> |                |           |           |           |           | 7.3       | 5.6       |     |
|           |       | X              |           | 1.7       | 1.2       | 1.0       | 0.8       |           |           |           |        |                | X              |           |           |           |           | 5         | 4.4       |     |
|           |       | P <sub>t</sub> |           | 22.7      | 7.1       | 2.9       | 1.4       |           |           |           |        |                | P <sub>t</sub> |           |           |           |           | 37.3      | 21.9      |     |
|           |       | NR             |           | 41        | 29        | 20        | 13        |           |           |           |        |                | NR             |           |           |           |           | 54        | 49        |     |
| 600       | 166.7 | V <sub>k</sub> |           | 6.8       | 3.8       | 2.5       | 1.7       | 1.3       |           | 4000      | 1111.1 | V <sub>k</sub> |                |           |           |           |           | 8.3       | 6.4       |     |
|           |       | X              |           | 2.0       | 1.5       | 1.2       | 1.0       | 0.9       |           |           |        |                | X              |           |           |           |           | 5.7       | 5.0       |     |
|           |       | P <sub>t</sub> |           | 32.7      | 10.3      | 4.2       | 2.0       | 1.1       |           |           |        |                | P <sub>t</sub> |           |           |           |           | 48.8      | 28.6      |     |
|           |       | NR             |           | 45        | 34        | 25        | 17        | 11        |           |           |        |                | NR             |           |           |           |           | 58        | 52        |     |

**Symbols:**

A<sub>k</sub> - Effective area

V<sub>k</sub> - Effective velocity in m/s

X - Throw in metres correspond to a terminal velocity in occupied zone of 0.25m/s

Pressure (P<sub>t</sub>) - All pressures are in Pa (N/m²)

NR - Noise level index in dB based on a room absorption and one diffuser



## Curved Blade Diffuser

### General Information:

As Ventech Curved Blade Diffuser the loose biscuit design can turn the diffuser into a multi directional outlet. For each blade it can also be adjusted individually which results in improved airflow control.

The Curved Blade Diffuser is suitable for heating, cooling or evaporative air distribution. Commonly used in ceiling or side wall applications where positive direction control is required. Individual adjustable blades make it easy to be closed off, avoiding draughts without the expense of any volume control damper.

### Features:

- All extruded aluminium frame and curved blades
- Other patterns are available on request
- Optional Opposed blade dampers, stream splitter dampers
- Size manufactured on request

# Curved Blade 1 Way Diffuser

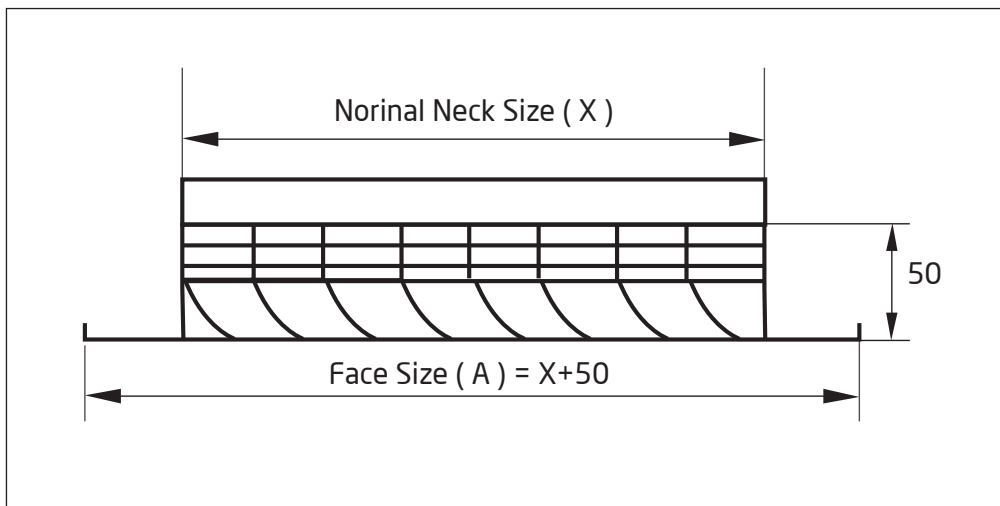
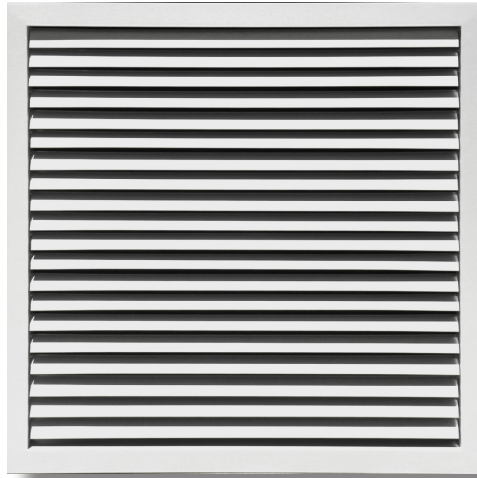

| Nominal Neck Metric ( X ) | Face Size ( A ) |
|---------------------------|-----------------|
| 150 x 150 mm              | 200 x 200 mm    |
| 225 x 225 mm              | 275 x 275 mm    |
| 300 x 300 mm              | 350 x 350 mm    |
| 375 x 375 mm              | 425 x 425 mm    |
| 450 x 450 mm              | 500 x 500 mm    |

\* Grilles are powder coated white as standard

\* The first number is for horizontal dimension and the second number is for vertical dimension

## Quick Selection Table

| Flow rate |       | Dim            | 150 x 150 | 225 x 225 | 300 x 300 | 375 x 375 | 450 x 450 | 525 x 525 | 600 x 600 | Flow rate |        | Dim            | 150 x 150      | 225 x 225 | 300 x 300 | 375 x 375 | 450 x 450 | 525 x 525 | 600 x 600 |      |      |      |      |
|-----------|-------|----------------|-----------|-----------|-----------|-----------|-----------|-----------|-----------|-----------|--------|----------------|----------------|-----------|-----------|-----------|-----------|-----------|-----------|------|------|------|------|
| (m³/h)    | (l/s) | A <sub>k</sub> | 0.0109    | 0.0244    | 0.0435    | 0.0679    | 0.0978    | 0.1331    | 0.1739    | (m³/h)    | (l/s)  | A <sub>k</sub> | 0.0109         | 0.0244    | 0.0435    | 0.0679    | 0.0978    | 0.1331    | 0.1739    |      |      |      |      |
| 100       | 27.8  | V <sub>k</sub> | 2.1       | 0.9       |           |           |           |           |           | 700       | 194.4  | V <sub>k</sub> |                | 6.4       | 3.6       | 2.3       | 1.6       | 1.2       | 0.9       |      |      |      |      |
|           |       | X              | 0.5       | 0.3       |           |           |           |           |           |           |        | X              |                | 2.3       | 1.7       | 1.4       | 1.2       | 1.0       | 0.9       |      |      |      |      |
|           |       | P <sub>t</sub> | 4.4       | 0.9       |           |           |           |           |           |           |        |                | P <sub>t</sub> |           | 43.6      | 13.7      | 5.6       | 2.7       | 1.5       | 0.9  |      |      |      |
|           |       | NR             | 17.5      | -         |           |           |           |           |           |           |        |                | NR             |           | 47.5      | 35.9      | 27.2      | 20.4      | 14.6      | 8.7  |      |      |      |
| 120       | 33.3  | V <sub>k</sub> | 2.5       | 1.1       |           |           |           |           |           | 800       | 222.2  | V <sub>k</sub> |                |           | 4.1       | 2.6       | 1.8       | 1.4       | 1.0       |      |      |      |      |
|           |       | X              | 0.6       | 0.4       |           |           |           |           |           |           |        | X              |                |           | 2.0       | 1.6       | 1.3       | 1.1       | 1.0       |      |      |      |      |
|           |       | P <sub>t</sub> | 6.4       | 1.3       |           |           |           |           |           |           |        |                | P <sub>t</sub> |           |           | 17.9      | 7.4       | 3.5       | 2.0       | 1.1  |      |      |      |
|           |       | NR             | 21.3      | 5.8       |           |           |           |           |           |           |        |                | NR             |           |           | 39.8      | 31.0      | 23.3      | 17.5      | 11.6 |      |      |      |
| 140       | 38.9  | V <sub>k</sub> | 2.9       | 1.3       |           |           |           |           |           | 900       | 250.0  | V <sub>k</sub> |                |           | 4.6       | 3.0       | 2.1       | 1.5       | 1.1       |      |      |      |      |
|           |       | X              | 0.7       | 0.5       |           |           |           |           |           |           |        | X              |                |           | 2.2       | 1.8       | 1.5       | 1.3       | 1.1       |      |      |      |      |
|           |       | P <sub>t</sub> | 8.7       | 1.8       |           |           |           |           |           |           |        |                | P <sub>t</sub> |           |           | 22.6      | 9.3       | 4.5       | 2.5       | 1.4  |      |      |      |
|           |       | NR             | 25.2      | 8.7       |           |           |           |           |           |           |        |                | NR             |           |           | 42.7      | 34.0      | 26.2      | 20.4      | 14.6 |      |      |      |
| 160       | 44.4  | V <sub>k</sub> | 3.3       | 1.4       | 0.8       |           |           |           |           | 1000      | 277.8  | V <sub>k</sub> |                |           | 5.1       | 3.3       | 2.2       | 1.7       | 1.3       |      |      |      |      |
|           |       | X              | 0.8       | 0.5       | 0.4       |           |           |           |           |           |        | X              |                |           | 2.5       | 2.0       | 1.7       | 1.4       | 1.2       |      |      |      |      |
|           |       | P <sub>t</sub> | 11.4      | 2.3       | 0.7       |           |           |           |           |           |        |                | P <sub>t</sub> |           |           | 27.9      | 11.5      | 5.5       | 2.9       | 1.8  |      |      |      |
|           |       | NR             | 28.1      | 12.6      | -         |           |           |           |           |           |        |                | NR             |           |           | 44.6      | 35.9      | 29.1      | 22.3      | 17.5 |      |      |      |
| 180       | 50.0  | V <sub>k</sub> | 3.7       | 1.6       | 0.9       |           |           |           |           | 1200      | 333.3  | V <sub>k</sub> |                |           | 6.2       | 3.9       | 2.7       | 2.0       | 1.5       |      |      |      |      |
|           |       | X              | 0.9       | 0.6       | 0.4       |           |           |           |           |           |        | X              |                |           | 3.0       | 2.4       | 2.0       | 1.7       | 1.5       |      |      |      |      |
|           |       | P <sub>t</sub> | 14.4      | 2.8       | 0.9       |           |           |           |           |           |        |                | P <sub>t</sub> |           |           | 40.3      | 16.6      | 7.9       | 4.3       | 2.5  |      |      |      |
|           |       | NR             | 31.0      | 15.5      | -         |           |           |           |           |           |        |                | NR             |           |           | 49.5      | 40.7      | 33.0      | 27.2      | 22.3 |      |      |      |
| 200       | 55.6  | V <sub>k</sub> | 4.1       | 1.8       | 1.0       |           |           |           |           | 1400      | 388.9  | V <sub>k</sub> |                |           |           | 4.6       | 3.2       | 2.3       | 1.8       |      |      |      |      |
|           |       | X              | 1.0       | 0.7       | 0.5       |           |           |           |           |           |        | X              |                |           |           | 2.8       | 2.3       | 2.0       | 1.7       |      |      |      |      |
|           |       | P <sub>t</sub> | 17.8      | 3.5       | 1.1       |           |           |           |           |           |        |                | P <sub>t</sub> |           |           |           | 22.5      | 10.9      | 5.9       | 3.4  |      |      |      |
|           |       | NR             | 34.0      | 17.5      | 5.8       |           |           |           |           |           |        |                | NR             |           |           |           | 44.6      | 36.9      | 31.0      | 25.2 |      |      |      |
| 250       | 69.4  | V <sub>k</sub> | 5.1       | 2.2       | 1.3       | 0.8       |           |           |           | 1600      | 444.4  | V <sub>k</sub> |                |           |           | 5.2       | 3.6       | 3.3       | 2.6       |      |      |      |      |
|           |       | X              | 1.2       | 0.8       | 0.6       | 0.5       |           |           |           |           |        | X              |                |           |           | 3.2       | 2.7       | 1.8       | 1.6       |      |      |      |      |
|           |       | P <sub>t</sub> | 27.8      | 5.6       | 1.8       | 0.7       |           |           |           |           |        |                | P <sub>t</sub> |           |           |           | 29.4      | 14.2      | 7.6       | 4.5  |      |      |      |
|           |       | NR             | 38.8      | 23.3      | 11.6      | -         |           |           |           |           |        |                | NR             |           |           |           | 47.5      | 39.8      | 34.0      | 29.1 |      |      |      |
| 300       | 83.3  | V <sub>k</sub> | 6.1       | 2.7       | 1.5       | 1.0       |           |           |           | 1800      | 500.0  | V <sub>k</sub> |                |           |           | 5.9       | 4.1       | 3.0       | 2.3       |      |      |      |      |
|           |       | X              | 1.5       | 1.0       | 0.7       | 0.6       |           |           |           |           |        | X              |                |           |           | 3.6       | 3.0       | 2.6       | 2.2       |      |      |      |      |
|           |       | P <sub>t</sub> | 40.1      | 8.0       | 2.5       | 1.1       |           |           |           |           |        |                | P <sub>t</sub> |           |           |           | 37.2      | 17.9      | 9.7       | 5.7  |      |      |      |
|           |       | NR             | 43.7      | 27.2      | 15.5      | 6.8       |           |           |           |           |        |                | NR             |           |           |           | 50.4      | 42.7      | 36.9      | 32.0 |      |      |      |
| 350       | 97.2  | V <sub>k</sub> | 7.1       | 3.2       | 1.8       | 1.1       | 0.8       |           |           | 2000      | 555.6  | V <sub>k</sub> |                |           |           |           | 4.6       | 3.4       | 2.6       |      |      |      |      |
|           |       | X              | 1.7       | 1.2       | 0.9       | 0.7       | 0.6       |           |           |           |        | X              |                |           |           |           | 3.3       | 2.9       | 2.5       |      |      |      |      |
|           |       | P <sub>t</sub> | 54.6      | 10.9      | 3.4       | 1.4       | 0.7       |           |           |           |        |                | P <sub>t</sub> |           |           |           |           | 22.1      | 12.0      | 7.0  |      |      |      |
|           |       | NR             | 47.5      | 31.0      | 19.4      | 10.7      | -         |           |           |           |        |                | NR             |           |           |           |           | 45.6      | 39.8      | 34.0 |      |      |      |
| 400       | 111.1 | V <sub>k</sub> |           | 3.7       | 2.1       | 1.3       | 0.9       |           |           | 2500      | 694.4  | V <sub>k</sub> |                |           |           |           |           | 5.7       | 4.2       | 3.2  |      |      |      |
|           |       | X              |           | 1.3       | 1.0       | 0.8       | 0.7       |           |           |           |        | X              |                |           |           |           |           | 4.2       | 3.6       | 3.1  |      |      |      |
|           |       | P <sub>t</sub> |           | 14.2      | 4.5       | 1.9       | 0.9       |           |           |           |        |                | P <sub>t</sub> |           |           |           |           |           | 34.6      | 18.7 | 11.0 |      |      |
|           |       | NR             |           | 34.0      | 23.3      | 14.6      | 6.8       |           |           |           |        |                | NR             |           |           |           |           |           | 50.4      | 44.6 | 39.8 |      |      |
| 450       | 125.0 | V <sub>k</sub> |           | 4.1       | 2.3       | 1.4       | 1.0       |           |           | 3000      | 833.3  | V <sub>k</sub> |                |           |           |           |           |           | 5.0       | 3.8  |      |      |      |
|           |       | X              |           | 1.5       | 1.1       | 0.9       | 0.7       |           |           |           |        | X              |                |           |           |           |           |           | 4.3       | 3.7  |      |      |      |
|           |       | P <sub>t</sub> |           | 18.0      | 5.7       | 2.4       | 1.1       |           |           |           |        |                | P <sub>t</sub> |           |           |           |           |           |           | 26.9 | 15.8 |      |      |
|           |       | NR             |           | 36.9      | 26.2      | 16.5      | 9.7       |           |           |           |        |                | NR             |           |           |           |           |           |           | 49.5 | 43.7 |      |      |
| 500       | 138.9 | V <sub>k</sub> |           | 4.6       | 2.6       | 1.6       | 1.1       |           |           | 3500      | 972.2  | V <sub>k</sub> |                |           |           |           |           |           |           | 5.8  | 4.5  |      |      |
|           |       | X              |           | 1.7       | 1.2       | 1.0       | 0.8       |           |           |           |        | X              |                |           |           |           |           |           |           | 5.0  | 4.4  |      |      |
|           |       | P <sub>t</sub> |           | 22.2      | 7.0       | 2.8       | 1.4       |           |           |           |        |                | P <sub>t</sub> |           |           |           |           |           |           |      | 36.6 | 21.5 |      |
|           |       | NR             |           | 39.8      | 28.1      | 19.4      | 12.6      |           |           |           |        |                | NR             |           |           |           |           |           |           |      | 52.4 | 47.5 |      |
| 600       | 166.7 | V <sub>k</sub> |           | 5.4       | 3.0       | 2.0       | 1.4       | 1.0       |           | 4000      | 1111.1 | V <sub>k</sub> |                |           |           |           |           |           |           |      | 6.6  | 5.1  |      |
|           |       | X              |           | 2.0       | 1.5       | 1.2       | 1.0       | 0.9       |           |           |        | X              |                |           |           |           |           |           |           |      | 5.7  | 5.0  |      |
|           |       | P <sub>t</sub> |           | 32.0      | 10.1      | 4.1       | 2.0       | 1.1       |           |           |        |                | P <sub>t</sub> |           |           |           |           |           |           |      |      | 47.8 | 28.0 |
|           |       | NR             |           | 43.7      | 33.0      | 24.3      | 16.5      | 10.7      |           |           |        |                | NR             |           |           |           |           |           |           |      |      | 56.3 | 52.0 |

\* This table only be used for single way Curved Blade Diffuser products

Symbols:

A<sub>k</sub> - Effective area

V<sub>k</sub> - Effective velocity in m/s

X - Throw in metres correspond to a terminal velocity in occupied zone of 0.25m/s

Pressure (P<sub>t</sub>) - All pressures are in Pa (N/m²)

# Curved Blade 2 Way Diffuser

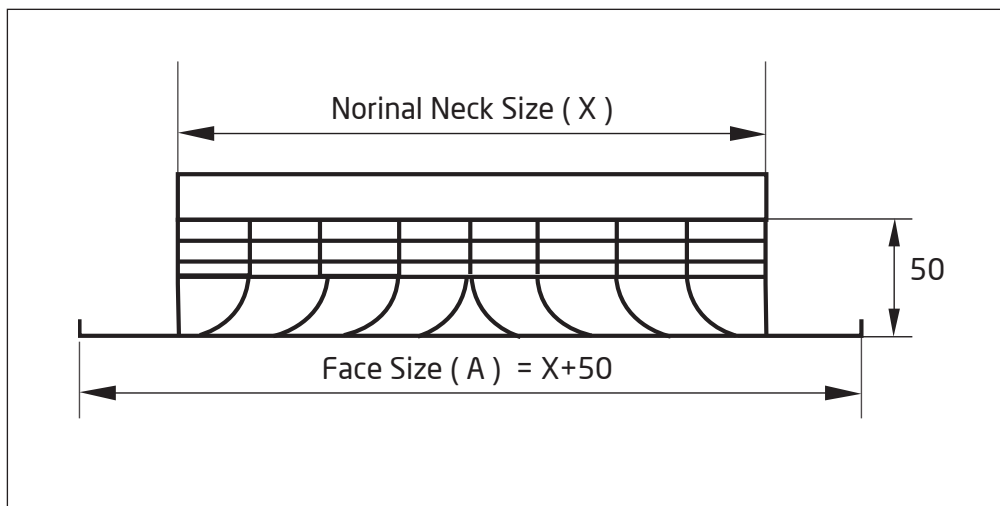
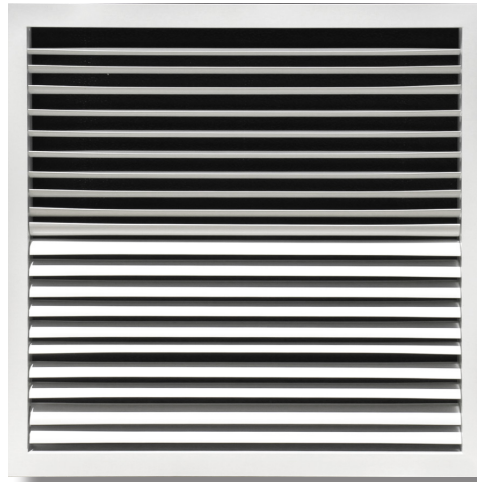

| Nominal Neck Metric ( X ) | Face Size ( A ) |
|---------------------------|-----------------|
| 150 x 150 mm              | 200 x 200 mm    |
| 225 x 225 mm              | 275 x 275 mm    |
| 300 x 300 mm              | 350 x 350 mm    |
| 375 x 375 mm              | 425 x 425 mm    |
| 450 x 450 mm              | 500 x 500 mm    |

\* Grilles are powder coated white as standard

\* The first number is for horizontal dimension and the second number is for vertical dimension



## Bevelled Edge Diffuser

### General Information:

Bevelled Edge Diffuser is also a surface mounting model. The 45 degree bevelled frame combines attractive appearance with the advantage of a built-in anti-smudge frame for increased ceiling protection. Used mainly in a domestic capacity and is extremely effective in providing an even spread of air across the target area.

### Features:

- Supply or return air applications
- Complete assembly from extruded aluminium sections
- Rigid, heavy gauge extruded frames with reinforced mitered and welded corners
- Special patterns are available  
(Optional opposed blade damper)
- Powder coating finish, standard color white
- Size manufactured on request

# Bevelled Edge 4 Way Diffuser

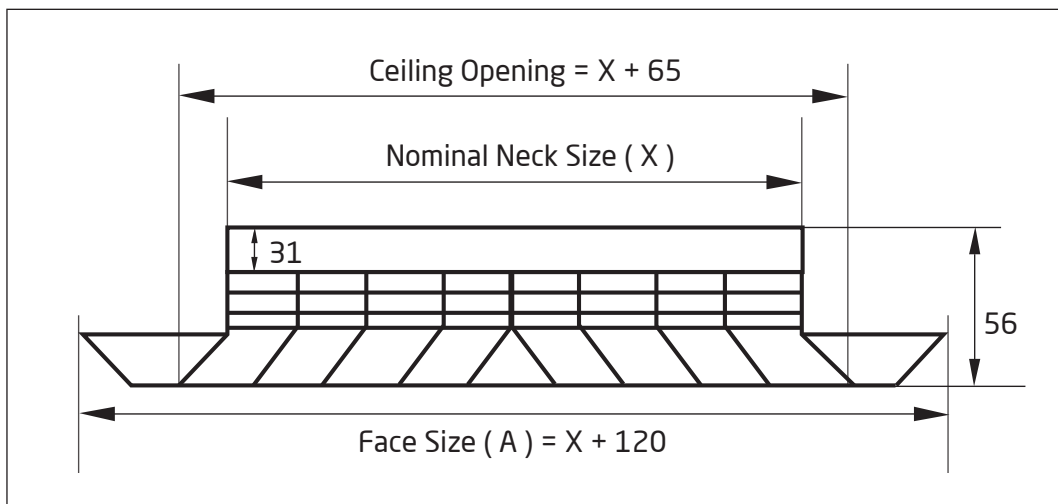

| Nominal Neck Metric ( X ) | Face Size ( A ) |
|---------------------------|-----------------|
| 150 x 150 mm              | 270 x 270 mm    |
| 225 x 225 mm              | 345 x 345 mm    |
| 300 x 300 mm              | 420 x 420 mm    |
| 375 x 375 mm              | 495 x 495 mm    |
| 450 x 450 mm              | 570 x 570 mm    |
| 525 x 525 mm              | 645 x 645 mm    |
| 600 x 600 mm              | 720 x 720 mm    |

\* Grilles are powder coated white as standard

\* The first number is for horizontal dimension and the second number is for vertical dimension

## Quick Selection Table

| Flow rate |       | Dim            | 150 x 150 | 225 x 225 | 300 x 300 | 375 x 375 | 450 x 450 | 525 x 525 | 600 x 600 | Flow rate |       | Dim            | 150 x 150      | 225 x 225 | 300 x 300 | 375 x 375 | 450 x 450 | 525 x 525 | 600 x 600 |     |  |
|-----------|-------|----------------|-----------|-----------|-----------|-----------|-----------|-----------|-----------|-----------|-------|----------------|----------------|-----------|-----------|-----------|-----------|-----------|-----------|-----|--|
| (m³/h)    | (l/s) | A <sub>k</sub> | 0.0096    | 0.0215    | 0.0383    | 0.0598    | 0.0863    | 0.1174    | 0.1534    | (m³/h)    | (l/s) | A <sub>k</sub> | 0.0096         | 0.0215    | 0.0383    | 0.0598    | 0.0863    | 0.1174    | 0.1534    |     |  |
| 50        | 13.9  | V <sub>k</sub> | 1.4       |           |           |           |           |           |           | 350       | 97.2  | V <sub>k</sub> |                | 4.5       | 2.5       | 1.6       | 1.1       | 0.8       |           |     |  |
|           |       | X              | 0.9       |           |           |           |           |           |           |           |       | X              |                | 4.1       | 3.1       | 2.5       | 2.0       | 1.8       |           |     |  |
|           |       | P <sub>t</sub> | 1.5       |           |           |           |           |           |           |           |       |                | P <sub>t</sub> |           | 14.3      | 4.5       | 1.9       | 0.9       | 0.5       |     |  |
|           |       | NR             | -         |           |           |           |           |           |           |           |       |                | NR             |           | 36        | 24        | 15        | 7         | -         |     |  |
| 60        | 16.7  | V <sub>k</sub> | 1.7       |           |           |           |           |           |           | 400       | 111.1 | V <sub>k</sub> |                | 5.2       | 2.9       | 1.9       | 1.3       | 0.9       |           |     |  |
|           |       | X              | 1.1       |           |           |           |           |           |           |           |       | X              |                | 4.7       | 3.5       | 2.8       | 2.3       | 2.0       |           |     |  |
|           |       | P <sub>t</sub> | 2.1       |           |           |           |           |           |           |           |       |                | P <sub>t</sub> |           | 18.7      | 5.9       | 2.4       | 1.2       | 0.6       |     |  |
|           |       | NR             | 9         |           |           |           |           |           |           |           |       |                | NR             |           | 39        | 27        | 18        | 10        | -         |     |  |
| 70        | 19.4  | V <sub>k</sub> | 2.0       | 0.9       |           |           |           |           |           | 500       | 138.9 | V <sub>k</sub> |                | 6.5       | 3.6       | 2.3       | 1.6       | 1.2       | 0.9       |     |  |
|           |       | X              | 1.2       | 0.8       |           |           |           |           |           |           |       | X              |                | 5.8       | 4.4       | 3.5       | 2.9       | 2.5       | 2.2       |     |  |
|           |       | P <sub>t</sub> | 2.9       | 0.6       |           |           |           |           |           |           |       |                | P <sub>t</sub> |           | 29.2      | 9.2       | 3.8       | 1.8       | 1.0       | 0.6 |  |
|           |       | NR             | 13        | -         |           |           |           |           |           |           |       |                | NR             |           | 45        | 33        | 23        | 16        | 9         | -   |  |
| 80        | 22.2  | V <sub>k</sub> | 2.3       | 1.0       |           |           |           |           |           | 600       | 166.7 | V <sub>k</sub> |                |           | 4.4       | 2.8       | 1.9       | 1.4       | 1.1       |     |  |
|           |       | X              | 1.4       | 0.9       |           |           |           |           |           |           |       | X              |                |           | 5.3       | 4.2       | 3.5       | 3.0       | 2.6       |     |  |
|           |       | P <sub>t</sub> | 3.8       | 0.7       |           |           |           |           |           |           |       |                | P <sub>t</sub> |           |           | 13.3      | 5.4       | 2.6       | 1.4       | 0.8 |  |
|           |       | NR             | 16        | -         |           |           |           |           |           |           |       |                | NR             |           |           | 37        | 28        | 20        | 14        | 8   |  |
| 90        | 25.0  | V <sub>k</sub> | 2.6       | 1.2       |           |           |           |           |           | 700       | 194.4 | V <sub>k</sub> |                |           | 5.1       | 3.3       | 2.3       | 1.7       | 1.3       |     |  |
|           |       | X              | 1.6       | 1.1       |           |           |           |           |           |           |       | X              |                |           | 6.1       | 4.9       | 4.1       | 3.5       | 3.1       |     |  |
|           |       | P <sub>t</sub> | 4.7       | 0.9       |           |           |           |           |           |           |       |                | P <sub>t</sub> |           |           | 18.0      | 7.4       | 3.6       | 1.9       | 1.1 |  |
|           |       | NR             | 19        | -         |           |           |           |           |           |           |       |                | NR             |           |           | 41        | 32        | 24        | 18        | 12  |  |
| 100       | 27.8  | V <sub>k</sub> | 2.9       | 1.3       |           |           |           |           |           | 800       | 222.2 | V <sub>k</sub> |                |           | 5.8       | 3.7       | 2.6       | 1.9       | 1.4       |     |  |
|           |       | X              | 1.8       | 1.2       |           |           |           |           |           |           |       | X              |                |           | 7.0       | 5.6       | 4.7       | 4.0       | 3.5       |     |  |
|           |       | P <sub>t</sub> | 5.9       | 1.2       |           |           |           |           |           |           |       |                | P <sub>t</sub> |           |           | 23.6      | 9.7       | 4.6       | 2.5       | 1.5 |  |
|           |       | NR             | 22        | 5         |           |           |           |           |           |           |       |                | NR             |           |           | 44        | 35        | 27        | 21        | 15  |  |
| 120       | 33.3  | V <sub>k</sub> | 3.5       | 1.6       | 0.9       |           |           |           |           | 900       | 250.0 | V <sub>k</sub> |                |           | 6.5       | 4.2       | 2.9       | 2.1       | 1.6       |     |  |
|           |       | X              | 2.1       | 1.4       | 1.1       |           |           |           |           |           |       | X              |                |           | 7.9       | 6.3       | 5.3       | 4.5       | 3.9       |     |  |
|           |       | P <sub>t</sub> | 8.4       | 1.7       | 0.5       |           |           |           |           |           |       |                | P <sub>t</sub> |           |           | 29.8      | 12.2      | 5.9       | 3.2       | 1.9 |  |
|           |       | NR             | 26        | 9         | -         |           |           |           |           |           |       |                | NR             |           |           | 47        | 38        | 30        | 24        | 18  |  |
| 140       | 38.9  | V <sub>k</sub> | 4.1       | 1.8       | 1.0       |           |           |           |           | 1000      | 277.8 | V <sub>k</sub> |                |           |           | 4.6       | 3.2       | 2.4       | 1.8       |     |  |
|           |       | X              | 2.5       | 1.6       | 1.2       |           |           |           |           |           |       | X              |                |           |           | 7.0       | 5.8       | 5.0       | 4.4       |     |  |
|           |       | P <sub>t</sub> | 11.5      | 2.3       | 0.7       |           |           |           |           |           |       |                | P <sub>t</sub> |           |           |           | 15.1      | 7.3       | 3.9       | 2.3 |  |
|           |       | NR             | 30        | 13        | -         |           |           |           |           |           |       |                | NR             |           |           |           | 41        | 33        | 26        | 21  |  |
| 160       | 44.4  | V <sub>k</sub> | 4.6       | 2.1       | 1.2       |           |           |           |           | 1200      | 333.3 | V <sub>k</sub> |                |           |           | 5.6       | 3.9       | 2.8       | 2.2       |     |  |
|           |       | X              | 2.8       | 1.9       | 1.4       |           |           |           |           |           |       | X              |                |           |           | 8.4       | 7.0       | 6.0       | 5.3       |     |  |
|           |       | P <sub>t</sub> | 15.0      | 3.0       | 0.9       |           |           |           |           |           |       |                | P <sub>t</sub> |           |           |           | 21.7      | 10.4      | 5.6       | 3.3 |  |
|           |       | NR             | 33        | 16        | -         |           |           |           |           |           |       |                | NR             |           |           |           | 45        | 37        | 31        | 25  |  |
| 180       | 50.0  | V <sub>k</sub> | 5.2       | 2.3       | 1.3       |           |           |           |           | 1400      | 388.9 | V <sub>k</sub> |                |           |           | 6.5       | 4.5       | 3.3       | 2.5       |     |  |
|           |       | X              | 3.2       | 2.1       | 1.6       |           |           |           |           |           |       | X              |                |           |           | 9.8       | 8.2       | 7.0       | 6.1       |     |  |
|           |       | P <sub>t</sub> | 19.0      | 3.8       | 1.2       |           |           |           |           |           |       |                | P <sub>t</sub> |           |           |           | 29.6      | 14.2      | 7.7       | 4.5 |  |
|           |       | NR             | 36        | 19        | 7         |           |           |           |           |           |       |                | NR             |           |           |           | 49        | 41        | 35        | 29  |  |
| 200       | 55.6  | V <sub>k</sub> | 5.8       | 2.6       | 1.5       | 0.9       |           |           |           | 1600      | 444.4 | V <sub>k</sub> |                |           |           |           | 5.1       | 3.8       | 2.9       |     |  |
|           |       | X              | 3.5       | 2.3       | 1.8       | 1.4       |           |           |           |           |       | X              |                |           |           | 9.3       | 8.0       | 7.0       |           |     |  |
|           |       | P <sub>t</sub> | 23.4      | 4.7       | 1.5       | 0.6       |           |           |           |           |       |                | P <sub>t</sub> |           |           |           | 18.6      | 10.0      | 5.9       |     |  |
|           |       | NR             | 39        | 22        | 10        | -         |           |           |           |           |       |                | NR             |           |           |           | 44        | 38        | 33        |     |  |
| 250       | 69.4  | V <sub>k</sub> | 7.2       | 3.2       | 1.8       | 1.2       | 0.8       |           |           | 1800      | 500.0 | V <sub>k</sub> |                |           |           |           | 5.8       | 4.3       | 3.3       |     |  |
|           |       | X              | 4.4       | 2.9       | 2.2       | 1.8       | 1.5       |           |           |           |       | X              |                |           |           | 10.5      | 9.0       | 7.9       |           |     |  |
|           |       | P <sub>t</sub> | 36.6      | 7.3       | 2.3       | 0.9       | 0.5       |           |           |           |       |                | P <sub>t</sub> |           |           |           | 23.5      | 12.7      | 7.4       |     |  |
|           |       | NR             | 44        | 28        | 15        | 6         | -         |           |           |           |       |                | NR             |           |           |           | 47        | 41        | 35        |     |  |
| 300       | 83.3  | V <sub>k</sub> |           | 3.9       | 2.2       | 1.4       | 1.0       |           |           | 2000      | 555.6 | V <sub>k</sub> |                |           |           |           | 6.4       | 4.7       | 3.6       |     |  |
|           |       | X              |           | 3.5       | 2.6       | 2.1       | 1.8       |           |           |           |       | X              |                |           |           | 11.7      | 10.0      | 8.8       |           |     |  |
|           |       | P <sub>t</sub> |           | 10.5      | 3.3       | 1.4       | 0.7       |           |           |           |       |                | P <sub>t</sub> |           |           |           | 29.0      | 15.7      | 9.2       |     |  |
|           |       | NR             |           | 32        | 20        | 11        | -         |           |           |           |       |                | NR             |           |           |           | 50        | 44        | 38        |     |  |

Symbols:

A<sub>k</sub> - Effective area

V<sub>k</sub> - Effective velocity in m/s

X - Throw in metres correspond to a terminal velocity in occupied zone of 0.25m/s

Pressure (P<sub>t</sub>) - All pressures are in Pa (N/m²)

NR - Noise level index in dB based on a room absorption and one diffuser

## Quick Selection Table

| Flow rate |       | Dim            | 150 x 150 | 225 x 225 | 300 x 300 | 375 x 375 | 450 x 450 | 525 x 525 | 600 x 160 | Flow rate |        | Dim            | 150 x 150 | 225 x 225      | 300 x 300 | 375 x 375 | 450 x 450 | 525 x 525 | 600 x 160 |      |      |
|-----------|-------|----------------|-----------|-----------|-----------|-----------|-----------|-----------|-----------|-----------|--------|----------------|-----------|----------------|-----------|-----------|-----------|-----------|-----------|------|------|
| (m³/h)    | (l/s) | A <sub>k</sub> | 0.0109    | 0.0244    | 0.0435    | 0.0679    | 0.0978    | 0.1331    | 0.1739    | (m³/h)    | (l/s)  | A <sub>k</sub> | 0.0109    | 0.0244         | 0.0435    | 0.0679    | 0.0978    | 0.1331    | 0.1739    |      |      |
| 100       | 27.8  | V <sub>k</sub> | 2.5       | 1.1       |           |           |           |           |           | 700       | 194.4  | V <sub>k</sub> |           | 8.0            | 4.5       | 2.9       | 2.0       | 1.5       | 1.1       |      |      |
|           |       | X              | 0.5       | 0.3       |           |           |           |           |           |           |        |                | X         |                | 2.3       | 1.7       | 1.4       | 1.2       | 1.0       | 0.9  |      |
|           |       | P <sub>t</sub> | 4.5       | 0.9       |           |           |           |           |           |           |        |                |           | P <sub>t</sub> |           | 44.5      | 14.0      | 5.7       | 2.8       | 1.5  | 0.9  |
|           |       | NR             | 18        | -         |           |           |           |           |           |           |        |                |           | NR             |           | 49        | 37        | 28        | 21        | 15   | 9    |
| 120       | 33.3  | V <sub>k</sub> | 3.1       | 1.4       |           |           |           |           |           | 800       | 222.2  | V <sub>k</sub> |           |                | 5.1       | 3.3       | 2.3       | 1.7       | 1.3       |      |      |
|           |       | X              | 0.6       | 0.4       |           |           |           |           |           |           |        |                | X         |                | 2.0       | 1.6       | 1.3       | 1.1       | 1.0       |      |      |
|           |       | P <sub>t</sub> | 6.5       | 1.3       |           |           |           |           |           |           |        |                |           | P <sub>t</sub> |           | 18.3      | 7.5       | 3.6       | 2.0       | 1.1  |      |
|           |       | NR             | 22        | 6         |           |           |           |           |           |           |        |                |           | NR             |           | 41        | 32        | 24        | 18        | 12   |      |
| 140       | 38.9  | V <sub>k</sub> | 3.6       | 1.6       |           |           |           |           |           | 900       | 250.0  | V <sub>k</sub> |           |                | 5.7       | 3.7       | 2.6       | 1.9       | 1.4       |      |      |
|           |       | X              | 0.7       | 0.5       |           |           |           |           |           |           |        |                | X         |                | 2.2       | 1.8       | 1.5       | 1.3       | 1.1       |      |      |
|           |       | P <sub>t</sub> | 8.9       | 1.8       |           |           |           |           |           |           |        |                |           | P <sub>t</sub> |           | 23.1      | 9.5       | 4.6       | 2.5       | 1.4  |      |
|           |       | NR             | 26        | 9         |           |           |           |           |           |           |        |                |           | NR             |           | 44        | 35        | 27        | 21        | 15   |      |
| 160       | 44.4  | V <sub>k</sub> | 4.1       | 1.8       | 1.0       |           |           |           |           | 1000      | 277.8  | V <sub>k</sub> |           |                | 6.4       | 4.1       | 2.8       | 2.1       | 1.6       |      |      |
|           |       | X              | 0.8       | 0.5       | 0.4       |           |           |           |           |           |        |                | X         |                | 2.5       | 2.0       | 1.7       | 1.4       | 1.2       |      |      |
|           |       | P <sub>t</sub> | 11.6      | 2.3       | 0.7       |           |           |           |           |           |        |                |           | P <sub>t</sub> |           | 28.5      | 11.7      | 5.6       | 3.0       | 1.8  |      |
|           |       | NR             | 29        | 13        | -         |           |           |           |           |           |        |                |           | NR             |           | 46        | 37        | 30        | 23        | 18   |      |
| 180       | 50.0  | V <sub>k</sub> | 4.6       | 2.0       | 1.1       |           |           |           |           | 1200      | 333.3  | V <sub>k</sub> |           |                | 7.7       | 4.9       | 3.4       | 2.5       | 1.9       |      |      |
|           |       | X              | 0.9       | 0.6       | 0.4       |           |           |           |           |           |        |                | X         |                | 3.0       | 2.4       | 2.0       | 1.7       | 1.5       |      |      |
|           |       | P <sub>t</sub> | 14.7      | 2.9       | 0.9       |           |           |           |           |           |        |                |           | P <sub>t</sub> |           | 41.1      | 16.9      | 8.1       | 4.4       | 2.6  |      |
|           |       | NR             | 32        | 16        | -         |           |           |           |           |           |        |                |           | NR             |           | 51        | 42        | 34        | 28        | 23   |      |
| 200       | 55.6  | V <sub>k</sub> | 5.1       | 2.3       | 1.3       |           |           |           |           | 1400      | 388.9  | V <sub>k</sub> |           |                |           | 5.7       | 4.0       | 2.9       | 2.2       |      |      |
|           |       | X              | 1.0       | 0.7       | 0.5       |           |           |           |           |           |        |                | X         |                | 2.8       | 2.3       | 2.0       | 1.7       |           |      |      |
|           |       | P <sub>t</sub> | 18.2      | 3.6       | 1.1       |           |           |           |           |           |        |                |           | P <sub>t</sub> |           | 23        | 11.1      | 6.0       | 3.5       |      |      |
|           |       | NR             | 35        | 18        | 6         |           |           |           |           |           |        |                |           | NR             |           | 46        | 38        | 32        | 26        |      |      |
| 250       | 69.4  | V <sub>k</sub> | 6.4       | 2.8       | 1.6       | 1.0       |           |           |           | 1600      | 444.4  | V <sub>k</sub> |           |                |           | 6.5       | 4.5       | 3.3       | 2.6       |      |      |
|           |       | X              | 1.2       | 0.8       | 0.6       | 0.5       |           |           |           |           |        |                | X         |                | 3.2       | 2.7       | 2.3       | 2.0       |           |      |      |
|           |       | P <sub>t</sub> | 28.4      | 5.7       | 1.8       | 0.7       |           |           |           |           |        |                |           | P <sub>t</sub> |           | 30        | 14.5      | 7.8       | 4.6       |      |      |
|           |       | NR             | 40        | 24        | 12        | -         |           |           |           |           |        |                |           | NR             |           | 49        | 41        | 35        | 30        |      |      |
| 300       | 83.3  | V <sub>k</sub> | 7.6       | 3.4       | 1.9       | 1.2       |           |           |           | 1800      | 500.0  | V <sub>k</sub> |           |                |           | 7.4       | 5.1       | 3.8       | 2.9       |      |      |
|           |       | X              | 1.5       | 1.0       | 0.7       | 0.6       |           |           |           |           |        |                | X         |                | 3.6       | 3.0       | 2.6       | 2.2       |           |      |      |
|           |       | P <sub>t</sub> | 40.9      | 8.2       | 2.6       | 1.1       |           |           |           |           |        |                |           | P <sub>t</sub> |           | 38        | 18.3      | 9.9       | 5.8       |      |      |
|           |       | NR             | 45        | 28        | 16        | 7         |           |           |           |           |        |                |           | NR             |           | 52        | 44        | 38        | 33        |      |      |
| 350       | 97.2  | V <sub>k</sub> | 8.9       | 4.0       | 2.2       | 1.4       | 1.0       |           |           | 2000      | 555.6  | V <sub>k</sub> |           |                |           |           | 5.7       | 4.2       | 3.2       |      |      |
|           |       | X              | 1.7       | 1.2       | 0.9       | 0.7       | 0.6       |           |           |           |        |                | X         |                |           |           | 3.3       | 2.9       | 2.5       |      |      |
|           |       | P <sub>t</sub> | 55.7      | 11.1      | 3.5       | 1.4       | 0.7       |           |           |           |        |                |           | P <sub>t</sub> |           |           |           | 22.6      | 12.2      | 7.1  |      |
|           |       | NR             | 49        | 32        | 20        | 11        | -         |           |           |           |        |                |           | NR             |           |           |           | 47        | 41        | 35   |      |
| 400       | 111.1 | V <sub>k</sub> |           | 4.6       | 2.6       | 1.6       | 1.1       |           |           | 2500      | 694.4  | V <sub>k</sub> |           |                |           |           |           | 7.1       | 5.2       | 4.0  |      |
|           |       | X              |           | 1.3       | 1.0       | 0.8       | 0.7       |           |           |           |        |                | X         |                |           |           | 4.2       | 3.6       | 3.1       |      |      |
|           |       | P <sub>t</sub> |           | 14.5      | 4.6       | 1.9       | 0.9       |           |           |           |        |                |           | P <sub>t</sub> |           |           |           | 35.3      | 19.1      | 11.2 |      |
|           |       | NR             |           | 35        | 24        | 15        | 7         |           |           |           |        |                |           | NR             |           |           |           | 52        | 46        | 41   |      |
| 450       | 125.0 | V <sub>k</sub> |           | 5.1       | 2.9       | 1.8       | 1.3       |           |           | 3000      | 833.3  | V <sub>k</sub> |           |                |           |           |           |           | 6.3       | 4.8  |      |
|           |       | X              |           | 1.5       | 1.1       | 0.9       | 0.7       |           |           |           |        |                | X         |                |           |           |           |           | 4.3       | 3.7  |      |
|           |       | P <sub>t</sub> |           | 18.4      | 5.8       | 2.4       | 1.1       |           |           |           |        |                |           | P <sub>t</sub> |           |           |           |           |           | 27.4 | 16.1 |
|           |       | NR             |           | 38        | 27        | 17        | 10        |           |           |           |        |                |           | NR             |           |           |           |           |           | 51   | 45   |
| 500       | 138.9 | V <sub>k</sub> |           | 5.7       | 3.2       | 2.0       | 1.4       |           |           | 3500      | 972.2  | V <sub>k</sub> |           |                |           |           |           |           | 7.3       | 5.6  |      |
|           |       | X              |           | 1.7       | 1.2       | 1.0       | 0.8       |           |           |           |        |                | X         |                |           |           |           |           | 5         | 4.4  |      |
|           |       | P <sub>t</sub> |           | 22.7      | 7.1       | 2.9       | 1.4       |           |           |           |        |                |           | P <sub>t</sub> |           |           |           |           |           | 37.3 | 21.9 |
|           |       | NR             |           | 41        | 29        | 20        | 13        |           |           |           |        |                |           | NR             |           |           |           |           |           | 54   | 49   |
| 600       | 166.7 | V <sub>k</sub> |           | 6.8       | 3.8       | 2.5       | 1.7       | 1.3       |           | 4000      | 1111.1 | V <sub>k</sub> |           |                |           |           |           |           |           | 8.3  | 6.4  |
|           |       | X              |           | 2.0       | 1.5       | 1.2       | 1.0       | 0.9       |           |           |        |                | X         |                |           |           |           |           | 5.7       | 5.0  |      |
|           |       | P <sub>t</sub> |           | 32.7      | 10.3      | 4.2       | 2.0       | 1.1       |           |           |        |                |           | P <sub>t</sub> |           |           |           |           |           | 48.8 | 28.6 |
|           |       | NR             |           | 45        | 34        | 25        | 17        | 11        |           |           |        |                |           | NR             |           |           |           |           |           | 58   | 52   |

**Symbols:**

A<sub>k</sub> - Effective area

V<sub>k</sub> - Effective velocity in m/s

X - Throw in metres correspond to a terminal velocity in occupied zone of 0.25m/s

Pressure (P<sub>t</sub>) - All pressures are in Pa (N/m²)

NR - Noise level index in dB based on a room absorption and one diffuser

## Bevelled Edge 4 Way With Fixing Clips

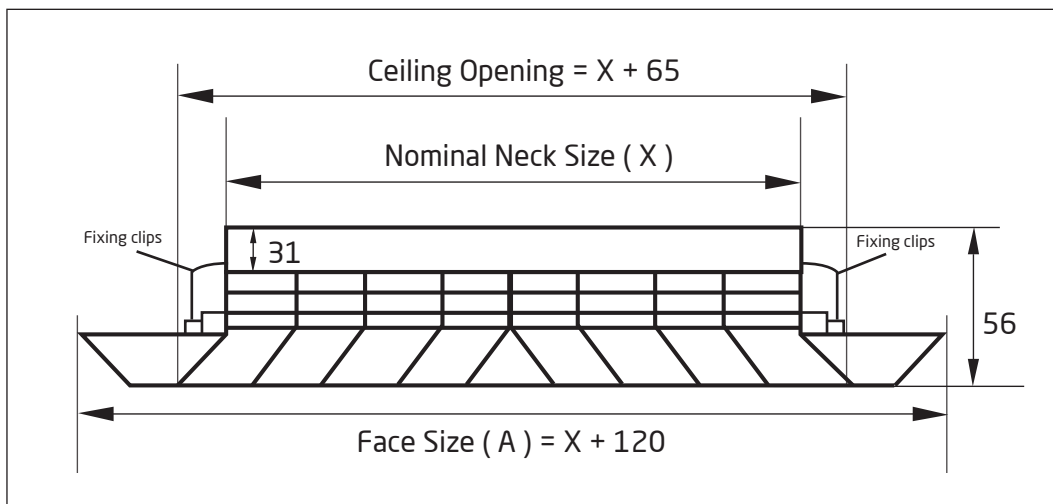

| Nominal Neck Metric ( X ) | Face Size ( A ) |
|---------------------------|-----------------|
| 150 x 150 mm              | 270 x 270 mm    |
| 225 x 225 mm              | 345 x 345 mm    |
| 300 x 300 mm              | 420 x 420 mm    |
| 375 x 375 mm              | 495 x 495 mm    |
| 450 x 450 mm              | 570 x 570 mm    |
| 525 x 525 mm              | 645 x 645 mm    |
| 600 x 600 mm              | 720 x 720 mm    |

\* Grilles are powder coated white as standard

\* The first number is for horizontal dimension and the second number is for vertical dimension

# Quick Selection Table

| Flow rate |       | Dim            | 150 x 150 | 225 x 225 | 300 x 300 | 375 x 375 | 450 x 450 | 525 x 525 | 600 x 600 | Flow rate |       | Dim            | 150 x 150      | 225 x 225 | 300 x 300 | 375 x 375 | 450 x 450 | 525 x 525 | 600 x 600 |     |  |
|-----------|-------|----------------|-----------|-----------|-----------|-----------|-----------|-----------|-----------|-----------|-------|----------------|----------------|-----------|-----------|-----------|-----------|-----------|-----------|-----|--|
| (m³/h)    | (l/s) | A <sub>k</sub> | 0.0096    | 0.0215    | 0.0383    | 0.0598    | 0.0863    | 0.1174    | 0.1534    | (m³/h)    | (l/s) | A <sub>k</sub> | 0.0096         | 0.0215    | 0.0383    | 0.0598    | 0.0863    | 0.1174    | 0.1534    |     |  |
| 50        | 13.9  | V <sub>k</sub> | 1.4       |           |           |           |           |           |           | 350       | 97.2  | V <sub>k</sub> |                | 4.5       | 2.5       | 1.6       | 1.1       | 0.8       |           |     |  |
|           |       | X              | 0.9       |           |           |           |           |           |           |           |       | X              |                | 4.1       | 3.1       | 2.5       | 2.0       | 1.8       |           |     |  |
|           |       | P <sub>t</sub> | 1.5       |           |           |           |           |           |           |           |       |                | P <sub>t</sub> |           | 14.3      | 4.5       | 1.9       | 0.9       | 0.5       |     |  |
|           |       | NR             | -         |           |           |           |           |           |           |           |       |                | NR             |           | 36        | 24        | 15        | 7         | -         |     |  |
| 60        | 16.7  | V <sub>k</sub> | 1.7       |           |           |           |           |           |           | 400       | 111.1 | V <sub>k</sub> |                | 5.2       | 2.9       | 1.9       | 1.3       | 0.9       |           |     |  |
|           |       | X              | 1.1       |           |           |           |           |           |           |           |       | X              |                | 4.7       | 3.5       | 2.8       | 2.3       | 2.0       |           |     |  |
|           |       | P <sub>t</sub> | 2.1       |           |           |           |           |           |           |           |       |                | P <sub>t</sub> |           | 18.7      | 5.9       | 2.4       | 1.2       | 0.6       |     |  |
|           |       | NR             | 9         |           |           |           |           |           |           |           |       |                | NR             |           | 39        | 27        | 18        | 10        | -         |     |  |
| 70        | 19.4  | V <sub>k</sub> | 2.0       | 0.9       |           |           |           |           |           | 500       | 138.9 | V <sub>k</sub> |                | 6.5       | 3.6       | 2.3       | 1.6       | 1.2       | 0.9       |     |  |
|           |       | X              | 1.2       | 0.8       |           |           |           |           |           |           |       | X              |                | 5.8       | 4.4       | 3.5       | 2.9       | 2.5       | 2.2       |     |  |
|           |       | P <sub>t</sub> | 2.9       | 0.6       |           |           |           |           |           |           |       |                | P <sub>t</sub> |           | 29.2      | 9.2       | 3.8       | 1.8       | 1.0       | 0.6 |  |
|           |       | NR             | 13        | -         |           |           |           |           |           |           |       |                | NR             |           | 45        | 33        | 23        | 16        | 9         | -   |  |
| 80        | 22.2  | V <sub>k</sub> | 2.3       | 1.0       |           |           |           |           |           | 600       | 166.7 | V <sub>k</sub> |                |           | 4.4       | 2.8       | 1.9       | 1.4       | 1.1       |     |  |
|           |       | X              | 1.4       | 0.9       |           |           |           |           |           |           |       | X              |                |           | 5.3       | 4.2       | 3.5       | 3.0       | 2.6       |     |  |
|           |       | P <sub>t</sub> | 3.8       | 0.7       |           |           |           |           |           |           |       |                | P <sub>t</sub> |           |           | 13.3      | 5.4       | 2.6       | 1.4       | 0.8 |  |
|           |       | NR             | 16        | -         |           |           |           |           |           |           |       |                | NR             |           |           | 37        | 28        | 20        | 14        | 8   |  |
| 90        | 25.0  | V <sub>k</sub> | 2.6       | 1.2       |           |           |           |           |           | 700       | 194.4 | V <sub>k</sub> |                |           | 5.1       | 3.3       | 2.3       | 1.7       | 1.3       |     |  |
|           |       | X              | 1.6       | 1.1       |           |           |           |           |           |           |       | X              |                |           | 6.1       | 4.9       | 4.1       | 3.5       | 3.1       |     |  |
|           |       | P <sub>t</sub> | 4.7       | 0.9       |           |           |           |           |           |           |       |                | P <sub>t</sub> |           |           | 18.0      | 7.4       | 3.6       | 1.9       | 1.1 |  |
|           |       | NR             | 19        | -         |           |           |           |           |           |           |       |                | NR             |           |           | 41        | 32        | 24        | 18        | 12  |  |
| 100       | 27.8  | V <sub>k</sub> | 2.9       | 1.3       |           |           |           |           |           | 800       | 222.2 | V <sub>k</sub> |                |           | 5.8       | 3.7       | 2.6       | 1.9       | 1.4       |     |  |
|           |       | X              | 1.8       | 1.2       |           |           |           |           |           |           |       | X              |                |           | 7.0       | 5.6       | 4.7       | 4.0       | 3.5       |     |  |
|           |       | P <sub>t</sub> | 5.9       | 1.2       |           |           |           |           |           |           |       |                | P <sub>t</sub> |           |           | 23.6      | 9.7       | 4.6       | 2.5       | 1.5 |  |
|           |       | NR             | 22        | 5         |           |           |           |           |           |           |       |                | NR             |           |           | 44        | 35        | 27        | 21        | 15  |  |
| 120       | 33.3  | V <sub>k</sub> | 3.5       | 1.6       | 0.9       |           |           |           |           | 900       | 250.0 | V <sub>k</sub> |                |           | 6.5       | 4.2       | 2.9       | 2.1       | 1.6       |     |  |
|           |       | X              | 2.1       | 1.4       | 1.1       |           |           |           |           |           |       | X              |                |           | 7.9       | 6.3       | 5.3       | 4.5       | 3.9       |     |  |
|           |       | P <sub>t</sub> | 8.4       | 1.7       | 0.5       |           |           |           |           |           |       |                | P <sub>t</sub> |           |           | 29.8      | 12.2      | 5.9       | 3.2       | 1.9 |  |
|           |       | NR             | 26        | 9         | -         |           |           |           |           |           |       |                | NR             |           |           | 47        | 38        | 30        | 24        | 18  |  |
| 140       | 38.9  | V <sub>k</sub> | 4.1       | 1.8       | 1.0       |           |           |           |           | 1000      | 277.8 | V <sub>k</sub> |                |           |           | 4.6       | 3.2       | 2.4       | 1.8       |     |  |
|           |       | X              | 2.5       | 1.6       | 1.2       |           |           |           |           |           |       | X              |                |           | 7.0       | 5.8       | 5.0       | 4.4       |           |     |  |
|           |       | P <sub>t</sub> | 11.5      | 2.3       | 0.7       |           |           |           |           |           |       |                | P <sub>t</sub> |           |           | 15.1      | 7.3       | 3.9       | 2.3       |     |  |
|           |       | NR             | 30        | 13        | -         |           |           |           |           |           |       |                | NR             |           |           | 41        | 33        | 26        | 21        |     |  |
| 160       | 44.4  | V <sub>k</sub> | 4.6       | 2.1       | 1.2       |           |           |           |           | 1200      | 333.3 | V <sub>k</sub> |                |           |           | 5.6       | 3.9       | 2.8       | 2.2       |     |  |
|           |       | X              | 2.8       | 1.9       | 1.4       |           |           |           |           |           |       | X              |                |           | 8.4       | 7.0       | 6.0       | 5.3       |           |     |  |
|           |       | P <sub>t</sub> | 15.0      | 3.0       | 0.9       |           |           |           |           |           |       |                | P <sub>t</sub> |           |           | 21.7      | 10.4      | 5.6       | 3.3       |     |  |
|           |       | NR             | 33        | 16        | -         |           |           |           |           |           |       |                | NR             |           |           | 45        | 37        | 31        | 25        |     |  |
| 180       | 50.0  | V <sub>k</sub> | 5.2       | 2.3       | 1.3       |           |           |           |           | 1400      | 388.9 | V <sub>k</sub> |                |           |           | 6.5       | 4.5       | 3.3       | 2.5       |     |  |
|           |       | X              | 3.2       | 2.1       | 1.6       |           |           |           |           |           |       | X              |                |           | 9.8       | 8.2       | 7.0       | 6.1       |           |     |  |
|           |       | P <sub>t</sub> | 19.0      | 3.8       | 1.2       |           |           |           |           |           |       |                | P <sub>t</sub> |           |           | 29.6      | 14.2      | 7.7       | 4.5       |     |  |
|           |       | NR             | 36        | 19        | 7         |           |           |           |           |           |       |                | NR             |           |           | 49        | 41        | 35        | 29        |     |  |
| 200       | 55.6  | V <sub>k</sub> | 5.8       | 2.6       | 1.5       | 0.9       |           |           |           | 1600      | 444.4 | V <sub>k</sub> |                |           |           |           | 5.1       | 3.8       | 2.9       |     |  |
|           |       | X              | 3.5       | 2.3       | 1.8       | 1.4       |           |           |           |           |       | X              |                |           |           | 9.3       | 8.0       | 7.0       |           |     |  |
|           |       | P <sub>t</sub> | 23.4      | 4.7       | 1.5       | 0.6       |           |           |           |           |       |                | P <sub>t</sub> |           |           |           | 18.6      | 10.0      | 5.9       |     |  |
|           |       | NR             | 39        | 22        | 10        | -         |           |           |           |           |       |                | NR             |           |           |           | 44        | 38        | 33        |     |  |
| 250       | 69.4  | V <sub>k</sub> | 7.2       | 3.2       | 1.8       | 1.2       | 0.8       |           |           | 1800      | 500.0 | V <sub>k</sub> |                |           |           |           | 5.8       | 4.3       | 3.3       |     |  |
|           |       | X              | 4.4       | 2.9       | 2.2       | 1.8       | 1.5       |           |           |           |       | X              |                |           |           | 10.5      | 9.0       | 7.9       |           |     |  |
|           |       | P <sub>t</sub> | 36.6      | 7.3       | 2.3       | 0.9       | 0.5       |           |           |           |       |                | P <sub>t</sub> |           |           |           | 23.5      | 12.7      | 7.4       |     |  |
|           |       | NR             | 44        | 28        | 15        | 6         | -         |           |           |           |       |                | NR             |           |           |           | 47        | 41        | 35        |     |  |
| 300       | 83.3  | V <sub>k</sub> |           | 3.9       | 2.2       | 1.4       | 1.0       |           |           | 2000      | 555.6 | V <sub>k</sub> |                |           |           |           | 6.4       | 4.7       | 3.6       |     |  |
|           |       | X              |           | 3.5       | 2.6       | 2.1       | 1.8       |           |           |           |       | X              |                |           |           | 11.7      | 10.0      | 8.8       |           |     |  |
|           |       | P <sub>t</sub> |           | 10.5      | 3.3       | 1.4       | 0.7       |           |           |           |       |                | P <sub>t</sub> |           |           |           | 29.0      | 15.7      | 9.2       |     |  |
|           |       | NR             |           | 32        | 20        | 11        | -         |           |           |           |       |                | NR             |           |           |           | 50        | 44        | 38        |     |  |

**Symbols:**

A<sub>k</sub> - Effective area

V<sub>k</sub> - Effective velocity in m/s

X - Throw in metres correspond to a terminal velocity in occupied zone of 0.25m/s

Pressure (P<sub>t</sub>) - All pressures are in Pa (N/m²)

NR - Noise level index in dB based on a room absorption and one diffuser

## Quick Selection Table

| Flow rate |       | Dim            | 150 x 150 | 225 x 225 | 300 x 300 | 375 x 375 | 450 x 450 | 525 x 525 | 600 x 160 | Flow rate |        | Dim            | 150 x 150      | 225 x 225 | 300 x 300 | 375 x 375 | 450 x 450 | 525 x 525 | 600 x 160 |      |
|-----------|-------|----------------|-----------|-----------|-----------|-----------|-----------|-----------|-----------|-----------|--------|----------------|----------------|-----------|-----------|-----------|-----------|-----------|-----------|------|
| (m³/h)    | (l/s) | A <sub>k</sub> | 0.0109    | 0.0244    | 0.0435    | 0.0679    | 0.0978    | 0.1331    | 0.1739    | (m³/h)    | (l/s)  | A <sub>k</sub> | 0.0109         | 0.0244    | 0.0435    | 0.0679    | 0.0978    | 0.1331    | 0.1739    |      |
| 100       | 27.8  | V <sub>k</sub> | 2.5       | 1.1       |           |           |           |           |           | 700       | 194.4  | V <sub>k</sub> |                | 8.0       | 4.5       | 2.9       | 2.0       | 1.5       | 1.1       |      |
|           |       | X              | 0.5       | 0.3       |           |           |           |           |           |           |        | X              |                | 2.3       | 1.7       | 1.4       | 1.2       | 1.0       | 0.9       |      |
|           |       | P <sub>t</sub> | 4.5       | 0.9       |           |           |           |           |           |           |        |                | P <sub>t</sub> |           | 44.5      | 14.0      | 5.7       | 2.8       | 1.5       | 0.9  |
|           |       | NR             | 18        | -         |           |           |           |           |           |           |        |                | NR             |           | 49        | 37        | 28        | 21        | 15        | 9    |
| 120       | 33.3  | V <sub>k</sub> | 3.1       | 1.4       |           |           |           |           |           | 800       | 222.2  | V <sub>k</sub> |                |           | 5.1       | 3.3       | 2.3       | 1.7       | 1.3       |      |
|           |       | X              | 0.6       | 0.4       |           |           |           |           |           |           |        | X              |                |           | 2.0       | 1.6       | 1.3       | 1.1       | 1.0       |      |
|           |       | P <sub>t</sub> | 6.5       | 1.3       |           |           |           |           |           |           |        |                | P <sub>t</sub> |           |           | 18.3      | 7.5       | 3.6       | 2.0       | 1.1  |
|           |       | NR             | 22        | 6         |           |           |           |           |           |           |        |                | NR             |           |           | 41        | 32        | 24        | 18        | 12   |
| 140       | 38.9  | V <sub>k</sub> | 3.6       | 1.6       |           |           |           |           |           | 900       | 250.0  | V <sub>k</sub> |                |           | 5.7       | 3.7       | 2.6       | 1.9       | 1.4       |      |
|           |       | X              | 0.7       | 0.5       |           |           |           |           |           |           |        | X              |                |           | 2.2       | 1.8       | 1.5       | 1.3       | 1.1       |      |
|           |       | P <sub>t</sub> | 8.9       | 1.8       |           |           |           |           |           |           |        |                | P <sub>t</sub> |           |           | 23.1      | 9.5       | 4.6       | 2.5       | 1.4  |
|           |       | NR             | 26        | 9         |           |           |           |           |           |           |        |                | NR             |           |           | 44        | 35        | 27        | 21        | 15   |
| 160       | 44.4  | V <sub>k</sub> | 4.1       | 1.8       | 1.0       |           |           |           |           | 1000      | 277.8  | V <sub>k</sub> |                |           | 6.4       | 4.1       | 2.8       | 2.1       | 1.6       |      |
|           |       | X              | 0.8       | 0.5       | 0.4       |           |           |           |           |           |        | X              |                |           | 2.5       | 2.0       | 1.7       | 1.4       | 1.2       |      |
|           |       | P <sub>t</sub> | 11.6      | 2.3       | 0.7       |           |           |           |           |           |        |                | P <sub>t</sub> |           |           | 28.5      | 11.7      | 5.6       | 3.0       | 1.8  |
|           |       | NR             | 29        | 13        | -         |           |           |           |           |           |        |                | NR             |           |           | 46        | 37        | 30        | 23        | 18   |
| 180       | 50.0  | V <sub>k</sub> | 4.6       | 2.0       | 1.1       |           |           |           |           | 1200      | 333.3  | V <sub>k</sub> |                |           | 7.7       | 4.9       | 3.4       | 2.5       | 1.9       |      |
|           |       | X              | 0.9       | 0.6       | 0.4       |           |           |           |           |           |        | X              |                |           | 3.0       | 2.4       | 2.0       | 1.7       | 1.5       |      |
|           |       | P <sub>t</sub> | 14.7      | 2.9       | 0.9       |           |           |           |           |           |        |                | P <sub>t</sub> |           |           | 41.1      | 16.9      | 8.1       | 4.4       | 2.6  |
|           |       | NR             | 32        | 16        | -         |           |           |           |           |           |        |                | NR             |           |           | 51        | 42        | 34        | 28        | 23   |
| 200       | 55.6  | V <sub>k</sub> | 5.1       | 2.3       | 1.3       |           |           |           |           | 1400      | 388.9  | V <sub>k</sub> |                |           |           | 5.7       | 4.0       | 2.9       | 2.2       |      |
|           |       | X              | 1.0       | 0.7       | 0.5       |           |           |           |           |           |        | X              |                |           |           | 2.8       | 2.3       | 2.0       | 1.7       |      |
|           |       | P <sub>t</sub> | 18.2      | 3.6       | 1.1       |           |           |           |           |           |        |                | P <sub>t</sub> |           |           |           | 23        | 11.1      | 6.0       | 3.5  |
|           |       | NR             | 35        | 18        | 6         |           |           |           |           |           |        |                | NR             |           |           |           | 46        | 38        | 32        | 26   |
| 250       | 69.4  | V <sub>k</sub> | 6.4       | 2.8       | 1.6       | 1.0       |           |           |           | 1600      | 444.4  | V <sub>k</sub> |                |           |           |           | 6.5       | 4.5       | 3.3       | 2.6  |
|           |       | X              | 1.2       | 0.8       | 0.6       | 0.5       |           |           |           |           |        | X              |                |           |           | 3.2       | 2.7       | 2.3       | 2.0       |      |
|           |       | P <sub>t</sub> | 28.4      | 5.7       | 1.8       | 0.7       |           |           |           |           |        |                | P <sub>t</sub> |           |           |           | 30        | 14.5      | 7.8       | 4.6  |
|           |       | NR             | 40        | 24        | 12        | -         |           |           |           |           |        |                | NR             |           |           |           | 49        | 41        | 35        | 30   |
| 300       | 83.3  | V <sub>k</sub> | 7.6       | 3.4       | 1.9       | 1.2       |           |           |           | 1800      | 500.0  | V <sub>k</sub> |                |           |           |           | 7.4       | 5.1       | 3.8       | 2.9  |
|           |       | X              | 1.5       | 1.0       | 0.7       | 0.6       |           |           |           |           |        | X              |                |           |           | 3.6       | 3.0       | 2.6       | 2.2       |      |
|           |       | P <sub>t</sub> | 40.9      | 8.2       | 2.6       | 1.1       |           |           |           |           |        |                | P <sub>t</sub> |           |           |           | 38        | 18.3      | 9.9       | 5.8  |
|           |       | NR             | 45        | 28        | 16        | 7         |           |           |           |           |        |                | NR             |           |           |           | 52        | 44        | 38        | 33   |
| 350       | 97.2  | V <sub>k</sub> | 8.9       | 4.0       | 2.2       | 1.4       | 1.0       |           |           | 2000      | 555.6  | V <sub>k</sub> |                |           |           |           |           | 5.7       | 4.2       | 3.2  |
|           |       | X              | 1.7       | 1.2       | 0.9       | 0.7       | 0.6       |           |           |           |        | X              |                |           |           |           | 3.3       | 2.9       | 2.5       |      |
|           |       | P <sub>t</sub> | 55.7      | 11.1      | 3.5       | 1.4       | 0.7       |           |           |           |        |                | P <sub>t</sub> |           |           |           |           | 22.6      | 12.2      | 7.1  |
|           |       | NR             | 49        | 32        | 20        | 11        | -         |           |           |           |        |                | NR             |           |           |           |           | 47        | 41        | 35   |
| 400       | 111.1 | V <sub>k</sub> |           | 4.6       | 2.6       | 1.6       | 1.1       |           |           | 2500      | 694.4  | V <sub>k</sub> |                |           |           |           |           | 7.1       | 5.2       | 4.0  |
|           |       | X              |           | 1.3       | 1.0       | 0.8       | 0.7       |           |           |           |        | X              |                |           |           |           | 4.2       | 3.6       | 3.1       |      |
|           |       | P <sub>t</sub> |           | 14.5      | 4.6       | 1.9       | 0.9       |           |           |           |        |                | P <sub>t</sub> |           |           |           |           | 35.3      | 19.1      | 11.2 |
|           |       | NR             |           | 35        | 24        | 15        | 7         |           |           |           |        |                | NR             |           |           |           |           | 52        | 46        | 41   |
| 450       | 125.0 | V <sub>k</sub> |           | 5.1       | 2.9       | 1.8       | 1.3       |           |           | 3000      | 833.3  | V <sub>k</sub> |                |           |           |           |           |           | 6.3       | 4.8  |
|           |       | X              |           | 1.5       | 1.1       | 0.9       | 0.7       |           |           |           |        | X              |                |           |           |           |           | 4.3       | 3.7       |      |
|           |       | P <sub>t</sub> |           | 18.4      | 5.8       | 2.4       | 1.1       |           |           |           |        |                | P <sub>t</sub> |           |           |           |           |           | 27.4      | 16.1 |
|           |       | NR             |           | 38        | 27        | 17        | 10        |           |           |           |        |                | NR             |           |           |           |           |           | 51        | 45   |
| 500       | 138.9 | V <sub>k</sub> |           | 5.7       | 3.2       | 2.0       | 1.4       |           |           | 3500      | 972.2  | V <sub>k</sub> |                |           |           |           |           |           | 7.3       | 5.6  |
|           |       | X              |           | 1.7       | 1.2       | 1.0       | 0.8       |           |           |           |        | X              |                |           |           |           |           | 5         | 4.4       |      |
|           |       | P <sub>t</sub> |           | 22.7      | 7.1       | 2.9       | 1.4       |           |           |           |        |                | P <sub>t</sub> |           |           |           |           |           | 37.3      | 21.9 |
|           |       | NR             |           | 41        | 29        | 20        | 13        |           |           |           |        |                | NR             |           |           |           |           |           | 54        | 49   |
| 600       | 166.7 | V <sub>k</sub> |           | 6.8       | 3.8       | 2.5       | 1.7       | 1.3       |           | 4000      | 1111.1 | V <sub>k</sub> |                |           |           |           |           |           | 8.3       | 6.4  |
|           |       | X              |           | 2.0       | 1.5       | 1.2       | 1.0       | 0.9       |           |           |        | X              |                |           |           |           |           | 5.7       | 5.0       |      |
|           |       | P <sub>t</sub> |           | 32.7      | 10.3      | 4.2       | 2.0       | 1.1       |           |           |        |                | P <sub>t</sub> |           |           |           |           |           | 48.8      | 28.6 |
|           |       | NR             |           | 45        | 34        | 25        | 17        | 11        |           |           |        |                | NR             |           |           |           |           |           | 58        | 52   |

Symbols:

A<sub>k</sub> - Effective area

V<sub>k</sub> - Effective velocity in m/s

X - Throw in metres correspond to a terminal velocity in occupied zone of 0.25m/s

Pressure (P<sub>t</sub>) - All pressures are in Pa (N/m²)

NR - Noise level index in dB based on a room absorption and one diffuser

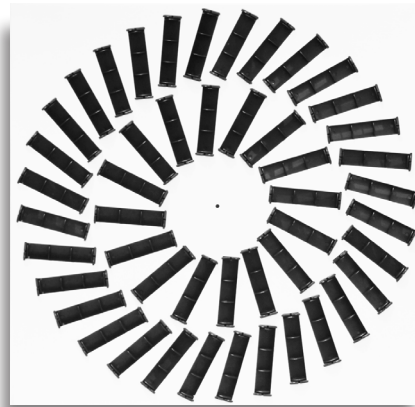
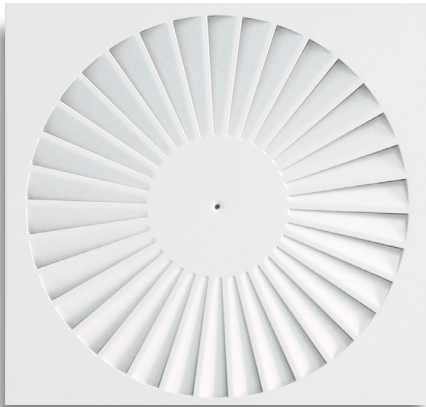

## Swirl Diffuser

### General Information:

Increasingly stringent requirements from the standpoint of technical features (higher supply flow rates and lower velocities in the occupant area) and aesthetics (smoother incorporation in the interior design) have generally made swirl diffusers a better choice for air diffusion.

The recommended mounting height is around 2.5 to 4.0 m for all models. All these units can be used in VAV systems, allowing the flow rate to be reduced up to 25% of the nominal air flow rate without producing uncomfortable air currents in the facility.

### Features:

- Powder coated white as standard
- A high quality diffuser to generate airflow according to the principle of turbulent mixed airflow
- Low sound power level and pressure loss
- Installation for prefabricated ceiling or surface mounted for closed false ceilings

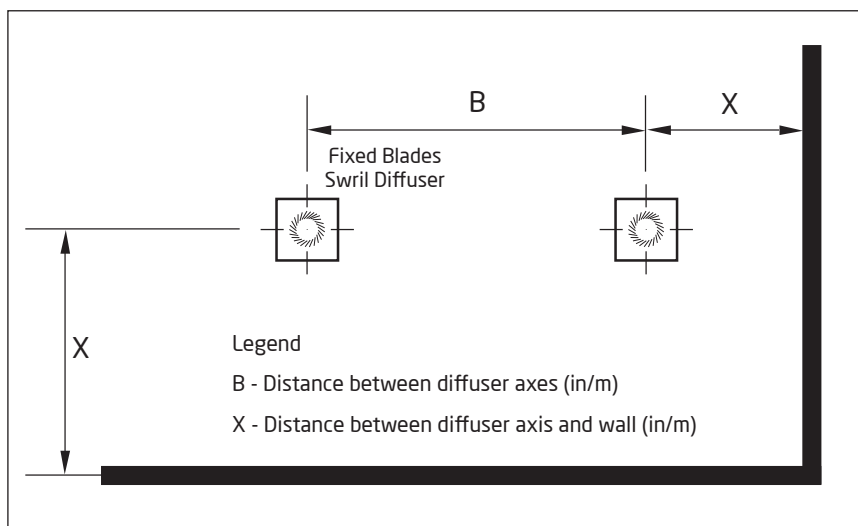

# Fixed Blade Swirl Diffuser

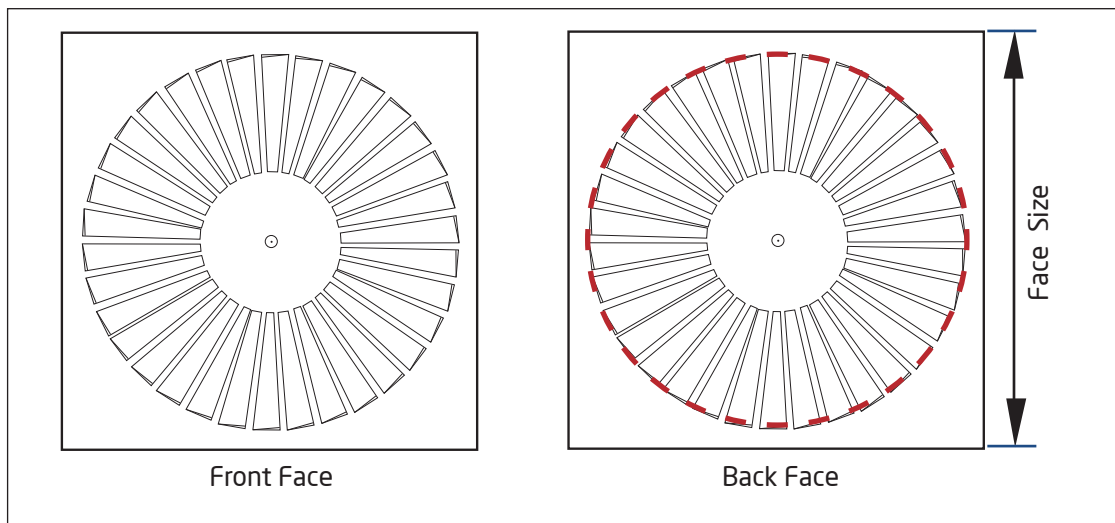
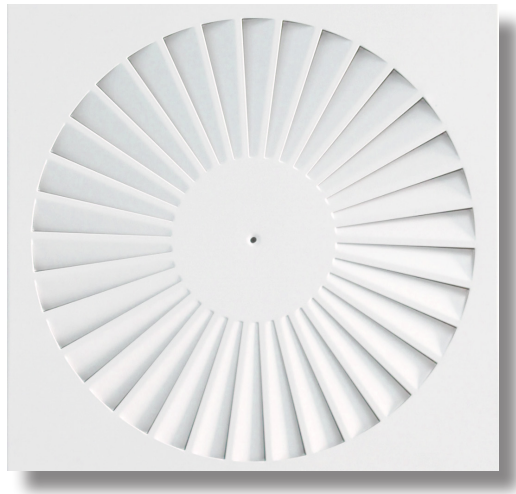

| Face Size ( A ) | No. of Blade |
|-----------------|--------------|
| 595 x 595 mm    | 34           |

\* Grilles are powder coated white as standard

\* The first number is for horizontal dimension and the second number is for vertical dimension

# Adjustable Blade Swirl Diffuser

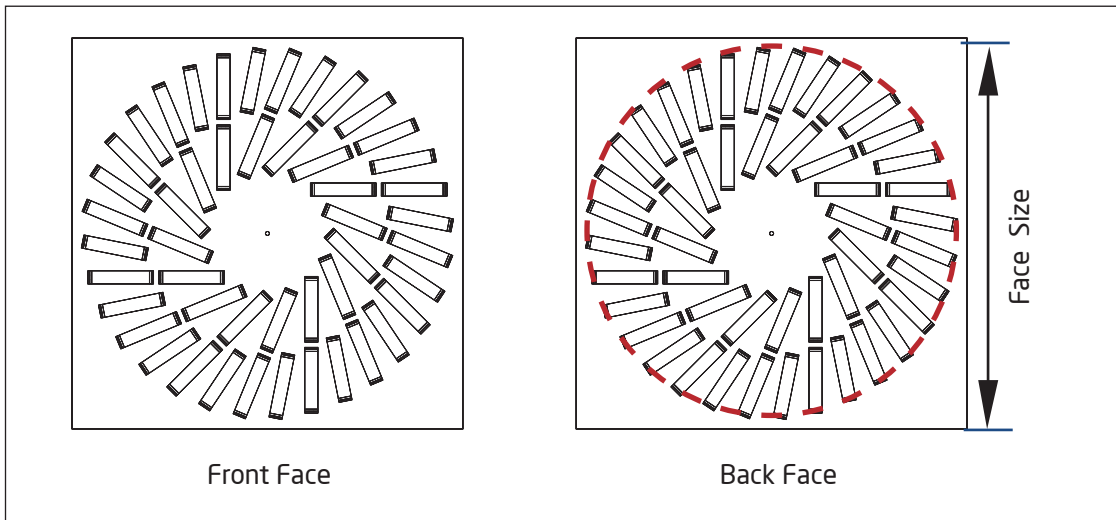
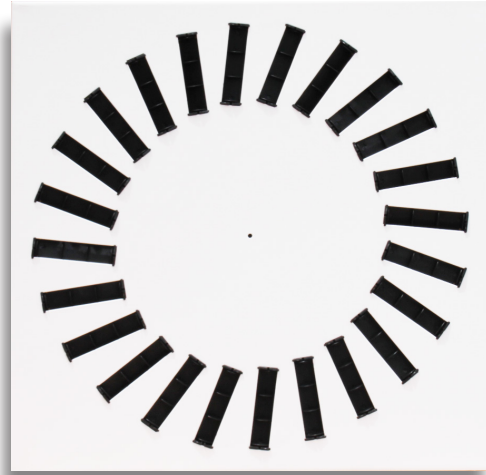
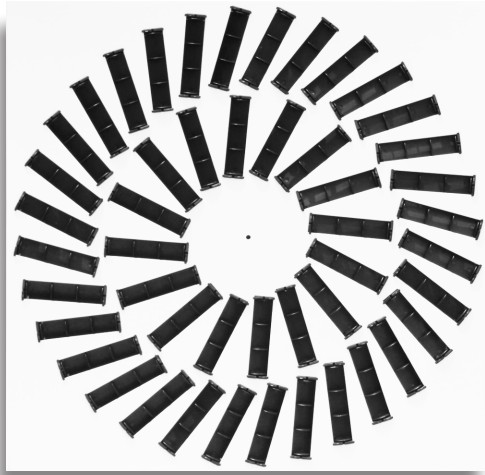

| Face Size ( A ) | No. of Blade |
|-----------------|--------------|
| 595 x 595 mm    | 16           |
| 595 x 595 mm    | 24           |
| 595 x 595 mm    | 48           |

\* Grilles are powder coated white as standard

\* The first number is for horizontal dimension and the second number is for vertical dimension

## Quick Selection Table - Air Stream Between Diffusers

| Flow rate           |       | No. of slots   | 16      |      |      | 24   |      |      | 32   |      |      | 36   |      |      | 40   |      |      | 48   |      |      |      |  |  |
|---------------------|-------|----------------|---------|------|------|------|------|------|------|------|------|------|------|------|------|------|------|------|------|------|------|--|--|
| (m <sup>3</sup> /h) | (l/s) | B              | 1.2     | 1.8  | 2.7  | 1.2  | 1.8  | 2.7  | 1.2  | 1.8  | 2.7  | 1.2  | 1.8  | 2.7  | 1.2  | 1.8  | 2.7  | 1.2  | 1.8  | 2.7  |      |  |  |
| 50                  | 13.9  | V <sub>z</sub> | H = 2.7 |      |      |      |      |      |      |      |      |      |      |      |      |      |      |      |      |      |      |  |  |
|                     |       |                | H = 3.2 |      |      |      |      |      |      |      |      |      |      |      |      |      |      |      |      |      |      |  |  |
|                     |       |                | H = 3.8 |      |      |      |      |      |      |      |      |      |      |      |      |      |      |      |      |      |      |  |  |
|                     |       | P <sub>t</sub> |         |      |      |      |      |      |      |      |      |      |      |      |      |      |      |      |      |      |      |  |  |
|                     |       | NR             |         |      |      |      |      |      |      |      |      |      |      |      |      |      |      |      |      |      |      |  |  |
| 150                 | 41.7  | V <sub>z</sub> | H = 2.7 | 0.09 | 0.12 | 0.08 |      |      |      |      |      |      |      |      |      |      |      |      |      |      |      |  |  |
|                     |       |                | H = 3.2 | 0.06 | 0.07 | 0.05 |      |      |      |      |      |      |      |      |      |      |      |      |      |      |      |  |  |
|                     |       |                | H = 3.8 | 0.04 | 0.05 | 0.05 |      |      |      |      |      |      |      |      |      |      |      |      |      |      |      |  |  |
|                     |       | P <sub>t</sub> | 4       | 4    | 4    |      |      |      |      |      |      |      |      |      |      |      |      |      |      |      |      |  |  |
|                     |       | NR             | < 15    | < 15 | < 15 |      |      |      |      |      |      |      |      |      |      |      |      |      |      |      |      |  |  |
| 250                 | 69.4  | V <sub>z</sub> | H = 2.7 | 0.15 | 0.19 | 0.13 | 0.11 | 0.14 | 0.11 |      |      |      |      |      |      |      |      |      |      |      |      |  |  |
|                     |       |                | H = 3.2 | 0.10 | 0.12 | 0.08 | 0.07 | 0.09 | 0.07 |      |      |      |      |      |      |      |      |      |      |      |      |  |  |
|                     |       |                | H = 3.8 | 0.07 | 0.08 | 0.06 | 0.05 | 0.06 | 0.05 |      |      |      |      |      |      |      |      |      |      |      |      |  |  |
|                     |       | P <sub>t</sub> | 12      | 12   | 12   | 4    | 4    | 4    |      |      |      |      |      |      |      |      |      |      |      |      |      |  |  |
|                     |       | NR             | 29      | 29   | 29   | < 15 | < 15 | < 15 |      |      |      |      |      |      |      |      |      |      |      |      |      |  |  |
| 350                 | 97.2  | V <sub>z</sub> | H = 2.7 | 0.21 | 0.27 | 0.19 | 0.16 | 0.19 | 0.15 | 0.15 | 0.17 | 0.13 | 0.13 | 0.16 | 0.11 | 0.13 | 0.14 | 0.11 |      |      |      |  |  |
|                     |       |                | H = 3.2 | 0.13 | 0.17 | 0.12 | 0.10 | 0.12 | 0.09 | 0.09 | 0.11 | 0.08 | 0.08 | 0.10 | 0.07 | 0.08 | 0.09 | 0.07 |      |      |      |  |  |
|                     |       |                | H = 3.8 | 0.09 | 0.12 | 0.08 | 0.07 | 0.08 | 0.07 | 0.06 | 0.08 | 0.06 | 0.06 | 0.07 | 0.05 | 0.06 | 0.06 | 0.05 |      |      |      |  |  |
|                     |       | P <sub>t</sub> | 24      | 24   | 24   | 7    | 7    | 7    | 6    | 6    | 6    | 5    | 5    | 5    | 3    | 3    | 3    |      |      |      |      |  |  |
|                     |       | NR             | 39      | 39   | 39   | 20   | 20   | 20   | 15   | 15   | 15   | < 15 | < 15 | < 15 | < 15 | < 15 | < 15 |      |      |      |      |  |  |
| 500                 | 138.9 | V <sub>z</sub> | H = 2.7 | 0.30 | 0.38 | 0.27 | 0.22 | 0.28 | 0.21 | 0.21 | 0.24 | 0.18 | 0.19 | 0.23 | 0.16 | 0.18 | 0.20 | 0.15 | 0.17 | 0.18 | 0.14 |  |  |
|                     |       |                | H = 3.2 | 0.19 | 0.24 | 0.17 | 0.14 | 0.17 | 0.14 | 0.13 | 0.15 | 0.11 | 0.12 | 0.14 | 0.10 | 0.11 | 0.13 | 0.10 | 0.11 | 0.11 | 0.09 |  |  |
|                     |       |                | H = 3.8 | 0.13 | 0.17 | 0.12 | 0.10 | 0.12 | 0.09 | 0.09 | 0.11 | 0.08 | 0.08 | 0.10 | 0.07 | 0.08 | 0.09 | 0.07 | 0.08 | 0.08 | 0.06 |  |  |
|                     |       | P <sub>t</sub> | 49      | 49   | 49   | 14   | 14   | 14   | 12   | 12   | 12   | 11   | 11   | 11   | 7    | 7    | 7    | 5    | 5    | 5    |      |  |  |
|                     |       | NR             | 50      | 50   | 50   | 30   | 30   | 30   | 26   | 26   | 26   | 25   | 25   | 25   | 18   | 18   | 18   | < 15 | < 15 | < 15 |      |  |  |
| 650                 | 180.6 | V <sub>z</sub> | H = 2.7 |      |      |      | 0.29 | 0.36 | 0.28 | 0.27 | 0.31 | 0.24 | 0.24 | 0.29 | 0.21 | 0.24 | 0.26 | 0.20 | 0.23 | 0.23 | 0.19 |  |  |
|                     |       |                | H = 3.2 |      |      |      | 0.18 | 0.23 | 0.18 | 0.17 | 0.20 | 0.15 | 0.15 | 0.18 | 0.13 | 0.15 | 0.16 | 0.13 | 0.14 | 0.15 | 0.12 |  |  |
|                     |       |                | H = 3.8 |      |      |      | 0.13 | 0.16 | 0.12 | 0.12 | 0.14 | 0.10 | 0.11 | 0.13 | 0.09 | 0.10 | 0.11 | 0.09 | 0.10 | 0.10 | 0.08 |  |  |
|                     |       | P <sub>t</sub> |         |      |      | 24   | 24   | 24   | 20   | 20   | 20   | 19   | 19   | 19   | 12   | 12   | 12   | 8    | 8    | 8    |      |  |  |
|                     |       | NR             |         |      |      | 38   | 38   | 38   | 34   | 34   | 34   | 32   | 32   | 32   | 26   | 26   | 26   | 21   | 21   | 21   |      |  |  |
| 800                 | 222.2 | V <sub>z</sub> | H = 2.7 |      |      |      | 0.36 | 0.44 | 0.34 | 0.34 | 0.38 | 0.29 | 0.30 | 0.36 | 0.26 | 0.29 | 0.32 | 0.25 | 0.28 | 0.29 | 0.23 |  |  |
|                     |       |                | H = 3.2 |      |      |      | 0.23 | 0.28 | 0.22 | 0.21 | 0.24 | 0.18 | 0.19 | 0.22 | 0.16 | 0.18 | 0.20 | 0.16 | 0.17 | 0.18 | 0.14 |  |  |
|                     |       |                | H = 3.8 |      |      |      | 0.16 | 0.19 | 0.15 | 0.15 | 0.17 | 0.13 | 0.13 | 0.16 | 0.11 | 0.13 | 0.14 | 0.11 | 0.12 | 0.12 | 0.10 |  |  |
|                     |       | P <sub>t</sub> |         |      |      | 36   | 36   | 36   | 30   | 30   | 30   | 28   | 28   | 28   | 18   | 18   | 18   | 12   | 12   | 12   |      |  |  |
|                     |       | NR             |         |      |      | 45   | 45   | 45   | 40   | 40   | 40   | 39   | 39   | 39   | 32   | 32   | 32   | 27   | 27   | 27   |      |  |  |
| 1000                | 277.8 | V <sub>z</sub> | H = 2.7 |      |      |      |      |      |      | 0.42 | 0.48 | 0.36 | 0.38 | 0.44 | 0.33 | 0.36 | 0.40 | 0.31 | 0.35 | 0.36 | 0.29 |  |  |
|                     |       |                | H = 3.2 |      |      |      |      |      |      | 0.27 | 0.30 | 0.23 | 0.24 | 0.28 | 0.21 | 0.23 | 0.25 | 0.19 | 0.22 | 0.22 | 0.18 |  |  |
|                     |       |                | H = 3.8 |      |      |      |      |      |      | 0.19 | 0.21 | 0.16 | 0.16 | 0.19 | 0.14 | 0.16 | 0.17 | 0.13 | 0.15 | 0.16 | 0.13 |  |  |
|                     |       | P <sub>t</sub> |         |      |      |      |      |      | 46   | 46   | 46   | 44   | 44   | 44   | 29   | 29   | 29   | 19   | 19   | 19   |      |  |  |
|                     |       | NR             |         |      |      |      |      |      | 47   | 47   | 47   | 45   | 45   | 45   | 39   | 39   | 39   | 34   | 34   | 34   |      |  |  |
| 1250                | 347.2 | V <sub>z</sub> | H = 2.7 |      |      |      |      |      |      |      |      |      |      |      |      | 0.45 | 0.50 | 0.39 | 0.43 | 0.45 | 0.36 |  |  |
|                     |       |                | H = 3.2 |      |      |      |      |      |      |      |      |      |      |      |      | 0.29 | 0.31 | 0.24 | 0.27 | 0.28 | 0.23 |  |  |
|                     |       |                | H = 3.8 |      |      |      |      |      |      |      |      |      |      |      |      | 0.20 | 0.22 | 0.17 | 0.19 | 0.19 | 0.16 |  |  |
|                     |       | P <sub>t</sub> |         |      |      |      |      |      |      |      |      |      |      |      |      | 45   | 45   | 45   | 30   | 30   | 30   |  |  |
|                     |       | NR             |         |      |      |      |      |      |      |      |      |      |      |      | 46   | 46   | 46   | 40   | 40   | 40   |      |  |  |
| 1600                | 444.4 | V <sub>z</sub> | H = 2.7 |      |      |      |      |      |      |      |      |      |      |      |      |      |      | 0.55 | 0.57 | 0.46 |      |  |  |
|                     |       |                | H = 3.2 |      |      |      |      |      |      |      |      |      |      |      |      |      |      | 0.35 | 0.36 | 0.29 |      |  |  |
|                     |       |                | H = 3.8 |      |      |      |      |      |      |      |      |      |      |      |      |      |      | 0.24 | 0.25 | 0.20 |      |  |  |
|                     |       | P <sub>t</sub> |         |      |      |      |      |      |      |      |      |      |      |      |      |      |      | 48   | 48   | 48   |      |  |  |
|                     |       | NR             |         |      |      |      |      |      |      |      |      |      |      |      |      |      | 48   | 48   | 48   |      |      |  |  |

### Symbols:

B - Distance between diffusers

H - Room height (m)

V<sub>z</sub> - Air flow velocity in occupied area (m)

Pressure (P<sub>t</sub>) - All pressures are in Pa (N/m<sup>2</sup>)

NR - Noise level index in dB based on a room absorption and one diffuser

**Quick Selection Table - Air Stream Toward the Wall**

| Flow rate           |       | No. of slots   | 16      |      |      | 20   |      |      | 24   |      |      | 32   |      |      | 36   |      |      | 40   |      |      | 48   |      |      |      |      |
|---------------------|-------|----------------|---------|------|------|------|------|------|------|------|------|------|------|------|------|------|------|------|------|------|------|------|------|------|------|
| (m <sup>3</sup> /h) | (l/s) | B              | 1.2     | 1.8  | 2.7  | 1.2  | 1.8  | 2.7  | 1.2  | 1.8  | 2.7  | 1.2  | 1.8  | 2.7  | 1.2  | 1.8  | 2.7  | 1.2  | 1.8  | 2.7  | 1.2  | 1.8  | 2.7  |      |      |
| 50                  | 13.9  | V <sub>z</sub> | H = 2.7 |      |      |      |      |      |      |      |      |      |      |      |      |      |      |      |      |      |      |      |      |      |      |
|                     |       |                | H = 3.2 |      |      |      |      |      |      |      |      |      |      |      |      |      |      |      |      |      |      |      |      |      |      |
|                     |       |                | H = 3.8 |      |      |      |      |      |      |      |      |      |      |      |      |      |      |      |      |      |      |      |      |      |      |
|                     |       | P <sub>t</sub> |         |      |      |      |      |      |      |      |      |      |      |      |      |      |      |      |      |      |      |      |      |      |      |
|                     |       | NR             |         |      |      |      |      |      |      |      |      |      |      |      |      |      |      |      |      |      |      |      |      |      |      |
| 150                 | 41.7  | V <sub>z</sub> | H = 2.7 | 0.18 | 0.11 | 0.09 | 0.14 | 0.09 | 0.07 |      |      |      |      |      |      |      |      |      |      |      |      |      |      |      |      |
|                     |       |                | H = 3.2 | 0.14 | 0.09 | 0.08 | 0.11 | 0.07 | 0.06 |      |      |      |      |      |      |      |      |      |      |      |      |      |      |      |      |
|                     |       |                | H = 3.8 | 0.11 | 0.08 | 0.07 | 0.08 | 0.06 | 0.05 |      |      |      |      |      |      |      |      |      |      |      |      |      |      |      |      |
|                     |       | P <sub>t</sub> | 4       | 4    | 4    | 3    | 3    | 3    |      |      |      |      |      |      |      |      |      |      |      |      |      |      |      |      |      |
|                     |       | NR             | < 15    | < 15 | < 15 | < 15 | < 15 | < 15 |      |      |      |      |      |      |      |      |      |      |      |      |      |      |      |      |      |
| 250                 | 69.4  | V <sub>z</sub> | H = 2.7 | 0.31 | 0.19 | 0.15 | 0.24 | 0.15 | 0.12 | 0.20 | 0.12 | 0.10 |      |      |      |      |      |      |      |      |      |      |      |      |      |
|                     |       |                | H = 3.2 | 0.23 | 0.16 | 0.13 | 0.18 | 0.12 | 0.10 | 0.15 | 0.10 | 0.08 |      |      |      |      |      |      |      |      |      |      |      |      |      |
|                     |       |                | H = 3.8 | 0.18 | 0.13 | 0.11 | 0.14 | 0.10 | 0.09 | 0.11 | 0.08 | 0.07 |      |      |      |      |      |      |      |      |      |      |      |      |      |
|                     |       | P <sub>t</sub> | 12      | 12   | 12   | 7    | 7    | 7    | 4    | 4    | 4    |      |      |      |      |      |      |      |      |      |      |      |      |      |      |
|                     |       | NR             | 29      | 29   | 29   | 19   | 19   | 19   | < 15 | < 15 | < 15 |      |      |      |      |      |      |      |      |      |      |      |      |      |      |
| 350                 | 97.2  | V <sub>z</sub> | H = 2.7 | 0.43 | 0.27 | 0.21 | 0.33 | 0.21 | 0.17 | 0.28 | 0.17 | 0.14 | 0.24 | 0.15 | 0.12 | 0.23 | 0.14 | 0.12 | 0.22 | 0.14 | 0.11 |      |      |      |      |
|                     |       |                | H = 3.2 | 0.32 | 0.22 | 0.18 | 0.25 | 0.17 | 0.14 | 0.21 | 0.14 | 0.12 | 0.18 | 0.13 | 0.10 | 0.17 | 0.12 | 0.10 | 0.16 | 0.11 | 0.07 |      |      |      |      |
|                     |       |                | H = 3.8 | 0.25 | 0.18 | 0.16 | 0.19 | 0.14 | 0.12 | 0.16 | 0.12 | 0.10 | 0.14 | 0.10 | 0.09 | 0.13 | 0.10 | 0.08 | 0.13 | 0.09 | 0.08 |      |      |      |      |
|                     |       | P <sub>t</sub> | 24      | 24   | 24   | 14   | 14   | 14   | 7    | 7    | 7    | 6    | 6    | 6    | 5    | 5    | 5    | 3    | 3    | 3    |      |      |      |      |      |
|                     |       | NR             | 39      | 39   | 39   | 29   | 29   | 29   | 20   | 20   | 20   | 15   | 15   | 15   | < 15 | < 15 | < 15 | < 15 | < 15 | < 15 |      |      |      |      |      |
| 500                 | 138.9 | V <sub>z</sub> | H = 2.7 | 0.61 | 0.38 | 0.31 | 0.48 | 0.30 | 0.24 | 0.39 | 0.25 | 0.20 | 0.35 | 0.22 | 0.17 | 0.33 | 0.21 | 0.16 | 0.31 | 0.19 | 0.16 | 0.30 | 0.19 | 0.15 |      |
|                     |       |                | H = 3.2 | 0.46 | 0.32 | 0.26 | 0.36 | 0.25 | 0.20 | 0.29 | 0.20 | 0.17 | 0.26 | 0.18 | 0.15 | 0.25 | 0.17 | 0.14 | 0.23 | 0.16 | 0.13 | 0.22 | 0.15 | 0.13 |      |
|                     |       |                | H = 3.8 | 0.35 | 0.26 | 0.22 | 0.27 | 0.20 | 0.17 | 0.23 | 0.17 | 0.14 | 0.20 | 0.15 | 0.13 | 0.19 | 0.14 | 0.12 | 0.18 | 0.13 | 0.11 | 0.17 | 0.13 | 0.11 |      |
|                     |       | P <sub>t</sub> | 49      | 49   | 49   | 29   | 29   | 29   | 14   | 14   | 14   | 12   | 12   | 12   | 11   | 11   | 11   | 7    | 7    | 7    | 5    | 5    | 5    |      |      |
|                     |       | NR             | 50      | 50   | 50   | 39   | 39   | 39   | 30   | 30   | 30   | 26   | 26   | 26   | 25   | 25   | 25   | 18   | 18   | 18   | < 15 | < 15 | < 15 |      |      |
| 650                 | 180.6 | V <sub>z</sub> | H = 2.7 |      |      |      | 0.62 | 0.39 | 0.31 | 0.51 | 0.32 | 0.26 | 0.45 | 0.31 | 0.28 | 0.24 | 0.29 | 0.21 | 0.24 | 0.26 | 0.20 | 0.23 | 0.23 | 0.19 |      |
|                     |       |                | H = 3.2 |      |      |      | 0.46 | 0.32 | 0.26 | 0.38 | 0.26 | 0.22 | 0.34 | 0.23 | 0.19 | 0.32 | 0.22 | 0.18 | 0.30 | 0.21 | 0.17 | 0.29 | 0.20 | 0.17 |      |
|                     |       |                | H = 3.8 |      |      |      | 0.36 | 0.26 | 0.23 | 0.29 | 0.22 | 0.19 | 0.26 | 0.19 | 0.17 | 0.25 | 0.18 | 0.16 | 0.23 | 0.17 | 0.15 | 0.22 | 0.17 | 0.14 |      |
|                     |       | P <sub>t</sub> |         |      |      | 49   | 49   | 49   | 24   | 24   | 24   | 20   | 20   | 20   | 19   | 19   | 19   | 12   | 12   | 12   | 8    | 8    | 8    |      |      |
|                     |       | NR             |         |      |      | 47   | 47   | 47   | 38   | 38   | 38   | 34   | 34   | 34   | 32   | 32   | 32   | 26   | 26   | 26   | 21   | 21   | 21   |      |      |
| 800                 | 222.2 | V <sub>z</sub> | H = 2.7 |      |      |      |      |      |      | 0.63 | 0.39 | 0.31 | 0.56 | 0.35 | 0.28 | 0.35 | 0.33 | 0.26 | 0.50 | 0.31 | 0.25 | 0.48 | 0.30 | 0.24 |      |
|                     |       |                | H = 3.2 |      |      |      |      |      |      |      | 0.47 | 0.33 | 0.27 | 0.42 | 0.29 | 0.24 | 0.39 | 0.27 | 0.23 | 0.37 | 0.26 | 0.21 | 0.36 | 0.25 | 0.20 |
|                     |       |                | H = 3.8 |      |      |      |      |      |      |      | 0.36 | 0.27 | 0.23 | 0.32 | 0.24 | 0.20 | 0.30 | 0.23 | 0.19 | 0.29 | 0.21 | 0.18 | 0.27 | 0.20 | 0.17 |
|                     |       | P <sub>t</sub> |         |      |      |      |      |      |      |      | 36   | 36   | 36   | 30   | 30   | 30   | 28   | 28   | 28   | 18   | 18   | 18   | 12   | 12   | 12   |
|                     |       | NR             |         |      |      |      |      |      |      | 45   | 45   | 45   | 40   | 40   | 40   | 39   | 39   | 39   | 32   | 32   | 32   | 27   | 27   | 27   |      |
| 1000                | 277.8 | V <sub>z</sub> | H = 2.7 |      |      |      |      |      |      |      |      |      |      |      |      |      |      |      |      |      |      |      |      |      |      |
|                     |       |                | H = 3.2 |      |      |      |      |      |      |      |      |      |      |      |      |      |      |      |      |      |      |      |      |      |      |
|                     |       |                | H = 3.8 |      |      |      |      |      |      |      |      |      |      |      |      |      |      |      |      |      |      |      |      |      |      |
|                     |       | P <sub>t</sub> |         |      |      |      |      |      |      |      |      |      |      |      |      |      |      |      |      |      |      |      |      |      |      |
|                     |       | NR             |         |      |      |      |      |      |      |      |      |      |      |      |      |      |      |      |      |      |      |      |      |      |      |
| 1250                | 347.2 | V <sub>z</sub> | H = 2.7 |      |      |      |      |      |      |      |      |      |      |      |      |      |      |      |      |      |      |      |      |      |      |
|                     |       |                | H = 3.2 |      |      |      |      |      |      |      |      |      |      |      |      |      |      |      |      |      |      |      |      |      |      |
|                     |       |                | H = 3.8 |      |      |      |      |      |      |      |      |      |      |      |      |      |      |      |      |      |      |      |      |      |      |
|                     |       | P <sub>t</sub> |         |      |      |      |      |      |      |      |      |      |      |      |      |      |      |      |      |      |      |      |      |      |      |
|                     |       | NR             |         |      |      |      |      |      |      |      |      |      |      |      |      |      |      |      |      |      |      |      |      |      |      |
| 1600                | 444.4 | V <sub>z</sub> | H = 2.7 |      |      |      |      |      |      |      |      |      |      |      |      |      |      |      |      |      |      |      |      |      |      |
|                     |       |                | H = 3.2 |      |      |      |      |      |      |      |      |      |      |      |      |      |      |      |      |      |      |      |      |      |      |
|                     |       |                | H = 3.8 |      |      |      |      |      |      |      |      |      |      |      |      |      |      |      |      |      |      |      |      |      |      |
|                     |       | P <sub>t</sub> |         |      |      |      |      |      |      |      |      |      |      |      |      |      |      |      |      |      |      |      |      |      |      |
|                     |       | NR             |         |      |      |      |      |      |      |      |      |      |      |      |      |      |      |      |      |      |      |      |      |      |      |

**Symbols:**

- B - Distance between diffusers
- H - Room height (m)
- V<sub>z</sub> - Air flow velocity in occupied area (m)
- Pressure (P<sub>t</sub>) - All pressures are in Pa (N/m<sup>2</sup>)
- NR - Noise level index in dB based on a room absorption and one diffuser



## Round Ceiling Diffuser

### General Information:

The ceiling diffuser is a supply or return air diffuser made from an Engineering Polymer. It has a simple, visually appealing style that is suitable in commercial and domestic buildings alike. The central diffusion cone of that can be adjusted up or down by hand to control the air volume being supplied. For "shut off" the cone can be adjusted fully home to stop the air supply completely.

The radial supply air pattern of that creates a strong ceiling effect resulting in a draft-less environment. The strong ceiling effect allows it to be used in Variable Air Volume applications.

### Features:

- Non-glare mottle white finish
- Grilles are complete with snap down fixing clip and spring arrangement
- The airflow passage are smooth ensuring quiet and efficient airflow

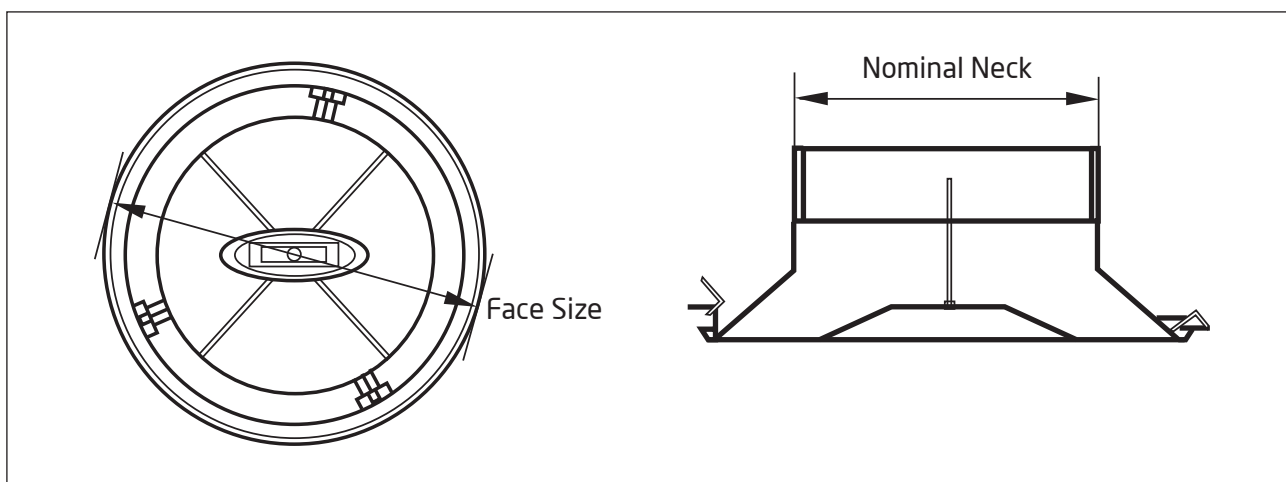

## Quick Selection Table

Data is based on isothermal conditions with a room height of 2.7m with the diffuser mounted flush in an unobstructed ceiling. Throws are given at a terminal velocity of 0.25m/s. Data is tabulated with centre cone in two-test positions 20% and 100% open respectively. Noise Ratings are based on a room absorption level of 10dB.

| Neck Size (mm)  | 150      |                |     |               |     |                |     | 200           |     |                |     |               |     |                |     |
|-----------------|----------|----------------|-----|---------------|-----|----------------|-----|---------------|-----|----------------|-----|---------------|-----|----------------|-----|
| Percentage Open | 20% Open |                |     | 100% Open     |     |                |     | 20% Open      |     |                |     | 100% Open     |     |                |     |
| Airflow (l/s)   | X        | P <sub>t</sub> | NR  | Airflow (l/s) | X   | P <sub>t</sub> | NR  | Airflow (l/s) | X   | P <sub>t</sub> | NR  | Airflow (l/s) | X   | P <sub>t</sub> | NR  |
| 15              | 1.0      | 9              | <15 | 15            | 0.5 | 2              | <15 | 25            | 1.3 | 6              | <15 | 25            | 0.7 | 1              | <15 |
| 30              | 1.3      | 38             | 16  | 30            | 1.0 | 8              | 16  | 50            | 1.6 | 25             | <15 | 50            | 1.2 | 5              | <15 |
| 45              | 1.7      | 85             | 17  | 45            | 1.3 | 18             | 18  | 75            | 2.0 | 56             | 21  | 75            | 1.6 | 12             | <15 |
| 60              | 2.0      | 151            | 20  | 60            | 1.6 | 31             | 21  | 100           | 2.3 | 100            | 33  | 100           | 2.0 | 21             | 15  |
| 75              | 2.4      | 237            | 24  | 75            | 2.0 | 49             | 25  | 125           | 2.6 | 156            | 41  | 125           | 2.3 | 32             | 19  |
| 90              | 2.8      | 241            | 29  | 90            | 2.4 | 70             | 30  | 150           | 3.0 | 224            | 55  | 150           | 2.6 | 46             | 26  |

| Neck Size (mm)  | 250      |                |     |               |     |    |     | 300           |     |                |     |               |     |                |     |
|-----------------|----------|----------------|-----|---------------|-----|----|-----|---------------|-----|----------------|-----|---------------|-----|----------------|-----|
| Percentage Open | 20% Open |                |     | 100% Open     |     |    |     | 20% Open      |     |                |     | 100% Open     |     |                |     |
| Airflow (l/s)   | X        | P <sub>t</sub> | NR  | Airflow (l/s) | X   | P  | NR  | Airflow (l/s) | X   | P <sub>t</sub> | NR  | Airflow (l/s) | X   | P <sub>t</sub> | NR  |
| 40              | 1.5      | 5              | <15 | 40            | 0.8 | 1  | <15 | 60            | 1.6 | 5              | <15 | 60            | 0.7 | 1              | <15 |
| 80              | 2.0      | 21             | <15 | 80            | 1.5 | 4  | <15 | 120           | 2.2 | 19             | <15 | 120           | 1.6 | 4              | <15 |
| 120             | 2.4      | 47             | 19  | 120           | 1.9 | 10 | <15 | 180           | 2.8 | 43             | 16  | 180           | 2.3 | 9              | <15 |
| 160             | 2.9      | 84             | 31  | 160           | 2.4 | 17 | <15 | 240           | 3.3 | 76             | 26  | 240           | 2.7 | 16             | <15 |
| 200             | 3.4      | 131            | 37  | 200           | 2.8 | 27 | 16  | 300           | 3.8 | 119            | 33  | 300           | 3.2 | 24             | 15  |
| 240             | 3.9      | 188            | 43  | 240           | 3.2 | 39 | 22  | 360           | 4.3 | 171            | 39  | 360           | 3.6 | 35             | 20  |

### Symbols:

X - Throw in metres correspond to a terminal velocity in occupied zone of 0.25m/s

Pressure ( P<sub>t</sub> ) - All pressures are in Pa (N/m<sup>2</sup>)

NR - Noise level index in dB based on a room absorption and one diffuser



## Jet Diffuser

### General Information:

The Jet Diffusers have been designed to provide an attractive option for air conditioning large areas. Ventech diffusers are perfect for situations where large supply air quantities and throw distances are required. All Jet Diffusers constructed from 2 cones that provide a uniformity of appearance through the range.

The Jet Diffuser has two separate modes. Firstly there is diffuse mode where the supply air is spread and diffused into the room over a relatively short distance. The second mode is Jet Mode that throws a high velocity jet of air over a long distance. Switching between the two modes is achieved by rotating the cone set through 180°.

Jet Diffusers can be mounted directly into the end of circular duct or can be mounted into a plenum box, which may supply air to a number of Ventech diffusers. Alternatively the diffuser may be mounted into a wall or angled ceiling.

### Features:

- Aluminium, light weight construction
- The centre can be oriented 360°
- Long distance throw at high outlet velocities
- Supplied with locking nuts to facilitate fixing to existing duct
- Powder coated finished in white as standard

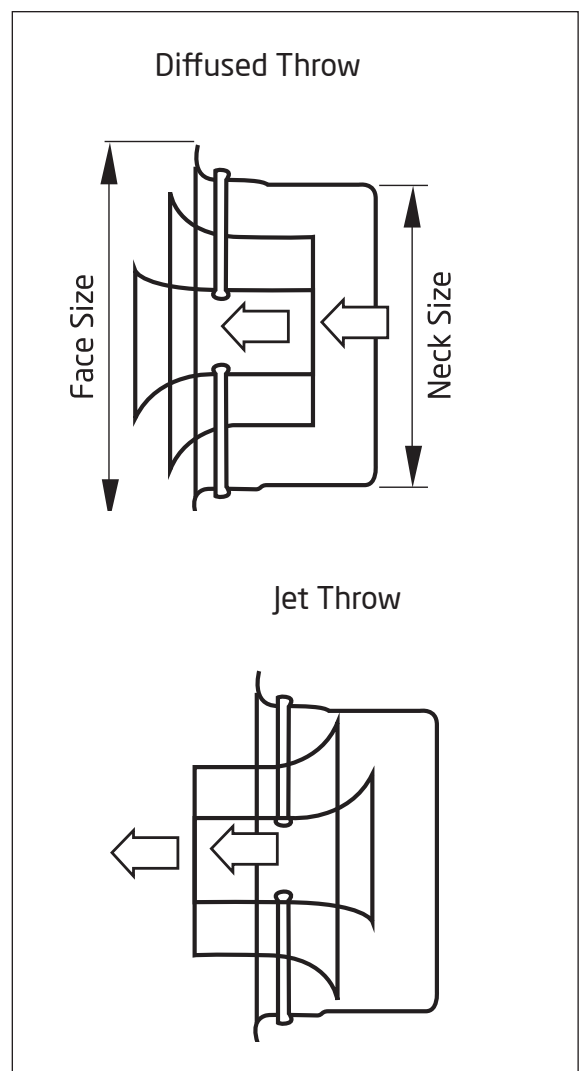

## Quick Selection Table

| Model | Neck Size (mm) | 200           |          | 250           |          | 300           |          | 350           |          | 400           |          |
|-------|----------------|---------------|----------|---------------|----------|---------------|----------|---------------|----------|---------------|----------|
|       |                | Diffuser Mode | Jet Mode | Diffuser Mode | Jet Mode | Diffuser Mode | Jet Mode | Diffuser Mode | Jet Mode | Diffuser Mode | Jet Mode |
| 100   | X              | 3.4           | 7.0      | 1.5           | 5.7      |               |          |               |          |               |          |
|       | P <sub>t</sub> | 9             | 46       | 4             | 24       |               |          |               |          |               |          |
|       | NR             | 26            | 30       | -             | 16       |               |          |               |          |               |          |
| 150   | X              | 4.9           | 9.8      | 2.5           | 8.0      | 3.0           | 6.0      |               |          |               |          |
|       | P <sub>t</sub> | 18            | 99       | 9             | 56       | 2             | 17       |               |          |               |          |
|       | NR             | 29            | 40       | 24            | 25       | -             | -        |               |          |               |          |
| 200   | X              | 7.0           | 13.8     | 4.0           | 10.0     | 4.1           | 8.2      | 3.2           | 6.5      |               |          |
|       | P <sub>t</sub> | 29            | 154      | 14            | 103      | 3             | 28       | 3             | 18       |               |          |
|       | NR             | 35            | 50       | 31            | 28       | 20            | 29       | 18            | 30       |               |          |
| 250   | X              | 9.0           | 18.0     | 5.3           | 13.0     | 5.2           | 10.2     | 4.1           | 8.2      | 6.3           | 12.2     |
|       | P <sub>t</sub> | 42            | 240      | 22            | 152      | 4             | 44       | 4             | 28       | 3.0           | 21       |
|       | NR             | 44            | 59       | 39            | 39       | 27            | 37       | 22            | 34       | 19            | 30       |
| 300   | X              |               |          | 7.0           | 15.6     | 5.9           | 11.8     | 4.8           | 9.6      | 6.6           | 12.9     |
|       | P <sub>t</sub> |               |          | 32            | 220      | 6             | 60       | 6             | 40       | 5.0           | 3.4      |
|       | NR             |               |          | 44            | 45       | 34            | 38       | 23            | 36       | 21            | 32       |
| 400   | X              |               |          | 9.7           | 21.5     | 7.8           | 15.6     | 6.4           | 12.6     | 6.8           | 13.5     |
|       | P <sub>t</sub> |               |          | 55            | 390      | 10            | 110      | 9             | 67       | 7.0           | 52       |
|       | NR             |               |          | 51            | 54       | 41            | 45       | 34            | 41       | 22            | 28       |
| 500   | X              |               |          |               |          | 9.6           | 19.2     | 8.4           | 16.8     | 7.5           | 14.8     |
|       | P <sub>t</sub> |               |          |               |          | 16            | 170      | 12            | 104      | 12            | 102      |
|       | NR             |               |          |               |          | 47            | 55       | 38            | 46       | 31            | 37       |
| 600   | X              |               |          |               |          | 12.0          | 24       | 9.8           | 19.7     | 8.0           | 15.9     |
|       | P <sub>t</sub> |               |          |               |          | 22            | 235      | 17            | 147      | 19            | 152      |
|       | NR             |               |          |               |          | 52            | 63       | 45            | 52       | 39            | 44       |
| 800   | X              |               |          |               |          | 16.0          | 31.2     | 13.2          | 26.4     | 8.4           | 16.9     |
|       | P <sub>t</sub> |               |          |               |          | 37            | 418      | 33            | 258      | 28            | 219      |
|       | NR             |               |          |               |          | 70            | 75       | 51            | 61       | 46            | 54       |
| 1000  | X              |               |          |               |          |               |          | 16.8          | 33.6     | 9.4           | 18.8     |
|       | P <sub>t</sub> |               |          |               |          |               |          | 57            | 396      | 38            | 268      |
|       | NR             |               |          |               |          |               |          | 68            | 70       | 54            | 57       |

**Symbols:**

X - Throw in metres correspond to a terminal velocity in occupied zone of 0.25m/s

Pressure (P<sub>t</sub>) - All pressures are in Pa (N/m<sup>2</sup>)

NR - Noise level index in dB based on a room absorption and one diffuser



## Jetflo Diffuser

### Features:

- Suitable for heating, cooling and exhaust applications
- From A.B.S polymers providing long term strength and rigidity
- Complete with the twin spring clip arrangement found on the round ceiling diffusers
- Finished standard white
- Easily adjustable butterfly damper which can be adjusted from the face of the grille using a simple push-in dial

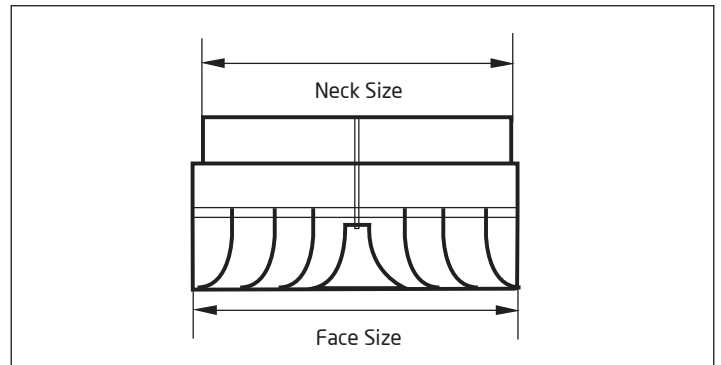

| Nominal Neck Metric ( X ) | Face Size ( A ) |
|---------------------------|-----------------|
| 150 mm                    | 205 mm          |
| 200 mm                    | 260 mm          |
| 250 mm                    | 305 mm          |

\* Grilles are powder coated white as standard

\* The first number is for horizontal dimension and the second number is for vertical dimension

## Quick Selection Table

Data is based on isothermal conditions with a room height of 2.7m with the diffuser mounted flush in an unobstructed ceiling. Throws are given at a terminal velocity of 0.25m/s. Data is tabulated with centre cone in two-test positions 20% and 100% open respectively. Noise Ratings are based on a room absorption level of 10dB.

| Neck Size (mm)  | 150           |     |                |           |               |     |                | 200      |               |     |                |           |               |     |                |     |
|-----------------|---------------|-----|----------------|-----------|---------------|-----|----------------|----------|---------------|-----|----------------|-----------|---------------|-----|----------------|-----|
|                 | 20% Open      |     |                | 100% Open |               |     |                | 20% Open |               |     |                | 100% Open |               |     |                |     |
| Percentage Open | Airflow (l/s) | X   | P <sub>t</sub> | NR        | Airflow (l/s) | X   | P <sub>t</sub> | NR       | Airflow (l/s) | X   | P <sub>t</sub> | NR        | Airflow (l/s) | X   | P <sub>t</sub> | NR  |
|                 | 16.5          | 1.0 | 9              | <15       | 16.5          | 0.5 | 2              | <15      | 27.5          | 1.3 | 6              | <15       | 27.5          | 0.7 | 1              | <15 |
|                 | 33            | 1.3 | 38             | 16        | 33            | 1.0 | 8              | 16       | 55            | 1.6 | 25             | <15       | 55            | 1.2 | 5              | <15 |
|                 | 49.5          | 1.7 | 85             | 17        | 49.5          | 1.3 | 18             | 18       | 82.5          | 2.0 | 56             | 21        | 82.5          | 1.6 | 12             | <15 |
|                 | 66            | 2.0 | 151            | 20        | 66            | 1.6 | 31             | 21       | 110           | 2.3 | 100            | 33        | 110           | 2.0 | 21             | 15  |
|                 | 82.5          | 2.4 | 237            | 24        | 82.5          | 2.0 | 49             | 25       | 137.5         | 2.6 | 156            | 41        | 137.5         | 2.3 | 32             | 19  |
|                 | 99            | 2.8 | 241            | 29        | 99            | 2.4 | 70             | 30       | 165           | 3.0 | 224            | 55        | 165           | 2.6 | 46             | 26  |

| Neck Size (mm)  | 250           |     |                |           |               |     |                | 300      |               |     |                |           |               |     |                |     |
|-----------------|---------------|-----|----------------|-----------|---------------|-----|----------------|----------|---------------|-----|----------------|-----------|---------------|-----|----------------|-----|
|                 | 20% Open      |     |                | 100% Open |               |     |                | 20% Open |               |     |                | 100% Open |               |     |                |     |
| Percentage Open | Airflow (l/s) | X   | P <sub>t</sub> | NR        | Airflow (l/s) | X   | P <sub>t</sub> | NR       | Airflow (l/s) | X   | P <sub>t</sub> | NR        | Airflow (l/s) | X   | P <sub>t</sub> | NR  |
|                 | 44            | 1.5 | 5              | <15       | 44            | 0.8 | 1              | <15      | 66            | 1.6 | 5              | <15       | 66            | 0.7 | 1              | <15 |
|                 | 88            | 2.0 | 21             | <15       | 88            | 1.5 | 4              | <15      | 132           | 2.2 | 19             | <15       | 132           | 1.6 | 4              | <15 |
|                 | 132           | 2.4 | 47             | 19        | 132           | 1.9 | 10             | <15      | 198           | 2.8 | 43             | 16        | 198           | 2.3 | 9              | <15 |
|                 | 176           | 2.9 | 84             | 31        | 176           | 2.4 | 17             | <15      | 264           | 3.3 | 76             | 26        | 264           | 2.7 | 16             | <15 |
|                 | 220           | 3.4 | 131            | 37        | 220           | 2.8 | 27             | 16       | 330           | 3.8 | 119            | 33        | 330           | 3.2 | 24             | 15  |
|                 | 264           | 3.9 | 188            | 43        | 264           | 3.2 | 39             | 22       | 396           | 4.3 | 171            | 39        | 396           | 3.6 | 35             | 20  |

### Symbols:

X - Throw in metres correspond to a terminal velocity in occupied zone of 0.25m/s

Pressure ( P<sub>t</sub> ) - All pressures are in Pa (N/m<sup>2</sup>)

NR - Noise level index in dB based on a room absorption and one diffuser



## Jet Nozzle Diffuser

### General Information:

Interior architecture are increasingly designing larger spaces for hotels, shopping malls, salons, convention centres, airport vestibules, passenger stations, social halls, etc.

In addition to effective air blowing at a long distance through nozzles (originally designed for industrial facilities), the use of these terminal units in more comfortable surroundings requires utmost attention to aesthetic design.

### Features:

- From molded and spun aluminium sheeting ensuring functional strength
- Performance gives an attractive and aesthetically pleasing appearance
- Incorporating the barrel with fixing collar, swivelling nozzle and trim ring
- Powder coated white as standard

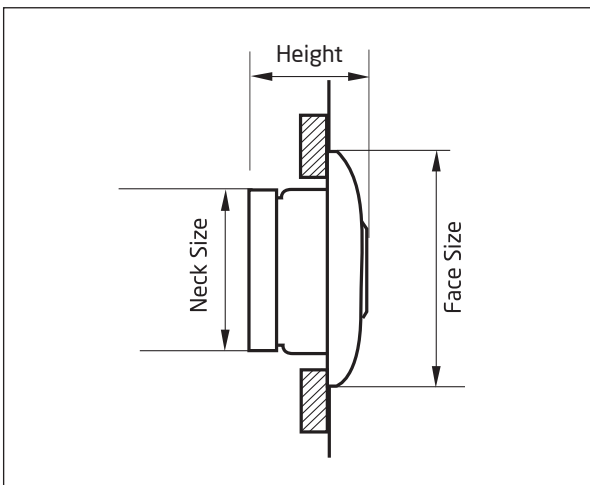

| Nominal Neck Metric ( X ) | Face Size ( A ) | Height |
|---------------------------|-----------------|--------|
| 125 mm                    | 172 mm          | 96 mm  |
| 200 mm                    | 265 mm          | 142 mm |
| 250 mm                    | 314 mm          | 179 mm |
| 350 mm                    | 433 mm          | 251 mm |
| 400 mm                    | 495 mm          | 285 mm |

\* Grilles are powder coated white as standard

\* The first number is for horizontal dimension and the second number is for vertical dimension

**Quick Selection Table**

| Flow rate           |       | No. of slots   | 125              |                  |                  | 200              |                  |                  | 250              |                  |                  | 300              |                  |                  | 350              |                  |                  | 400              |                  |                  |                |    |
|---------------------|-------|----------------|------------------|------------------|------------------|------------------|------------------|------------------|------------------|------------------|------------------|------------------|------------------|------------------|------------------|------------------|------------------|------------------|------------------|------------------|----------------|----|
| (m <sup>3</sup> /h) | (l/s) |                | A <sub>k</sub>   | X <sub>0.3</sub> | X <sub>0.5</sub> | X <sub>1</sub>   | X <sub>0.3</sub> | X <sub>0.5</sub> | X <sub>1</sub>   | X <sub>0.3</sub> | X <sub>0.5</sub> | X <sub>1</sub>   | X <sub>0.3</sub> | X <sub>0.5</sub> | X <sub>1</sub>   | X <sub>0.3</sub> | X <sub>0.5</sub> | X <sub>1</sub>   | X <sub>0.3</sub> | X <sub>0.5</sub> | X <sub>1</sub> |    |
|                     |       | A <sub>k</sub> | 0.0025           |                  |                  | 0.0060           |                  |                  | 0.0087           |                  |                  | 0.0390           |                  |                  | 0.0422           |                  |                  | 0.1084           |                  |                  |                |    |
| 75                  | 20.8  | -              | X <sub>0.3</sub> | X <sub>0.5</sub> | X <sub>1</sub>   | X <sub>0.3</sub> | X <sub>0.5</sub> | X <sub>1</sub>   | X <sub>0.3</sub> | X <sub>0.5</sub> | X <sub>1</sub>   | X <sub>0.3</sub> | X <sub>0.5</sub> | X <sub>1</sub>   | X <sub>0.3</sub> | X <sub>0.5</sub> | X <sub>1</sub>   | X <sub>0.3</sub> | X <sub>0.5</sub> | X <sub>1</sub>   |                |    |
|                     |       | X              | 11.4             | 6.9              | 3.4              |                  |                  |                  |                  |                  |                  |                  |                  |                  |                  |                  |                  |                  |                  |                  |                |    |
|                     |       | V <sub>k</sub> | 8.3              | 8.3              | 8.3              |                  |                  |                  |                  |                  |                  |                  |                  |                  |                  |                  |                  |                  |                  |                  |                |    |
|                     |       | P <sub>t</sub> | 37               | 37               | 37               |                  |                  |                  |                  |                  |                  |                  |                  |                  |                  |                  |                  |                  |                  |                  |                |    |
| 125                 | 34.7  | NR             | <15              | <15              | <15              |                  |                  |                  |                  |                  |                  |                  |                  |                  |                  |                  |                  |                  |                  |                  |                |    |
|                     |       | X              | 19.1             | 11.4             | 5.7              | 11.5             | 6.9              | 3.4              |                  |                  |                  |                  |                  |                  |                  |                  |                  |                  |                  |                  |                |    |
|                     |       | V <sub>k</sub> | 13.9             | 13.9             | 13.9             | 5.8              | 5.8              | 5.8              |                  |                  |                  |                  |                  |                  |                  |                  |                  |                  |                  |                  |                |    |
|                     |       | P <sub>t</sub> | 103              | 103              | 103              | 17               | 17               | 17               |                  |                  |                  |                  |                  |                  |                  |                  |                  |                  |                  |                  |                |    |
| 175                 | 48.6  | NR             | 28               | 28               | 28               | <15              | <15              | <15              |                  |                  |                  |                  |                  |                  |                  |                  |                  |                  |                  |                  |                |    |
|                     |       | X              | 26.7             | 16.0             | 8.0              | 16.1             | 9.6              | 4.8              | 8.3              | 5.2              | 2.4              |                  |                  |                  |                  |                  |                  |                  |                  |                  |                |    |
|                     |       | V <sub>k</sub> | 19.4             | 19.4             | 19.4             | 8.1              | 8.1              | 8.1              | 3.4              | 3.4              | 3.4              |                  |                  |                  |                  |                  |                  |                  |                  |                  |                |    |
|                     |       | P <sub>t</sub> | 202              | 202              | 202              | 34               | 34               | 34               | 7                | 7                | 7                |                  |                  |                  |                  |                  |                  |                  |                  |                  |                |    |
| 250                 | 69.4  | NR             | 39               | 39               | 39               | 15               | 15               | 15               | <15              | <15              | <15              |                  |                  |                  |                  |                  |                  |                  |                  |                  |                |    |
|                     |       | X              | >30              | 22.9             | 11.4             | 22.9             | 13.8             | 6.9              | 20               | 9.2              | 4.8              | 12.9             | 7.8              | 3.9              |                  |                  |                  |                  |                  |                  |                |    |
|                     |       | V <sub>k</sub> | 27.7             | 27.7             | 27.7             | 11.5             | 11.5             | 11.5             | 7.6              | 7.6              | 7.6              | 3.8              | 3.8              | 3.8              |                  |                  |                  |                  |                  |                  |                |    |
|                     |       | P <sub>t</sub> | 411              | 411              | 411              | 69               | 69               | 69               | 30               | 30               | 30               | 7                | 7                | 7                |                  |                  |                  |                  |                  |                  |                |    |
| 350                 | 97.2  | NR             | 49               | 49               | 49               | 26               | 26               | 26               | 18               | 18               | 18               | <15              | <15              | <15              |                  |                  |                  |                  |                  |                  |                |    |
|                     |       | X              |                  |                  |                  | >30              | 19.3             | 9.6              | 23.2             | 12.2             | 6.3              | 18.1             | 10.9             | 5.4              | 16.3             | 8.2              | 4.0              |                  |                  |                  |                |    |
|                     |       | V <sub>k</sub> |                  |                  |                  | 16.1             | 16.1             | 16.1             | 12.1             | 12.1             | 12.1             | 5.3              | 5.3              | 5.3              | 2.6              | 2.6              | 2.6              |                  |                  |                  |                |    |
|                     |       | P <sub>t</sub> |                  |                  |                  | 134              | 134              | 134              | 52               | 52               | 52               | 14               | 14               | 14               | 6.0              | 6.0              | 6.0              |                  |                  |                  |                |    |
| 500                 | 138.9 | NR             |                  |                  |                  | 36               | 36               | 36               | 26               | 26               | 26               | <15              | <15              | <15              | <15              | <15              | <15              |                  |                  |                  |                |    |
|                     |       | X              |                  |                  |                  | >32              | 27.5             | 13.8             | >30              | 23.5             | 10.2             | 25.9             | 15.5             | 7.8              | 23.2             | 12.3             | 6.4              | 17.3             | 10.4             | 5.2              |                |    |
|                     |       | V <sub>k</sub> |                  |                  |                  | 23               | 23               | 23               | 13.6             | 13.6             | 13.6             | 7.5              | 7.5              | 7.5              | 5                | 5                | 5                | 3.6              | 3.6              | 3.6              |                |    |
|                     |       | P <sub>t</sub> |                  |                  |                  | 274              | 274              | 274              | 120              | 120              | 120              | 28               | 28               | 28               | 12               | 12               | 12               | 6                | 6                | 6                |                |    |
| 700                 | 194.4 | NR             |                  |                  |                  | 47               | 47               | 47               | 23               | 23               | 23               | 17               | 17               | 17               | <15              | <15              | <15              | <15              | <15              | <15              |                |    |
|                     |       | X              |                  |                  |                  |                  |                  |                  | >30              | 24.6             | 12.3             | >30              | 21.7             | 10.9             | >30              | 16.3             | 8.5              | 24.3             | 14.6             | 7.3              |                |    |
|                     |       | V <sub>k</sub> |                  |                  |                  |                  |                  |                  | 15.3             | 15.3             | 15.3             | 10.6             | 10.6             | 10.6             | 8.2              | 8.2              | 8.2              | 5                | 5                | 5                |                |    |
|                     |       | P <sub>t</sub> |                  |                  |                  |                  |                  |                  | 123              | 123              | 123              | 55               | 55               | 55               | 27               | 27               | 27               | 13               | 13               | 13               |                |    |
| 1000                | 277.8 | NR             |                  |                  |                  |                  |                  |                  | 41               | 41               | 41               | 27               | 27               | 27               | 18               | 18               | 18               | <15              | <15              | <15              |                |    |
|                     |       | X              |                  |                  |                  |                  |                  |                  |                  |                  |                  | >30              | >30              | 15.5             | 30               | >26.2            | 13.2             | >30              | 20.8             | 10.4             |                |    |
|                     |       | V <sub>k</sub> |                  |                  |                  |                  |                  |                  |                  |                  |                  | 15.1             | 15.1             | 15.1             | 12.1             | 12.1             | 12.1             | 7.1              | 7.1              | 7.1              |                |    |
|                     |       | P <sub>t</sub> |                  |                  |                  |                  |                  |                  |                  |                  |                  | 113              | 113              | 113              | 56               | 56               | 56               | 26               | 26               | 26               |                |    |
| 1400                | 388.9 | NR             |                  |                  |                  |                  |                  |                  |                  |                  |                  | 38               | 38               | 38               | 27               | 27               | 27               | 23               | 23               | 23               |                |    |
|                     |       | X              |                  |                  |                  |                  |                  |                  |                  |                  |                  | >30              | >30              | 21.7             | >30              | >30              | 17.6             | >30              | 29.1             | 14.6             |                |    |
|                     |       | V <sub>k</sub> |                  |                  |                  |                  |                  |                  |                  |                  |                  | 21.1             | 21.1             | 21.1             | 15.2             | 15.2             | 15.2             | 10               | 10               | 10               |                |    |
|                     |       | P <sub>t</sub> |                  |                  |                  |                  |                  |                  |                  |                  |                  | 222              | 222              | 222              | 121              | 121              | 121              | 51               | 51               | 51               |                |    |
| 1900                | 527.8 | NR             |                  |                  |                  |                  |                  |                  |                  |                  |                  |                  |                  |                  | 48               | 48               | 48               | 38               | 38               | 38               |                |    |
|                     |       | X              |                  |                  |                  |                  |                  |                  |                  |                  |                  |                  |                  |                  | >30              | >30              | 27               | >30              | >30              | 19.8             |                |    |
|                     |       | V <sub>k</sub> |                  |                  |                  |                  |                  |                  |                  |                  |                  |                  |                  |                  |                  | 20.1             | 20.1             | 20.1             | 13.5             | 13.5             | 13.5           |    |
|                     |       | P <sub>t</sub> |                  |                  |                  |                  |                  |                  |                  |                  |                  |                  |                  |                  |                  | 162              | 162              | 162              | 93               | 93               | 93             |    |
| 2500                | 694.4 | NR             |                  |                  |                  |                  |                  |                  |                  |                  |                  |                  |                  |                  |                  |                  |                  | 52               | 52               | 52               |                |    |
|                     |       | X              |                  |                  |                  |                  |                  |                  |                  |                  |                  |                  |                  |                  |                  |                  |                  | >30              | >30              | 26               |                |    |
|                     |       | V <sub>k</sub> |                  |                  |                  |                  |                  |                  |                  |                  |                  |                  |                  |                  |                  |                  |                  |                  | 17.8             | 17.8             | 17.8           |    |
|                     |       | P <sub>t</sub> |                  |                  |                  |                  |                  |                  |                  |                  |                  |                  |                  |                  |                  |                  |                  |                  | 161              | 161              | 161            |    |
|                     |       |                |                  |                  |                  |                  |                  |                  |                  |                  |                  |                  |                  |                  |                  |                  |                  |                  |                  | 50               | 50             | 50 |

**Symbols:**

- A<sub>k</sub> - Effective area
- V<sub>k</sub> - Effective velocity in m/s
- X - Throw in metres correspond to a terminal velocity in occupied zone of 0.25m/s
- Pressure ( P<sub>t</sub> ) - All pressures are in Pa (N/m<sup>2</sup>)
- NR - Noise level index in dB based on a room absorption and one diffuser

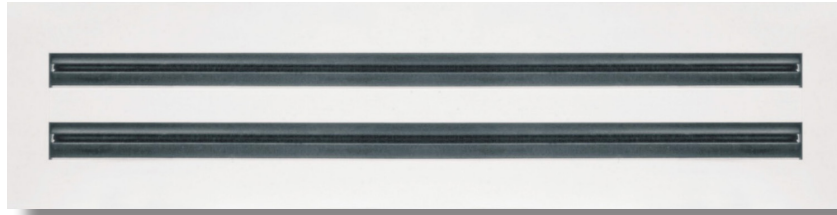

## Linear Slot Diffuser

### General Information:

Ventech produce Linear Slot Diffusers from specially drawn aluminium profiles. They are suitable for ceiling and high side-wall applications. Thanks to the connection possibilities of the slot diffusers it is possible to create continuous diffusers in multiple metres and with different corner angles. The two continuous blade type dampers enable to select the throw direction. Upon demand it is possible to mount sliding type volume regulating dampers at the entries of the slot diffusers.

It is also possible to produce the slot diffusers with plenum boxes. The plenum boxes are produced with side entries only, insulated or uninsulated in accordance with customer's demand. Standard colors of the diffusers are white and other colors are also possible upon customer's request.

### Features:

- Made of high quality extruded aluminium profile
- Designed for variable air volume systems
- The directions and volume of the discharge air can be adjusted by moving the pattern controllers
- Full 180 ° pattern controller adjustment means there is no left or right, specifying ordering and installing are simplified
- Multiple sections are provided with alignment accessories to provide superior, positive field alignment
- Size manufactured on request
- Up to 8 slots available

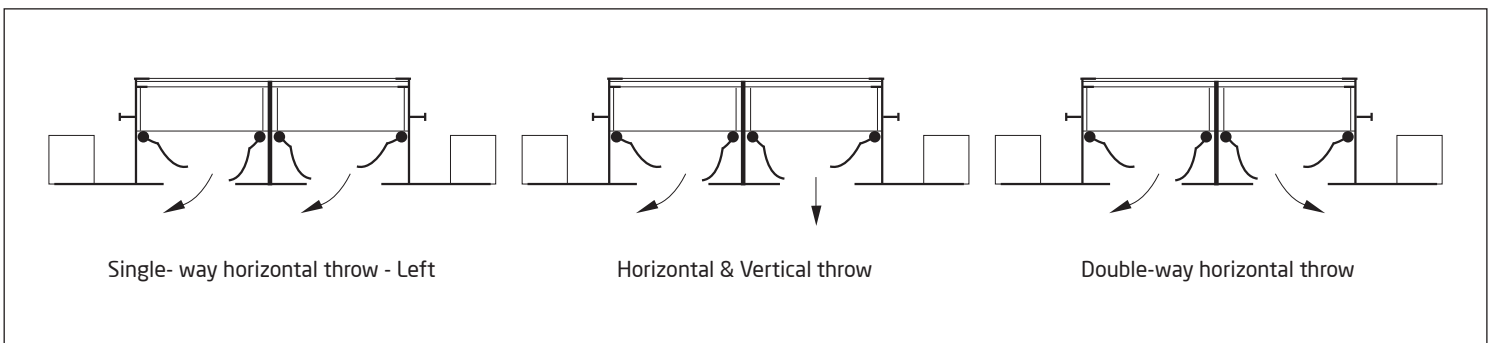

## General notes on the quick selection table:

For supply or return air, fully adjustable loose core linear slot diffuser with unique air pattern control design. The air pattern can be adjusted in situ or factory, set to suit design requirements. It is suitable for ceiling mounting applications. The loose core linear slot diffuser's unique design allows the installer to simply push the complete core of the diffuser upwards to allow it to be screw fixed to the box above then simply dropped back down into the frame.

### For the selection tables with lateral discharge:

- The diffuser is located along the longitudinal axis of the ceiling, next to the wall, in a room of the following size:

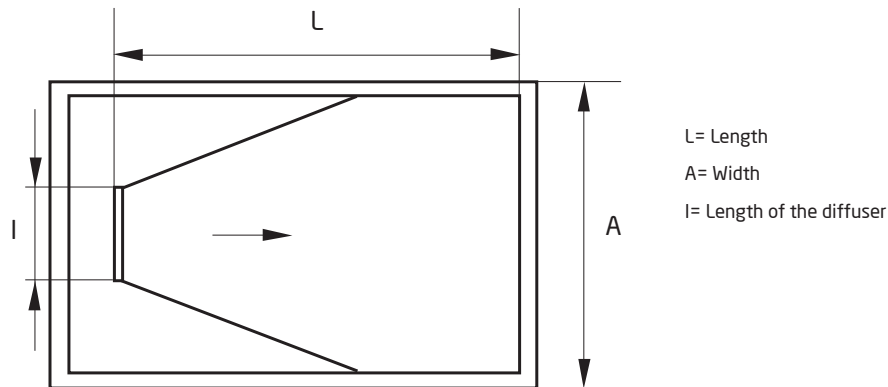

- The air jet is adherent (Coanda effect), i.e., the diffuser is mounted flush with the ceiling.

### For the selection tables with vertical discharge:

- The diffuser is located in the middle of the ceiling in a square room.
- Positioning for vertical discharge, as non-adhering jet.
- The diffuser length is less than 0.5 times the width of the room and less than 0.5 times the throw.
- The pressure  $P_t$  is measured inside the duct upstream of the plenum box.
- The height of the room is  $3 \pm 0.5$ m.
- The  $\Delta T$  is equal to  $-10^\circ\text{C}$ , the temperature difference between the room and the supply air.
- The maximum velocity is 0.25m/s in the occupied zone.

Correction factor for width to length ratio of the room ( applied on both 20 & 25mm ).

The factor is known as  $C_a$ . To calculate, divide the diffuser width less length by the length of the room. This is applicable to linear slot diffusers with lateral discharge. In diffusers with vertical discharge,  $C_a$  is equal to 1, since these diffusers have been tested in a square room ( $A/L = 1$ ).

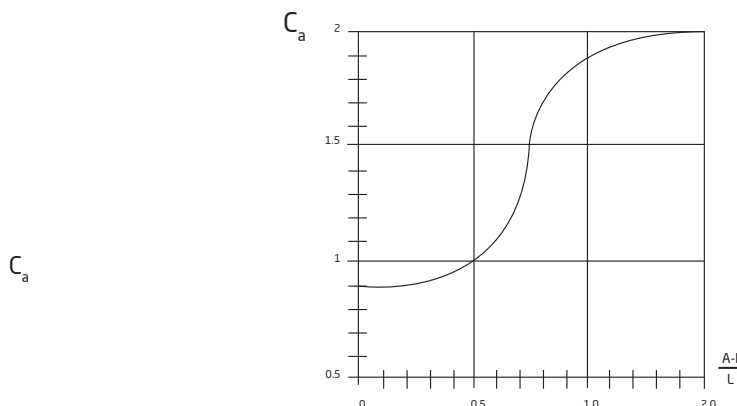

# Linear Slot Diffuser 20

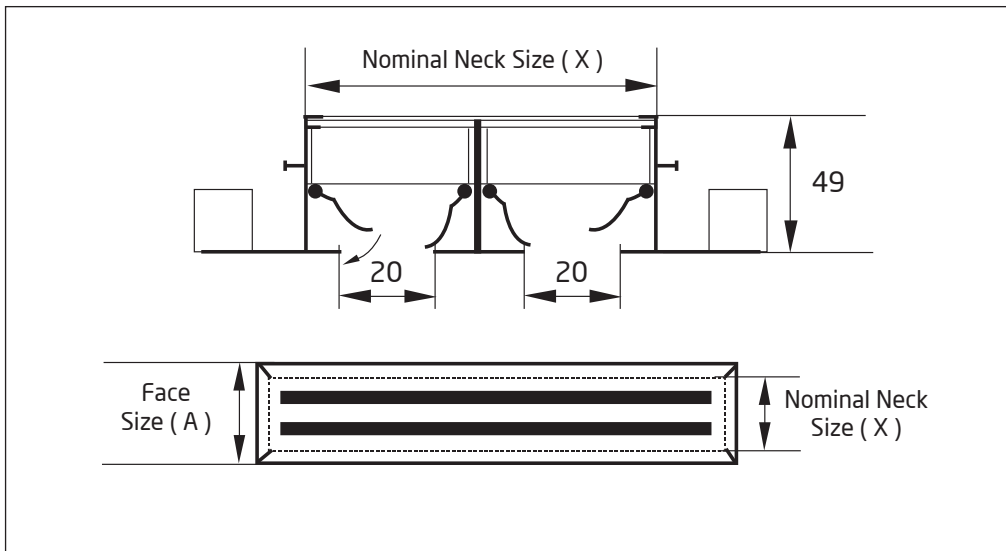
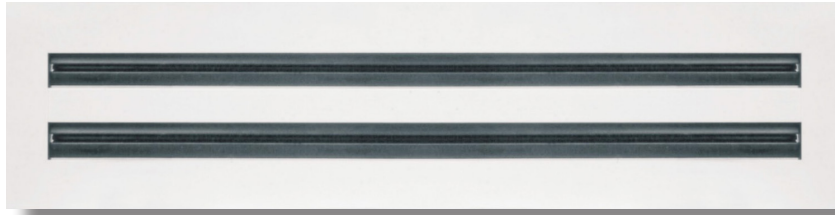

| No. of Slot | Nominal Neck Metric ( X ) | Face Size ( A ) |
|-------------|---------------------------|-----------------|
| 1 Slot      | 40 mm                     | 84 mm           |
| 2 Slots     | 76 mm                     | 120 mm          |
| 3 Slots     | 111mm                     | 155 mm          |
| 4 Slots     | 147 mm                    | 191 mm          |
| 5 Slots     | 182 mm                    | 226 mm          |
| 6 Slots     | 218 mm                    | 262 mm          |

\* Grilles are powder coated white as standard

\* Length dimension can be modified based on different specification.

**Quick Selection Table**

| Flow rate           |       | Dim.           | 600-1   | 900-1   | 900-1   | 1500-1  | 900-2   | 1200-2  | 900-3   | 1500-2  | 1200-3  | 1500-3  | 1200-4  | 1500-4  |
|---------------------|-------|----------------|---------|---------|---------|---------|---------|---------|---------|---------|---------|---------|---------|---------|
| (m <sup>3</sup> /h) | (l/s) |                |         |         | 2000-1  |         | 600-3   | 600-4   |         |         | 900-4   |         |         |         |
|                     |       | A <sub>k</sub> | 0.00598 | 0.00897 | 0.01196 | 0.01495 | 0.01794 | 0.02391 | 0.02690 | 0.02989 | 0.03587 | 0.04484 | 0.04783 | 0.05978 |
| 60                  | 16.7  | V <sub>k</sub> | 2.8     | 1.9     | 1.4     | 1.1     |         |         |         |         |         |         |         |         |
|                     |       | X              | 1.5     | 1.2     | 1.0     | 0.9     |         |         |         |         |         |         |         |         |
|                     |       | P <sub>t</sub> | 19      | 8       | 5       | 3       |         |         |         |         |         |         |         |         |
|                     |       | NR             | 27      | <20     | <20     | <20     |         |         |         |         |         |         |         |         |
| 80                  | 22.2  | V <sub>k</sub> | 3.7     | 2.5     | 1.9     | 1.5     | 1.2     |         |         |         |         |         |         |         |
|                     |       | X              | 2.0     | 1.6     | 1.4     | 1.2     | 1.1     |         |         |         |         |         |         |         |
|                     |       | P <sub>t</sub> | 35      | 14      | 9       | 6       | 5       |         |         |         |         |         |         |         |
|                     |       | NR             | 35      | 27      | 21      | <20     | <20     |         |         |         |         |         |         |         |
| 100                 | 27.8  | V <sub>k</sub> | 4.6     | 3.1     | 2.3     | 1.9     | 1.5     | 1.2     | 1.0     |         |         |         |         |         |
|                     |       | X              | 2.4     | 2.0     | 1.7     | 1.5     | 1.4     | 1.2     | 1.2     |         |         |         |         |         |
|                     |       | P <sub>t</sub> | 54      | 21      | 14      | 9       | 8       | 5       | 4       |         |         |         |         |         |
|                     |       | NR             | 41      | 33      | 27      | 23      | <20     | <20     | <20     |         |         |         |         |         |
| 140                 | 38.9  | V <sub>k</sub> | 6.5     | 4.3     | 3.3     | 2.6     | 2.2     | 1.6     | 1.4     | 1.3     | 1.1     |         |         |         |
|                     |       | X              | 3.4     | 2.8     | 2.4     | 2.2     | 2.0     | 1.7     | 1.6     | 1.5     | 1.4     |         |         |         |
|                     |       | P <sub>t</sub> | 106     | 41      | 28      | 18      | 15      | 11      | 8       | 4       | 4       |         |         |         |
|                     |       | NR             | 51      | 42      | 37      | 32      | 29      | 23      | 21      | <20     | <20     |         |         |         |
| 180                 | 50.0  | V <sub>k</sub> |         | 5.6     | 4.2     | 3.3     | 2.8     | 2.1     | 1.9     | 1.7     | 1.4     | 1.1     | 1.0     |         |
|                     |       | X              |         | 3.6     | 3.1     | 2.8     | 2.5     | 2.2     | 2.1     | 2.0     | 1.8     | 1.6     | 1.6     |         |
|                     |       | P <sub>t</sub> |         | 68      | 46      | 30      | 24      | 18      | 13      | 7       | 7       | 5       | 4       |         |
|                     |       | NR             |         | 49      | 44      | 39      | 36      | 30      | 27      | 25      | 24      | <20     | <20     |         |
| 200                 | 55.6  | V <sub>k</sub> |         | 6.2     | 4.6     | 3.7     | 3.1     | 2.3     | 2.1     | 1.9     | 1.5     | 1.2     | 1.2     |         |
|                     |       | X              |         | 4.0     | 3.5     | 3.1     | 2.8     | 2.4     | 2.3     | 2.2     | 2.0     | 1.8     | 1.7     |         |
|                     |       | P <sub>t</sub> |         | 84      | 57      | 36      | 30      | 22      | 16      | 9       | 8       | 6       | 5       |         |
|                     |       | NR             |         | 52      | 47      | 42      | 38      | 33      | 30      | 28      | 27      | 22      | 21      |         |
| 250                 | 69.4  | V <sub>k</sub> |         |         | 5.8     | 4.6     | 3.9     | 2.9     | 2.6     | 2.3     | 1.9     | 1.5     | 1.5     | 1.2     |
|                     |       | X              |         |         | 4.3     | 3.9     | 3.5     | 3.1     | 2.9     | 2.7     | 2.5     | 2.2     | 2.2     | 1.9     |
|                     |       | P <sub>t</sub> |         |         | 89      | 57      | 47      | 34      | 24      | 14      | 13      | 9       | 8       | 5       |
|                     |       | NR             |         |         | 53      | 48      | 45      | 39      | 37      | 34      | 33      | 28      | 27      | 23      |
| 300                 | 83.3  | V <sub>k</sub> |         |         |         | 5.6     | 4.6     | 3.5     | 3.1     | 2.8     | 2.3     | 1.9     | 1.7     | 1.4     |
|                     |       | X              |         |         |         | 4.6     | 4.2     | 3.7     | 3.5     | 3.3     | 3.0     | 2.7     | 2.6     | 2.3     |
|                     |       | P <sub>t</sub> |         |         |         | 82      | 68      | 49      | 35      | 20      | 19      | 13      | 11      | 7       |
|                     |       | NR             |         |         |         | 53      | 50      | 44      | 42      | 40      | 38      | 33      | 32      | 28      |
| 400                 | 111.1 | V <sub>k</sub> |         |         |         |         |         | 4.6     | 4.1     | 3.7     | 3.1     | 2.5     | 2.3     | 1.9     |
|                     |       | X              |         |         |         |         |         | 4.9     | 4.6     | 4.4     | 4.0     | 3.6     | 3.5     | 3.1     |
|                     |       | P <sub>t</sub> |         |         |         |         |         | 87      | 62      | 35      | 34      | 23      | 20      | 13      |
|                     |       | NR             |         |         |         |         |         | 52      | 50      | 47      | 46      | 41      | 40      | 36      |
| 500                 | 138.9 | V <sub>k</sub> |         |         |         |         |         |         |         | 4.6     | 3.9     | 3.1     | 2.9     | 2.3     |
|                     |       | X              |         |         |         |         |         |         |         | 5.5     | 5.0     | 4.5     | 4.3     | 3.9     |
|                     |       | P <sub>t</sub> |         |         |         |         |         |         |         | 55      | 53      | 36      | 32      | 20      |
|                     |       | NR             |         |         |         |         |         |         | 54      | 52      | 48      | 46      | 42      |         |
| 600                 | 166.7 | V <sub>k</sub> |         |         |         |         |         |         |         |         |         | 3.7     | 3.5     | 2.8     |
|                     |       | X              |         |         |         |         |         |         |         |         |         | 5.4     | 5.2     | 4.6     |
|                     |       | P <sub>t</sub> |         |         |         |         |         |         |         |         |         | 52      | 45      | 29      |
|                     |       | NR             |         |         |         |         |         |         |         |         | 53      | 51      | 47      |         |
| 700                 | 194.4 | V <sub>k</sub> |         |         |         |         |         |         |         |         |         |         | 4.1     | 3.3     |
|                     |       | X              |         |         |         |         |         |         |         |         |         |         | 6.1     | 5.4     |
|                     |       | P <sub>t</sub> |         |         |         |         |         |         |         |         |         |         | 62      | 40      |
|                     |       | NR             |         |         |         |         |         |         |         |         |         | 56      | 51      |         |
| 800                 | 222.2 | V <sub>k</sub> |         |         |         |         |         |         |         |         |         |         |         | 3.7     |
|                     |       | X              |         |         |         |         |         |         |         |         |         |         |         | 6.2     |
|                     |       | P <sub>t</sub> |         |         |         |         |         |         |         |         |         |         |         | 52      |
|                     |       | NR             |         |         |         |         |         |         |         |         |         |         |         | 55      |

**Symbols:**

- A<sub>k</sub> - Effective area
- V<sub>k</sub> - Effective velocity in m/s
- X - Throw in metres correspond to a terminal velocity in occupied zone of 0.25m/s
- Pressure (P<sub>t</sub>) - All pressures are in Pa (N/m<sup>2</sup>)
- NR - Noise level index in dB based on a room absorption and one diffuser

## Quick Selection Table

| Flow rate           |       | Dim.           | 600-1   | 900-1   | 900-1   | 1500-1  | 900-2   | 1200-2  | 1500-2  |
|---------------------|-------|----------------|---------|---------|---------|---------|---------|---------|---------|
| (m <sup>3</sup> /h) | (l/s) |                |         |         | 2000-1  |         |         |         |         |
|                     |       | A <sub>k</sub> | 0.00598 | 0.00897 | 0.01196 | 0.01495 | 0.01794 | 0.02391 | 0.02690 |
| 60                  | 16.7  | V <sub>k</sub> | 2.7     | 1.8     |         |         |         |         |         |
|                     |       | X              | 1.1     | 0.9     |         |         |         |         |         |
|                     |       | P <sub>t</sub> | 31      | 12      |         |         |         |         |         |
|                     |       | NR             | 20      | <20     |         |         |         |         |         |
| 80                  | 22.2  | V <sub>k</sub> | 3.6     | 2.4     | 1.8     | 1.4     |         |         |         |
|                     |       | X              | 1.5     | 1.2     | 1.0     | 0.9     |         |         |         |
|                     |       | P <sub>t</sub> | 54      | 21      | 14      | 9       |         |         |         |
|                     |       | NR             | 29      | 22      | <20     | <20     |         |         |         |
| 100                 | 27.8  | V <sub>k</sub> | 4.5     | 3.0     | 2.2     | 1.8     | 1.5     | 1.1     |         |
|                     |       | X              | 1.8     | 1.5     | 1.3     | 1.2     | 1.1     | 0.9     |         |
|                     |       | P <sub>t</sub> | 85      | 33      | 21      | 14      | 10      | 6       |         |
|                     |       | NR             | 36      | 29      | 25      | 21      | <20     | <20     |         |
| 140                 | 38.9  | V <sub>k</sub> | 3.3     | 4.2     | 3.1     | 2.5     | 2.1     | 1.6     | 1.3     |
|                     |       | X              | 2.6     | 2.1     | 1.8     | 1.6     | 1.5     | 1.3     | 1.1     |
|                     |       | P <sub>t</sub> | 166     | 65      | 42      | 27      | 20      | 12      | 7       |
|                     |       | NR             | 46      | 39      | 35      | 41      | 28      | 24      | 20      |
| 180                 | 50.0  | V <sub>k</sub> |         | 5.4     | 4.0     | 3.2     | 2.7     | 2.0     | 1.6     |
|                     |       | X              |         | 2.7     | 2.3     | 2.1     | 1.9     | 1.6     | 1.5     |
|                     |       | P <sub>t</sub> |         | 108     | 69      | 44      | 32      | 20      | 11      |
|                     |       | NR             |         | 47      | 42      | 39      | 36      | 31      | 28      |
| 200                 | 55.6  | V <sub>k</sub> |         | 6.0     | 4.5     | 3.6     | 3.0     | 2.2     | 1.8     |
|                     |       | X              |         | 3.0     | 2.6     | 2.3     | 2.1     | 1.8     | 1.6     |
|                     |       | P <sub>t</sub> |         | 133     | 85      | 54      | 40      | 24      | 14      |
|                     |       | NR             |         | 50      | 45      | 42      | 39      | 34      | 31      |
| 250                 | 69.4  | V <sub>k</sub> |         |         | 5.6     | 4.5     | 3.7     | 2.8     | 2.2     |
|                     |       | X              |         |         | 3.2     | 2.9     | 2.6     | 2.3     | 2.0     |
|                     |       | P <sub>t</sub> |         |         | 133     | 85      | 62      | 38      | 21      |
|                     |       | NR             |         |         | 52      | 49      | 46      | 41      | 38      |
| 300                 | 83.3  | V <sub>k</sub> |         |         |         | 5.4     | 4.5     | 3.4     | 2.7     |
|                     |       | X              |         |         |         | 3.5     | 3.2     | 2.7     | 2.4     |
|                     |       | P <sub>t</sub> |         |         |         | 122     | 90      | 54      | 31      |
|                     |       | NR             |         |         |         | 54      | 51      | 47      | 43      |
| 400                 | 111.1 | V <sub>k</sub> |         |         |         |         |         | 4.5     | 3.6     |
|                     |       | X              |         |         |         |         |         | 3.7     | 3.2     |
|                     |       | P <sub>t</sub> |         |         |         |         |         | 97      | 54      |
|                     |       | NR             |         |         |         |         |         | 55      | 52      |
| 500                 | 138.9 | V <sub>k</sub> |         |         |         |         |         |         | 4.5     |
|                     |       | X              |         |         |         |         |         |         | 4.0     |
|                     |       | P <sub>t</sub> |         |         |         |         |         |         | 85      |
|                     |       | NR             |         |         |         |         |         |         | 59      |

### Symbols:

A<sub>k</sub> - Effective area

V<sub>k</sub> - Effective velocity in m/s

X - Throw in metres correspond to a terminal velocity in occupied zone of 0.25m/s

Pressure (P<sub>t</sub>) - All pressures are in Pa (N/m<sup>2</sup>)

NR - Noise level index in dB based on a room absorption and one diffuser

# Linear Slot Diffuser 25

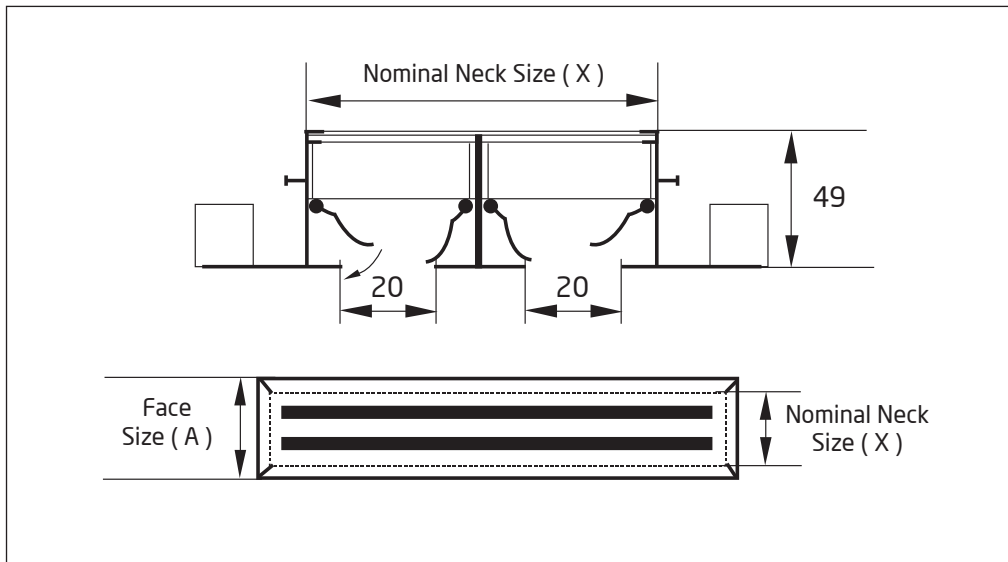

| No. of Slot | Nominal Neck Metric ( X ) | Face Size ( A ) |
|-------------|---------------------------|-----------------|
| 1 Slot      | 45 mm                     | 89 mm           |
| 2 Slots     | 86 mm                     | 130 mm          |
| 3 Slots     | 126 mm                    | 170 mm          |
| 4 Slots     | 167 mm                    | 211 mm          |
| 5 Slots     | 207 mm                    | 251 mm          |
| 6 Slots     | 248 mm                    | 292 mm          |

\* Grilles are powder coated white as standard

\* Length dimension can be modified based on different specification.

## Quick Selection Table

| Flow rate           |       | Dim.           | 600-1   | 900-1   | 1200-1  | 1500-1  | 900-2   | 1200-2  | 900-3   | 1500-2  | 1200-3  | 1500-3  | 1200-4  | 1500-4  |  |  |
|---------------------|-------|----------------|---------|---------|---------|---------|---------|---------|---------|---------|---------|---------|---------|---------|--|--|
| (m <sup>3</sup> /h) | (l/s) | A <sub>k</sub> | 0.00672 | 0.01007 | 0.01343 | 0.01679 | 0.02015 | 0.02687 | 0.03022 | 0.03358 | 0.04030 | 0.05037 | 0.05373 | 0.06716 |  |  |
|                     |       |                | 600-2   | 900-2   | 1200-2  | 1500-2  | 900-3   | 1200-3  | 900-4   | 1500-4  | 1200-3  | 1500-3  | 1200-4  | 1500-4  |  |  |
| 60                  | 16.7  | V <sub>k</sub> | 2.5     | 1.7     | 1.2     | 1.0     |         |         |         |         |         |         |         |         |  |  |
|                     |       | X              | 1.3     | 1.1     | 0.9     | 0.8     |         |         |         |         |         |         |         |         |  |  |
|                     |       | P <sub>t</sub> | 1.3     | 6       | 3       | 2       |         |         |         |         |         |         |         |         |  |  |
|                     |       | NR             | 27      | <20     | <20     | <20     |         |         |         |         |         |         |         |         |  |  |
| 80                  | 22.2  | V <sub>k</sub> | 3.3     | 2.2     | 21.7    | 1.3     | 1.1     |         |         |         |         |         |         |         |  |  |
|                     |       | X              | 1.7     | 1.4     | 1.2     | 1.1     | 1.0     |         |         |         |         |         |         |         |  |  |
|                     |       | P <sub>t</sub> | 23      | 10      | 6       | 4       | 3       |         |         |         |         |         |         |         |  |  |
|                     |       | NR             | 34      | 26      | 20      | <20     | <20     |         |         |         |         |         |         |         |  |  |
| 100                 | 27.8  | V <sub>k</sub> | 4.1     | 2.8     | 2.1     | 1.7     | 1.4     | 1.0     |         |         |         |         |         |         |  |  |
|                     |       | X              | 2.2     | 1.8     | 1.5     | 1.4     | 1.3     | 1.1     |         |         |         |         |         |         |  |  |
|                     |       | P <sub>t</sub> | 37      | 16      | 9       | 6       | 4       | 2       |         |         |         |         |         |         |  |  |
|                     |       | NR             | 39      | 31      | 26      | 22      | <20     | <20     |         |         |         |         |         |         |  |  |
| 140                 | 38.9  | V <sub>k</sub> | 5.8     | 3.9     | 2.9     | 2.3     | 1.9     | 1.4     | 1.3     | 1.2     | 1.0     |         |         |         |  |  |
|                     |       | X              | 3.0     | 2.5     | 2.1     | 1.9     | 1.8     | 1.5     | 1.4     | 1.4     | 1.2     |         |         |         |  |  |
|                     |       | P <sub>t</sub> | 72      | 32      | 18      | 11      | 8       | 4       | 3       | 3       | 2       |         |         |         |  |  |
|                     |       | NR             | 47      | 39      | 34      | 30      | 27      | 20      | <20     | <20     | <20     |         |         |         |  |  |
| 180                 | 50.0  | V <sub>k</sub> |         | 5.0     | 3.7     | 3.0     | 2.5     | 1.9     | 1.7     | 1.5     | 1.2     | 1.0     |         |         |  |  |
|                     |       | X              |         | 3.2     | 2.8     | 2.5     | 2.3     | 2.0     | 1.8     | 1.7     | 1.6     | 1.4     |         |         |  |  |
|                     |       | P <sub>t</sub> |         | 53      | 30      | 19      | 13      | 7       | 6       | 5       | 3       | 2       |         |         |  |  |
|                     |       | NR             |         | 45      | 40      | 36      | 33      | 27      | 24      | 22      | <20     | <20     |         |         |  |  |
| 200                 | 55.6  | V <sub>k</sub> |         | 5.5     | 4.1     | 3.3     | 2.8     | 2.1     | 1.8     | 1.7     | 1.4     | 1.1     | 1.0     |         |  |  |
|                     |       | X              |         | 3.5     | 3.1     | 2.7     | 2.5     | 2.2     | 2.0     | 1.9     | 1.8     | 1.6     | 1.5     |         |  |  |
|                     |       | P <sub>t</sub> |         | 65      | 37      | 23      | 16      | 9       | 7       | 6       | 4       | 3       | 2       |         |  |  |
|                     |       | NR             |         | 48      | 43      | 39      | 35      | 29      | 26      | 24      | 20      | <20     | <20     |         |  |  |
| 250                 | 69.4  | V <sub>k</sub> |         |         | 5.2     | 4.1     | 3.4     | 2.6     | 2.3     | 2.1     | 1.7     | 1.4     | 1.3     | 1.0     |  |  |
|                     |       | X              |         |         | 3.8     | 3.4     | 3.1     | 2.7     | 2.6     | 2.4     | 2.2     | 2.0     | 1.9     | 1.7     |  |  |
|                     |       | P <sub>t</sub> |         |         | 57      | 37      | 25      | 14      | 11      | 9       | 6       | 4       | 4       | 2       |  |  |
|                     |       | NR             |         |         | 48      | 44      | 41      | 34      | 32      | 29      | 25      | 21      | <20     | <20     |  |  |
| 300                 | 83.3  | V <sub>k</sub> |         |         | 6.2     | 5.0     | 4.1     | 3.1     | 2.8     | 2.5     | 2.1     | 1.7     | 1.6     | 1.2     |  |  |
|                     |       | X              |         |         | 4.6     | 4.1     | 3.8     | 3.3     | 3.1     | 2.9     | 2.7     | 2.4     | 2.3     | 2.1     |  |  |
|                     |       | P <sub>t</sub> |         |         | 82      | 53      | 37      | 21      | 16      | 13      | 9       | 6       | 5       | 3       |  |  |
|                     |       | NR             |         |         | 52      | 48      | 45      | 39      | 36      | 34      | 30      | 26      | 23      | <20     |  |  |
| 400                 | 111.1 | V <sub>k</sub> |         |         |         | 6.6     | 5.5     | 4.1     | 3.7     | 3.3     | 2.8     | 2.2     | 2.1     | 1.7     |  |  |
|                     |       | X              |         |         |         | 5.5     | 5.0     | 4.3     | 4.1     | 3.9     | 3.5     | 3.2     | 3.1     | 2.7     |  |  |
|                     |       | P <sub>t</sub> |         |         |         | 94      | 65      | 37      | 29      | 23      | 16      | 10      | 9       | 6       |  |  |
|                     |       | NR             |         |         |         | 55      | 52      | 46      | 43      | 41      | 37      | 33      | 30      | 25      |  |  |
| 500                 | 138.9 | V <sub>k</sub> |         |         |         |         |         | 5.2     | 4.6     | 4.1     | 3.4     | 2.8     | 2.6     | 2.1     |  |  |
|                     |       | X              |         |         |         |         |         | 5.4     | 5.1     | 4.8     | 4.4     | 4.0     | 3.8     | 3.4     |  |  |
|                     |       | P <sub>t</sub> |         |         |         |         |         | 57      | 45      | 37      | 25      | 16      | 14      | 9       |  |  |
|                     |       | NR             |         |         |         |         |         | 51      | 49      | 46      | 42      | 38      | 36      | 31      |  |  |
| 600                 | 166.7 | V <sub>k</sub> |         |         |         |         |         |         | 5.5     | 5.0     | 4.1     | 3.3     | 3.1     | 2.5     |  |  |
|                     |       | X              |         |         |         |         |         |         | 6.1     | 5.8     | 5.3     | 4.7     | 4.6     | 4.1     |  |  |
|                     |       | P <sub>t</sub> |         |         |         |         |         |         | 65      | 53      | 37      | 23      | 21      | 13      |  |  |
|                     |       | NR             |         |         |         |         |         |         | 53      | 51      | 47      | 43      | 40      | 35      |  |  |
| 700                 | 194.4 | V <sub>k</sub> |         |         |         |         |         |         |         | 5.8     | 4.8     | 3.9     | 3.6     | 2.9     |  |  |
|                     |       | X              |         |         |         |         |         |         | 6.8     | 6.2     | 5.5     | 5.4     | 4.8     |         |  |  |
|                     |       | P <sub>t</sub> |         |         |         |         |         |         | 72      | 50      | 32      | 28      | 18      |         |  |  |
|                     |       | NR             |         |         |         |         |         |         | 54      | 50      | 46      | 44      | 39      |         |  |  |
| 800                 | 222.2 | V <sub>k</sub> |         |         |         |         |         |         |         |         | 5.5     | 4.4     | 4.1     | 3.3     |  |  |
|                     |       | X              |         |         |         |         |         |         |         |         | 7.1     | 6.3     | 6.1     | 5.5     |  |  |
|                     |       | P <sub>t</sub> |         |         |         |         |         |         |         |         | 65      | 42      | 37      | 23      |  |  |
|                     |       | NR             |         |         |         |         |         |         |         |         | 54      | 50      | 47      | 42      |  |  |
| 900                 | 250.0 | V <sub>k</sub> |         |         |         |         |         |         |         |         |         | 5.0     | 4.7     | 3.7     |  |  |
|                     |       | X              |         |         |         |         |         |         |         |         |         | 7.1     | 6.9     | 6.2     |  |  |
|                     |       | P <sub>t</sub> |         |         |         |         |         |         |         |         |         | 53      | 46      | 30      |  |  |
|                     |       | NR             |         |         |         |         |         |         |         |         |         | 52      | 50      | 45      |  |  |
| 1000                | 277.8 | V <sub>k</sub> |         |         |         |         |         |         |         |         |         |         | 5.2     | 4.1     |  |  |
|                     |       | X              |         |         |         |         |         |         |         |         |         |         | 7.7     | 6.9     |  |  |
|                     |       | P <sub>t</sub> |         |         |         |         |         |         |         |         |         |         | 57      | 37      |  |  |
|                     |       | NR             |         |         |         |         |         |         |         |         |         |         | 53      | 48      |  |  |
| 1200                | 333.3 | V <sub>k</sub> |         |         |         |         |         |         |         |         |         |         |         | 5.0     |  |  |
|                     |       | X              |         |         |         |         |         |         |         |         |         |         |         | 8.2     |  |  |
|                     |       | P <sub>t</sub> |         |         |         |         |         |         |         |         |         |         |         | 53      |  |  |
|                     |       | NR             |         |         |         |         |         |         |         |         |         |         |         | 52      |  |  |

**Symbols:**

A<sub>k</sub> - Effective area

V<sub>k</sub> - Effective velocity in m/s

X - Throw in metres correspond to a terminal velocity in occupied zone of 0.25m/s

Pressure (P<sub>t</sub>) - All pressures are in Pa (N/m<sup>2</sup>)

NR - Noise level index in dB based on a room absorption and one diffuser

Quick Selection Table

| Flow rate           |       | Dim.           | 600-1   | 900-1   | 1200-1  | 1500-1  | 900-2   | 1200-2  | 900-3   | 1500-2  | 1200-3  | 1500-3  | 1200-4  | 1500-4  |    |
|---------------------|-------|----------------|---------|---------|---------|---------|---------|---------|---------|---------|---------|---------|---------|---------|----|
| (m <sup>3</sup> /h) | (l/s) | A <sub>k</sub> | 0.00701 | 0.01052 | 0.01402 | 0.01753 | 0.02104 | 0.02805 | 0.03156 | 0.03506 | 0.04207 | 0.05259 | 0.05610 | 0.07012 |    |
|                     |       |                |         |         | 600-2   | 1500-1  | 600-3   | 600-4   |         |         | 900-4   |         |         |         |    |
| 60                  | 16.7  | V <sub>k</sub> | 2.4     | 1.6     | 1.2     | 1.0     |         |         |         |         |         |         |         |         |    |
|                     |       | X              | 1.1     | 0.9     | 0.7     | 0.7     |         |         |         |         |         |         |         |         |    |
|                     |       | P <sub>t</sub> | 13      | 6       | 3       | 2       |         |         |         |         |         |         |         |         |    |
|                     |       | NR             | 26      | <20     | <20     | <20     |         |         |         |         |         |         |         |         |    |
| 80                  | 22.2  | V <sub>k</sub> | 3.2     | 2.1     | 1.6     | 1.3     | 1.1     |         |         |         |         |         |         |         |    |
|                     |       | X              | 1.4     | 1.1     | 1.0     | 0.9     | 0.8     |         |         |         |         |         |         |         |    |
|                     |       | P <sub>t</sub> | 22      | 10      | 6       | 4       | 2       |         |         |         |         |         |         |         |    |
|                     |       | NR             | 33      | 24      | <20     | <20     | <20     |         |         |         |         |         |         |         |    |
| 100                 | 27.8  | V <sub>k</sub> | 4.0     | 2.6     | 2.0     | 1.6     | 1.3     | 1.0     |         |         |         |         |         |         |    |
|                     |       | X              | 1.8     | 1.4     | 1.2     | 1.1     | 1.0     | 0.9     |         |         |         |         |         |         |    |
|                     |       | P <sub>t</sub> | 35      | 16      | 9       | 6       | 4       | 2       |         |         |         |         |         |         |    |
|                     |       | NR             | 38      | 29      | 23      | <20     | <20     | <20     |         |         |         |         |         |         |    |
| 140                 | 38.9  | V <sub>k</sub> | 5.5     | 3.7     | 2.8     | 2.2     | 1.8     | 1.4     | 1.2     | 1.1     |         |         |         |         |    |
|                     |       | X              | 2.5     | 2.0     | 1.7     | 1.6     | 1.4     | 1.2     | 1.2     | 1.1     |         |         |         |         |    |
|                     |       | P <sub>t</sub> | 69      | 30      | 17      | 11      | 8       | 4       | 3       | 3       |         |         |         |         |    |
|                     |       | NR             | 46      | 37      | 31      | 26      | 22      | <20     | <20     | <20     |         |         |         |         |    |
| 180                 | 50.0  | V <sub>k</sub> |         | 4.8     | 3.6     | 2.9     | 2.4     | 1.8     | 1.6     | 1.4     | 1.2     | 1.0     |         |         |    |
|                     |       | X              |         | 2.6     | 2.2     | 2.0     | 1.8     | 1.6     | 1.5     | 1.4     | 1.3     | 1.2     |         |         |    |
|                     |       | P <sub>t</sub> |         | 50      | 28      | 18      | 13      | 7       | 6       | 5       | 3       | 2       |         |         |    |
|                     |       | NR             |         | 43      | 37      | 32      | 28      | 21      | <20     | <20     | <20     | <20     |         |         |    |
| 200                 | 55.6  | V <sub>k</sub> |         | 5.3     | 4.0     | 3.2     | 2.6     | 2.0     | 1.8     | 1.4     | 1.3     | 1.1     | 1.0     |         |    |
|                     |       | X              |         | 2.9     | 2.5     | 2.2     | 2.0     | 1.8     | 1.7     | 1.4     | 1.4     | 1.3     | 1.2     |         |    |
|                     |       | P <sub>t</sub> |         | 62      | 35      | 22      | 16      | 9       | 7       | 5       | 4       | 2       | 2       |         |    |
|                     |       | NR             |         | 46      | 40      | 34      | 30      | 24      | 21      | <20     | <20     | <20     | <20     |         |    |
| 250                 | 69.4  | V <sub>k</sub> |         |         | 5.0     | 4.0     | 3.3     | 2.5     | 2.2     | 2.0     | 1.7     | 1.3     | 1.2     |         |    |
|                     |       | X              |         |         | 3.1     | 2.8     | 2.5     | 2.2     | 2.1     | 2.0     | 1.8     | 1.6     | 1.5     |         |    |
|                     |       | P <sub>t</sub> |         |         | 55      | 35      | 24      | 14      | 11      | 9       | 6       | 4       | 3       |         |    |
|                     |       | NR             |         |         | 45      | 40      | 36      | 29      | 27      | 24      | 20      | <20     | <20     |         |    |
| 300                 | 83.3  | V <sub>k</sub> |         |         | 5.9     | 4.8     | 4.0     | 3.0     | 2.6     | 2.4     | 2.0     | 1.6     | 1.5     | 1.2     |    |
|                     |       | X              |         |         | 3.7     | 3.3     | 3.0     | 2.6     | 2.5     | 2.3     | 2.1     | 1.9     | 1.9     | 1.7     |    |
|                     |       | P <sub>t</sub> |         |         | 79      | 50      | 35      | 20      | 16      | 13      | 9       | 6       | 5       | 3       |    |
|                     |       | NR             |         |         | 49      | 44      | 40      | 34      | 31      | 29      | 25      | 20      | <20     | <20     |    |
| 400                 | 111.1 | V <sub>k</sub> |         |         |         | 6.3     | 5.3     | 4.0     | 3.5     | 3.2     | 2.6     | 2.1     | 2.0     | 1.6     |    |
|                     |       | X              |         |         |         | 4.4     | 4.0     | 3.5     | 3.3     | 3.1     | 2.9     | 2.6     | 2.5     | 2.2     |    |
|                     |       | P <sub>t</sub> |         |         |         | 90      | 62      | 35      | 28      | 22      | 16      | 10      | 9       | 6       |    |
|                     |       | NR             |         |         |         | 51      | 47      | 41      | 38      | 36      | 32      | 27      | 25      | 20      |    |
| 500                 | 138.9 | V <sub>k</sub> |         |         |         |         |         | 5.0     | 4.4     | 4.0     | 3.3     | 2.6     | 2.5     | 2.0     |    |
|                     |       | X              |         |         |         |         |         | 4.4     | 4.1     | 3.9     | 3.6     | 3.2     | 3.1     | 2.8     |    |
|                     |       | P <sub>t</sub> |         |         |         |         |         | 55      | 43      | 35      | 24      | 16      | 14      | 9       |    |
|                     |       | NR             |         |         |         |         |         | 46      | 44      | 41      | 37      | 32      | 31      | 26      |    |
| 600                 | 166.7 | V <sub>k</sub> |         |         |         |         |         |         | 5.3     | 4.8     | 4.0     | 3.2     | 3.0     | 2.4     |    |
|                     |       | X              |         |         |         |         |         |         | 5.0     | 4.7     | 4.3     | 3.8     | 3.7     | 3.3     |    |
|                     |       | P <sub>t</sub> |         |         |         |         |         |         | 62      | 50      | 35      | 22      | 20      | 13      |    |
|                     |       | NR             |         |         |         |         |         |         | 48      | 46      | 42      | 37      | 35      | 30      |    |
| 700                 | 194.4 | V <sub>k</sub> |         |         |         |         |         |         |         | 5.5     | 4.6     | 3.7     | 3.5     | 2.8     |    |
|                     |       | X              |         |         |         |         |         |         |         | 5.5     | 5.0     | 4.5     | 4.3     | 3.9     |    |
|                     |       | P <sub>t</sub> |         |         |         |         |         |         |         |         | 69      | 48      | 30      | 27      | 17 |
|                     |       | NR             |         |         |         |         |         |         |         |         | 50      | 45      | 40      | 39      | 34 |
| 800                 | 222.2 | V <sub>k</sub> |         |         |         |         |         |         |         |         | 5.3     | 4.2     | 4.0     | 3.2     |    |
|                     |       | X              |         |         |         |         |         |         |         |         | 5.7     | 5.1     | 5.0     | 4.4     |    |
|                     |       | P <sub>t</sub> |         |         |         |         |         |         |         |         |         | 62      | 40      | 35      | 22 |
|                     |       | NR             |         |         |         |         |         |         |         |         |         | 49      | 44      | 44      | 37 |
| 900                 | 250.0 | V <sub>k</sub> |         |         |         |         |         |         |         |         |         | 4.8     | 4.5     | 3.6     |    |
|                     |       | X              |         |         |         |         |         |         |         |         |         | 5.8     | 5.0     | 5.0     |    |
|                     |       | P <sub>t</sub> |         |         |         |         |         |         |         |         |         | 50      | 6.2     | 28      |    |
|                     |       | NR             |         |         |         |         |         |         |         |         |         | 47      | 55      | 40      |    |
| 1000                | 277.8 | V <sub>k</sub> |         |         |         |         |         |         |         |         |         |         | 4.8     | 4.0     |    |
|                     |       | X              |         |         |         |         |         |         |         |         |         |         |         | 5.5     |    |
|                     |       | P <sub>t</sub> |         |         |         |         |         |         |         |         |         |         |         | 35      |    |
|                     |       | NR             |         |         |         |         |         |         |         |         |         |         |         | 43      |    |
| 1200                | 333.3 | V <sub>k</sub> |         |         |         |         |         |         |         |         |         |         |         | 4.8     |    |
|                     |       | X              |         |         |         |         |         |         |         |         |         |         |         | 6.6     |    |
|                     |       | P <sub>t</sub> |         |         |         |         |         |         |         |         |         |         |         | 50      |    |
|                     |       | NR             |         |         |         |         |         |         |         |         |         |         |         | 47      |    |

Symbols:

- A<sub>k</sub> - Effective area
- V<sub>k</sub> - Effective velocity in m/s
- X - Throw in metres correspond to a terminal velocity in occupied zone of 0.25m/s
- Pressure ( P<sub>t</sub> ) - All pressures are in Pa (N/m<sup>2</sup>)
- NR - Noise level index in dB based on a room absorption and one diffuser



## Linear Slot Diffuser Frame

### General Information:

The mounting frame is designed to allow a quick and simple installation alternative of diffusers and grilles in comparison to the conventional installation method.

The mounting frame also allows the diffuser or grille to be easily removed from the face side to allow access to services and other requirements, thus reducing the need for access panels.

### Features:

- Mounting frame makes slot grilles installation easy
- Size manufactured on request

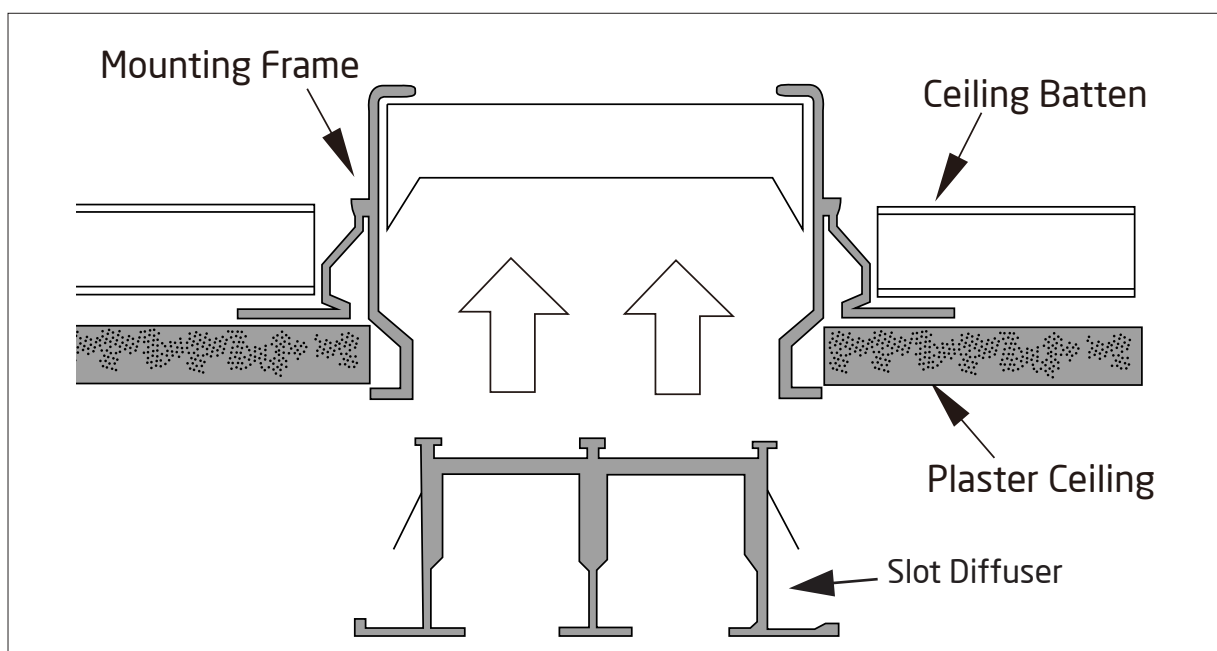

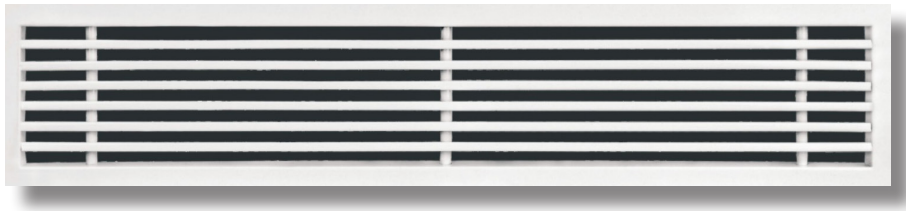

## Linear Bar Grille

### General Information:

All grilles, both with and without frames, can be manufactured with a hingeable access panel at one or both ends of the grille. The standard length of each panel piece is 150mm, although this length can be varied upon request.

Due to the large amount of possibilities offered by this type of grille, it is recommended to consult in specific cases with special dimensions.

This range of grille has the necessary characteristics for its integration in contemporary architecture and interior design. They can be installed in ceilings, walls, consoles, fan-coils, induction units, both for supply and return air application and, properly reinforced, in floors.

The maximum recommended length is 2m in one piece, although 2 or more modules can be combined to give appearance of continuity.

### Features:

- Made of extruded aluminium
- Fixed blades at 0 degree, 15 degree, 30 degree
- Rigid, heavy gauge extruded frames with reinforced mitered and welded corners
- Standard finish white, other finishes are available
- Surface mounting or concealed mounting
- Size manufactured on request
- Construction is of a fixed core, while a hinged core option is available

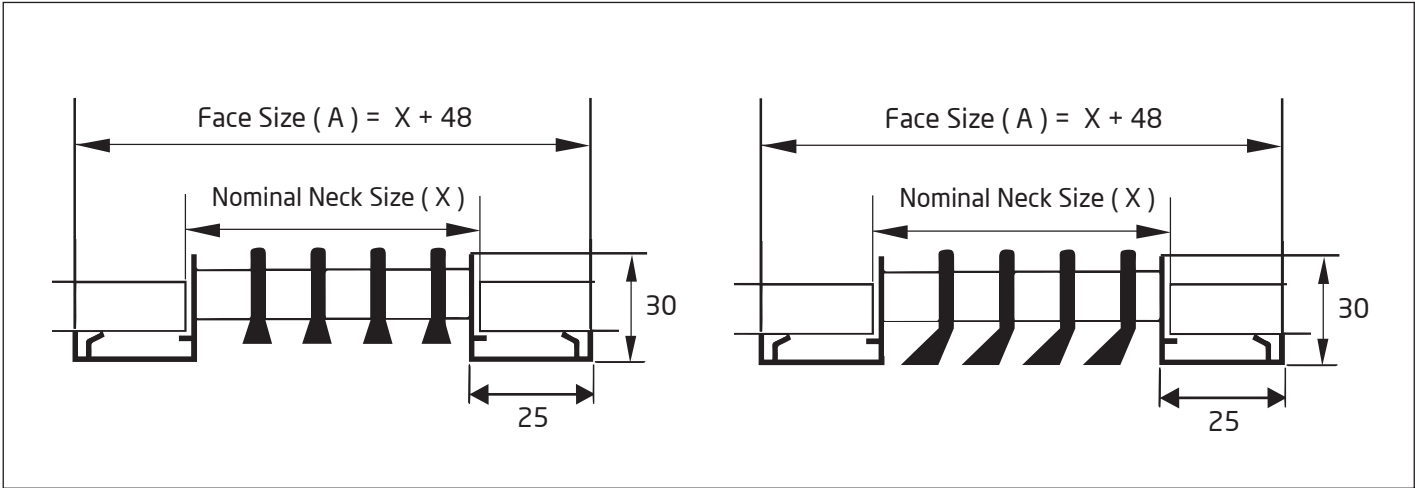

**General notes on the quick selection table:**

Apart from the before-mentioned factor  $C_s$  ( for grilles mounted in sill or floor ), another correction factor exists for the distance of the grille to the ceiling, when mounted in a wall. For a free jet this factor  $C_h$  will be 1.6.

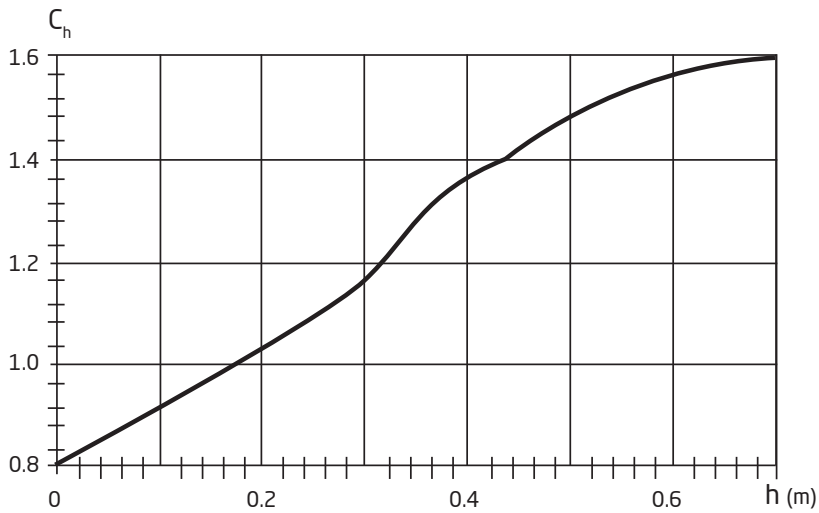

Corrected throw = Throw

$C_h$ , with h in the graph the distance between grille and ceiling.

$$X_c = X * C_h$$

**Quick Selection Table**

Symbols:

$A_x$  - Effective area

$V_k$  - Effective velocity in m/s

X - Throw in metres correspond to a terminal velocity in occupied zone of 0.25m/s

Pressure ( $P_t$ ) - All pressures are in Pa ( $N/m^2$ )

NR - Noise level index in dB based on a room absorption and one diffuser

| Flow rate           |       | L              | 1000  | 1000   | 1000   | 1000   | 1000   | 1000   | 1000   | 1000   |
|---------------------|-------|----------------|-------|--------|--------|--------|--------|--------|--------|--------|
|                     |       | H              | 50    | 75     | 100    | 125    | 150    | 200    | 250    | 300    |
| (m <sup>3</sup> /h) | (l/s) | A <sub>k</sub> | 0.024 | 0.0370 | 0.0500 | 0.0630 | 0.0820 | 0.1080 | 0.1400 | 0.1720 |
| 100                 | 27.8  | V <sub>k</sub> | 1.2   | 0.8    | 0.6    |        |        |        |        |        |
|                     |       | X              | 2.3   | 1.9    | 1.6    |        |        |        |        |        |
|                     |       | P <sub>t</sub> | 0.8   | 0.3    | 0.2    |        |        |        |        |        |
|                     |       | NR             | -     | -      | -      |        |        |        |        |        |
| 120                 | 33.3  | V <sub>k</sub> | 1.4   | 0.9    | 0.7    |        |        |        |        |        |
|                     |       | X              | 2.8   | 2.2    | 1.9    |        |        |        |        |        |
|                     |       | P <sub>t</sub> | 1.1   | 0.5    | 0.3    |        |        |        |        |        |
|                     |       | NR             | -     | -      | -      |        |        |        |        |        |
| 140                 | 38.9  | V <sub>k</sub> | 1.6   | 1.1    | 0.8    |        |        |        |        |        |
|                     |       | X              | 3.2   | 2.6    | 2.2    |        |        |        |        |        |
|                     |       | P <sub>t</sub> | 1.5   | 0.6    | 0.4    |        |        |        |        |        |
|                     |       | NR             | -     | -      | -      |        |        |        |        |        |
| 160                 | 44.4  | V <sub>k</sub> | 1.9   | 1.2    | 0.9    |        |        |        |        |        |
|                     |       | X              | 3.7   | 3.0    | 2.6    |        |        |        |        |        |
|                     |       | P <sub>t</sub> | 2.0   | 0.8    | 0.5    |        |        |        |        |        |
|                     |       | NR             | -     | -      | -      |        |        |        |        |        |
| 180                 | 50.0  | V <sub>k</sub> | 2.1   | 1.4    | 1.0    | 0.8    |        |        |        |        |
|                     |       | X              | 4.1   | 3.3    | 2.9    | 2.6    |        |        |        |        |
|                     |       | P <sub>t</sub> | 2.5   | 1.1    | 0.6    | 0.4    |        |        |        |        |
|                     |       | NR             | 8     | -      | -      | -      |        |        |        |        |
| 200                 | 55.6  | V <sub>k</sub> | 2.3   | 1.5    | 1.1    | 0.9    |        |        |        |        |
|                     |       | X              | 4.6   | 3.7    | 3.2    | 2.8    |        |        |        |        |
|                     |       | P <sub>t</sub> | 3.1   | 1.3    | 0.7    | 0.5    |        |        |        |        |
|                     |       | NR             | 10    | -      | -      | -      |        |        |        |        |
| 250                 | 69.4  | V <sub>k</sub> | 2.9   | 1.9    | 1.4    | 1.1    | 0.8    |        |        |        |
|                     |       | X              | 5.8   | 4.6    | 4.0    | 3.6    | 3.1    |        |        |        |
|                     |       | P <sub>t</sub> | 4.9   | 2.0    | 1.1    | 0.7    | 0.4    |        |        |        |
|                     |       | NR             | 16    | 7      | -      | -      | -      |        |        |        |
| 300                 | 83.3  | V <sub>k</sub> | 3.5   | 2.3    | 1.7    | 1.3    | 1.0    | 0.8    | 0.6    |        |
|                     |       | X              | 6.9   | 5.6    | 4.8    | 4.3    | 3.7    | 3.3    | 2.9    |        |
|                     |       | P <sub>t</sub> | 7.0   | 2.9    | 1.6    | 1.0    | 0.6    | 0.3    | 0.2    |        |
|                     |       | NR             | 21    | 11     | -      | -      | -      | -      | -      | -      |
| 350                 | 97.2  | V <sub>k</sub> | 4.1   | 2.6    | 1.9    | 1.5    | 1.2    | 0.9    | 0.7    | 0.6    |
|                     |       | X              | 8.1   | 6.5    | 5.6    | 5.0    | 4.4    | 3.8    | 3.3    | 3.0    |
|                     |       | P <sub>t</sub> | 9.5   | 4.0    | 2.2    | 1.4    | 0.8    | 0.5    | 0.3    | 0.2    |
|                     |       | NR             | 25    | 15     | 9      | -      | -      | -      | -      | -      |
| 400                 | 111.1 | V <sub>k</sub> | 4.6   | 3.0    | 2.2    | 1.8    | 1.4    | 1.0    | 0.8    | 0.6    |
|                     |       | X              | 9.2   | 7.4    | 6.4    | 5.7    | 5.0    | 4.3    | 3.8    | 3.4    |
|                     |       | P <sub>t</sub> | 12.4  | 5.2    | 2.9    | 1.8    | 1.1    | 0.6    | 0.4    | 0.2    |
|                     |       | NR             | 28    | 19     | 12     | 8      | -      | -      | -      | -      |
| 450                 | 125.0 | V <sub>k</sub> | 5.2   | 3.4    | 2.5    | 2.0    | 1.5    | 1.2    | 0.9    | 0.7    |
|                     |       | X              | 10.4  | 8.3    | 7.2    | 6.4    | 5.6    | 4.9    | 4.3    | 3.9    |
|                     |       | P <sub>t</sub> | 15.7  | 6.6    | 3.6    | 2.3    | 1.3    | 0.8    | 0.5    | 0.3    |
|                     |       | NR             | 31    | 22     | 15     | 11     | 5      | -      | -      | -      |
| 500                 | 138.9 | V <sub>k</sub> | 5.8   | 3.8    | 2.8    | 2.2    | 1.7    | 1.3    | 1.0    | 0.8    |
|                     |       | X              | 11.5  | 9.3    | 8.0    | 7.1    | 6.2    | 5.4    | 4.8    | 4.3    |
|                     |       | P <sub>t</sub> | 19.4  | 8.2    | 4.5    | 2.8    | 1.7    | 1.0    | 0.6    | 0.4    |
|                     |       | NR             | 34    | 25     | 18     | 13     | 8      | -      | -      | -      |
| 600                 | 166.7 | V <sub>k</sub> | 6.9   | 4.5    | 3.3    | 2.6    | 2.0    | 1.5    | 1.2    | 1.0    |
|                     |       | X              | 13.8  | 11.1   | 9.6    | 8.5    | 7.5    | 6.5    | 5.7    | 5.2    |
|                     |       | P <sub>t</sub> | 28.0  | 11.8   | 6.4    | 4.1    | 2.4    | 1.4    | 0.8    | 0.5    |
|                     |       | NR             | 38    | 29     | 23     | 18     | 12     | 6      | -      | -      |
| 700                 | 194.4 | V <sub>k</sub> | 8.1   | 5.3    | 3.9    | 3.1    | 2.4    | 1.8    | 1.4    | 1.1    |
|                     |       | X              | 16.1  | 13.0   | 11.2   | 9.9    | 8.7    | 7.6    | 6.7    | 6.0    |
|                     |       | P <sub>t</sub> | 38.1  | 16.0   | 8.8    | 5.5    | 3.3    | 1.9    | 1.1    | 0.7    |
|                     |       | NR             | 42    | 33     | 27     | 22     | 16     | 10     | 5      | -      |
| 800                 | 222.2 | V <sub>k</sub> | 9.3   | 6.0    | 4.4    | 3.5    | 2.7    | 2.1    | 1.6    | 1.3    |
|                     |       | X              | 18.4  | 14.8   | 12.8   | 11.4   | 10.0   | 8.7    | 7.6    | 6.9    |
|                     |       | P <sub>t</sub> | 49.7  | 20.9   | 11.5   | 7.2    | 4.3    | 2.5    | 1.5    | 1.0    |
|                     |       | NR             | 46    | 37     | 30     | 25     | 20     | 14     | 8      | -      |
| 900                 | 250.0 | V <sub>k</sub> |       | 6.8    | 5.0    | 4.0    | 3.0    | 2.3    | 1.8    | 1.5    |
|                     |       | X              |       | 16.7   | 14.4   | 12.8   | 11.2   | 9.8    | 8.6    | 7.7    |
|                     |       | P <sub>t</sub> |       | 26.5   | 14.5   | 9.1    | 5.4    | 3.1    | 1.8    | 1.2    |
|                     |       | NR             |       | 40     | 33     | 28     | 23     | 17     | 11     | 7      |
| 1000                | 277.8 | V <sub>k</sub> |       | 7.5    | 5.6    | 4.4    | 3.4    | 2.6    | 2.0    | 1.6    |
|                     |       | X              |       | 18.5   | 15.9   | 14.2   | 12.5   | 10.9   | 9.5    | 8.6    |
|                     |       | P <sub>t</sub> |       | 32.7   | 17.9   | 11.3   | 6.7    | 3.8    | 2.3    | 1.5    |
|                     |       | NR             |       | 42     | 36     | 31     | 25     | 20     | 14     | 10     |
| 1200                | 333.3 | V <sub>k</sub> |       |        | 6.7    | 5.3    | 4.1    | 3.1    | 2.4    | 1.9    |
|                     |       | X              |       |        | 19.1   | 17.1   | 14.9   | 13.0   | 11.4   | 10.3   |
|                     |       | P <sub>t</sub> |       |        | 25.8   | 16.2   | 9.6    | 5.5    | 3.3    | 2.2    |
|                     |       | NR             |       |        | 41     | 36     | 30     | 24     | 19     | 14     |
| 1400                | 388.9 | V <sub>k</sub> |       |        |        | 6.2    | 4.7    | 3.6    | 2.8    | 2.3    |
|                     |       | X              |       |        |        | 19.9   | 17.4   | 15.2   | 13.3   | 12.0   |
|                     |       | P <sub>t</sub> |       |        |        | 22.1   | 13.0   | 7.5    | 4.5    | 3.0    |
|                     |       | NR             |       |        |        | 40     | 34     | 28     | 23     | 18     |



# Flangeless Linear Bar Grille

## General Information:

All grilles, both with and without frames, can be manufactured with a hingeable access panel at one or both ends of the grille. The standard length of each panel piece is 150mm, although this length can be varied upon request.

Due to the large amount of possibilities offered by this type of grille, it is recommended to consult in specific cases with special dimensions.

This range of grille has the necessary characteristics for its integration in contemporary architecture and interior design. They can be installed in ceilings, walls, consoles, fan-coils, induction units, both for supply and return air application and, properly reinforced, in floors.

The maximum recommended length is 2m in one piece, although 2 or more modules can be combined so as to give appearance of continuity.

Flangeless versions are also available but note that alters the neck and face dimensions slightly. Also available on request are easy installation of plasterboard mounting frames.

## Features:

- Made of extruded aluminium
- Fixed blades at 0 degree, 15 degree, 30 degree
- Rigid, heavy gauge extruded frames with reinforced mitered and welded corners
- Standard finish white, other finishes are available
- Surface mounting or concealed mounting
- Size manufactured on request
- Construction is of a fixed core, while a hinged core option is available

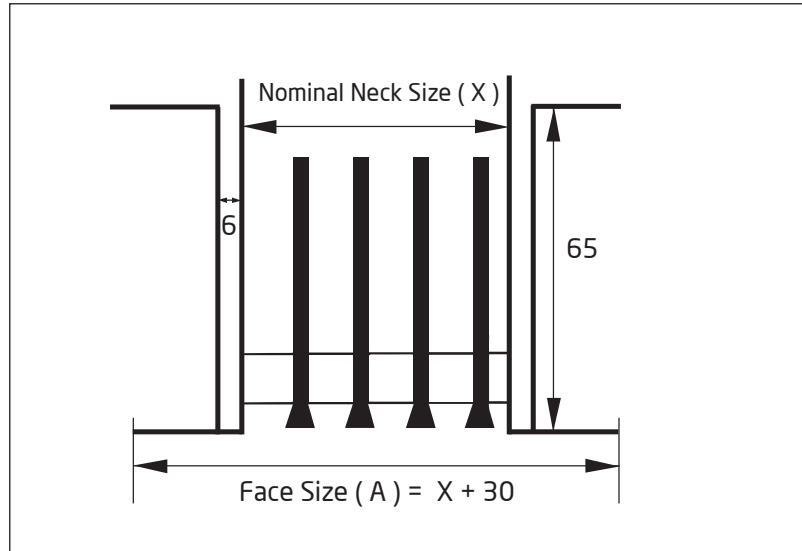

**General notes on the quick selection table:**

Apart from the before-mentioned factor  $C_s$  ( for grilles mounted in sill or floor ), another correction factor exists for the distance of the grille to the ceiling, when mounted in a wall. For a free jet this factor  $C_h$  will be 1.6.

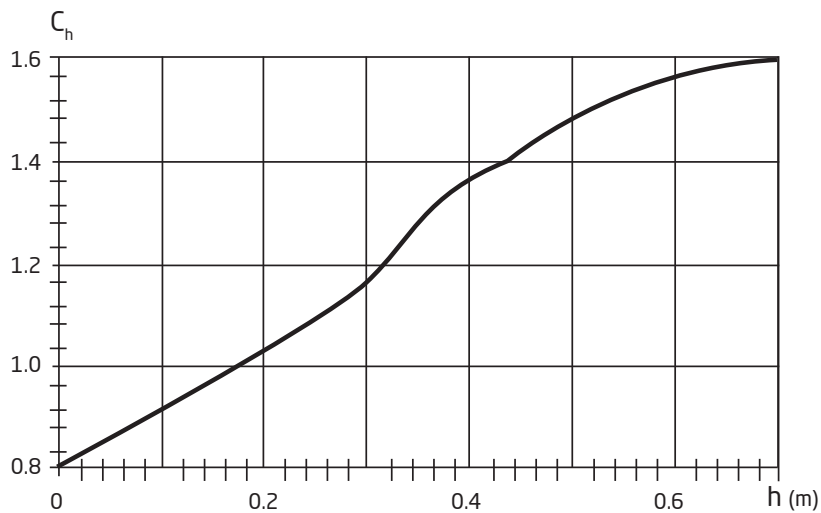

Corrected throw = Throw

$C_h$ , with h in the graph the distance between grille and ceiling.

$$X_c = X * C_h$$

**Quick Selection Table**

Symbols:

$A_x$  - Effective area

$V_k$  - Effective velocity in m/s

X - Throw in metres correspond to a terminal velocity in occupied zone of 0.25m/s

Pressure ( $P_t$ ) - All pressures are in Pa (N/m<sup>2</sup>)

NR - Noise level index in dB based on a room absorption and one diffuser

# Supply Air Grille

| Flow rate |       | L              | 1000  | 1000   | 1000   | 1000   | 1000   | 1000   | 1000   | 1000   |   |
|-----------|-------|----------------|-------|--------|--------|--------|--------|--------|--------|--------|---|
|           |       | H              | 50    | 75     | 100    | 125    | 150    | 200    | 250    | 300    |   |
| (m³/h)    | (l/s) | A <sub>k</sub> | 0.024 | 0.0370 | 0.0500 | 0.0630 | 0.0820 | 0.1080 | 0.1400 | 0.1720 |   |
| 100       | 27.8  | V <sub>k</sub> | 1.2   | 0.8    | 0.6    |        |        |        |        |        |   |
|           |       | X              | 2.3   | 1.9    | 1.6    |        |        |        |        |        |   |
|           |       | P <sub>t</sub> | 0.8   | 0.3    | 0.2    |        |        |        |        |        |   |
|           |       | NR             | -     | -      | -      |        |        |        |        |        |   |
| 120       | 33.3  | V <sub>k</sub> | 1.4   | 0.9    | 0.7    |        |        |        |        |        |   |
|           |       | X              | 2.8   | 2.2    | 1.9    |        |        |        |        |        |   |
|           |       | P <sub>t</sub> | 1.1   | 0.5    | 0.3    |        |        |        |        |        |   |
|           |       | NR             | -     | -      | -      |        |        |        |        |        |   |
| 140       | 38.9  | V <sub>k</sub> | 1.6   | 1.1    | 0.8    |        |        |        |        |        |   |
|           |       | X              | 3.2   | 2.6    | 2.2    |        |        |        |        |        |   |
|           |       | P <sub>t</sub> | 1.5   | 0.6    | 0.4    |        |        |        |        |        |   |
|           |       | NR             | -     | -      | -      |        |        |        |        |        |   |
| 160       | 44.4  | V <sub>k</sub> | 1.9   | 1.2    | 0.9    |        |        |        |        |        |   |
|           |       | X              | 3.7   | 3.0    | 2.6    |        |        |        |        |        |   |
|           |       | P <sub>t</sub> | 2.0   | 0.8    | 0.5    |        |        |        |        |        |   |
|           |       | NR             | -     | -      | -      |        |        |        |        |        |   |
| 180       | 50.0  | V <sub>k</sub> | 2.1   | 1.4    | 1.0    | 0.8    |        |        |        |        |   |
|           |       | X              | 4.1   | 3.3    | 2.9    | 2.6    |        |        |        |        |   |
|           |       | P <sub>t</sub> | 2.5   | 1.1    | 0.6    | 0.4    |        |        |        |        |   |
|           |       | NR             | 8     | -      | -      | -      |        |        |        |        |   |
| 200       | 55.6  | V <sub>k</sub> | 2.3   | 1.5    | 1.1    | 0.9    |        |        |        |        |   |
|           |       | X              | 4.6   | 3.7    | 3.2    | 2.8    |        |        |        |        |   |
|           |       | P <sub>t</sub> | 3.1   | 1.3    | 0.7    | 0.5    |        |        |        |        |   |
|           |       | NR             | 10    | -      | -      | -      |        |        |        |        |   |
| 250       | 69.4  | V <sub>k</sub> | 2.9   | 1.9    | 1.4    | 1.1    | 0.8    |        |        |        |   |
|           |       | X              | 5.8   | 4.6    | 4.0    | 3.6    | 3.1    |        |        |        |   |
|           |       | P <sub>t</sub> | 4.9   | 2.0    | 1.1    | 0.7    | 0.4    |        |        |        |   |
|           |       | NR             | 16    | 7      | -      | -      | -      |        |        |        |   |
| 300       | 83.3  | V <sub>k</sub> | 3.5   | 2.3    | 1.7    | 1.3    | 1.0    | 0.8    | 0.6    |        |   |
|           |       | X              | 6.9   | 5.6    | 4.8    | 4.3    | 3.7    | 3.3    | 2.9    |        |   |
|           |       | P <sub>t</sub> | 7.0   | 2.9    | 1.6    | 1.0    | 0.6    | 0.3    | 0.2    |        |   |
|           |       | NR             | 21    | 11     | -      | -      | -      | -      | -      | -      |   |
| 350       | 97.2  | V <sub>k</sub> | 4.1   | 2.6    | 1.9    | 1.5    | 1.2    | 0.9    | 0.7    | 0.6    |   |
|           |       | X              | 8.1   | 6.5    | 5.6    | 5.0    | 4.4    | 3.8    | 3.3    | 3.0    |   |
|           |       | P <sub>t</sub> | 9.5   | 4.0    | 2.2    | 1.4    | 0.8    | 0.5    | 0.3    | 0.2    |   |
|           |       | NR             | 25    | 15     | 9      | -      | -      | -      | -      | -      | - |
| 400       | 111.1 | V <sub>k</sub> | 4.6   | 3.0    | 2.2    | 1.8    | 1.4    | 1.0    | 0.8    | 0.6    |   |
|           |       | X              | 9.2   | 7.4    | 6.4    | 5.7    | 5.0    | 4.3    | 3.8    | 3.4    |   |
|           |       | P <sub>t</sub> | 12.4  | 5.2    | 2.9    | 1.8    | 1.1    | 0.6    | 0.4    | 0.2    |   |
|           |       | NR             | 28    | 19     | 12     | 8      | -      | -      | -      | -      | - |
| 450       | 125.0 | V <sub>k</sub> | 5.2   | 3.4    | 2.5    | 2.0    | 1.5    | 1.2    | 0.9    | 0.7    |   |
|           |       | X              | 10.4  | 8.3    | 7.2    | 6.4    | 5.6    | 4.9    | 4.3    | 3.9    |   |
|           |       | P <sub>t</sub> | 15.7  | 6.6    | 3.6    | 2.3    | 1.3    | 0.8    | 0.5    | 0.3    |   |
|           |       | NR             | 31    | 22     | 15     | 11     | 5      | -      | -      | -      | - |
| 500       | 138.9 | V <sub>k</sub> | 5.8   | 3.8    | 2.8    | 2.2    | 1.7    | 1.3    | 1.0    | 0.8    |   |
|           |       | X              | 11.5  | 9.3    | 8.0    | 7.1    | 6.2    | 5.4    | 4.8    | 4.3    |   |
|           |       | P <sub>t</sub> | 19.4  | 8.2    | 4.5    | 2.8    | 1.7    | 1.0    | 0.6    | 0.4    |   |
|           |       | NR             | 34    | 25     | 18     | 13     | 8      | -      | -      | -      | - |
| 600       | 166.7 | V <sub>k</sub> | 6.9   | 4.5    | 3.3    | 2.6    | 2.0    | 1.5    | 1.2    | 1.0    |   |
|           |       | X              | 13.8  | 11.1   | 9.6    | 8.5    | 7.5    | 6.5    | 5.7    | 5.2    |   |
|           |       | P <sub>t</sub> | 28.0  | 11.8   | 6.4    | 4.1    | 2.4    | 1.4    | 0.8    | 0.5    |   |
|           |       | NR             | 38    | 29     | 23     | 18     | 12     | 6      | -      | -      | - |
| 700       | 194.4 | V <sub>k</sub> | 8.1   | 5.3    | 3.9    | 3.1    | 2.4    | 1.8    | 1.4    | 1.1    |   |
|           |       | X              | 16.1  | 13.0   | 11.2   | 9.9    | 8.7    | 7.6    | 6.7    | 6.0    |   |
|           |       | P <sub>t</sub> | 38.1  | 16.0   | 8.8    | 5.5    | 3.3    | 1.9    | 1.1    | 0.7    |   |
|           |       | NR             | 42    | 33     | 27     | 22     | 16     | 10     | 5      | -      | - |
| 800       | 222.2 | V <sub>k</sub> | 9.3   | 6.0    | 4.4    | 3.5    | 2.7    | 2.1    | 1.6    | 1.3    |   |
|           |       | X              | 18.4  | 14.8   | 12.8   | 11.4   | 10.0   | 8.7    | 7.6    | 6.9    |   |
|           |       | P <sub>t</sub> | 49.7  | 20.9   | 11.5   | 7.2    | 4.3    | 2.5    | 1.5    | 1.0    |   |
|           |       | NR             | 46    | 37     | 30     | 25     | 20     | 14     | 8      | -      | - |
| 900       | 250.0 | V <sub>k</sub> |       | 6.8    | 5.0    | 4.0    | 3.0    | 2.3    | 1.8    | 1.5    |   |
|           |       | X              |       | 16.7   | 14.4   | 12.8   | 11.2   | 9.8    | 8.6    | 7.7    |   |
|           |       | P <sub>t</sub> |       | 26.5   | 14.5   | 9.1    | 5.4    | 3.1    | 1.8    | 1.2    |   |
|           |       | NR             |       | 40     | 33     | 28     | 23     | 17     | 11     | 7      |   |
| 1000      | 277.8 | V <sub>k</sub> |       | 7.5    | 5.6    | 4.4    | 3.4    | 2.6    | 2.0    | 1.6    |   |
|           |       | X              |       | 18.5   | 15.9   | 14.2   | 12.5   | 10.9   | 9.5    | 8.6    |   |
|           |       | P <sub>t</sub> |       | 32.7   | 17.9   | 11.3   | 6.7    | 3.8    | 2.3    | 1.5    |   |
|           |       | NR             |       | 42     | 36     | 31     | 25     | 20     | 14     | 10     |   |
| 1200      | 333.3 | V <sub>k</sub> |       |        | 6.7    | 5.3    | 4.1    | 3.1    | 2.4    | 1.9    |   |
|           |       | X              |       |        | 19.1   | 17.1   | 14.9   | 13.0   | 11.4   | 10.3   |   |
|           |       | P <sub>t</sub> |       |        | 25.8   | 16.2   | 9.6    | 5.5    | 3.3    | 2.2    |   |
|           |       | NR             |       |        | 41     | 36     | 30     | 24     | 19     | 14     |   |
| 1400      | 388.9 | V <sub>k</sub> |       |        |        | 6.2    | 4.7    | 3.6    | 2.8    | 2.3    |   |
|           |       | X              |       |        |        | 19.9   | 17.4   | 15.2   | 13.3   | 12.0   |   |
|           |       | P <sub>t</sub> |       |        |        | 22.1   | 13.0   | 7.5    | 4.5    | 3.0    |   |
|           |       | NR             |       |        |        | 40     | 34     | 28     | 23     | 18     |   |

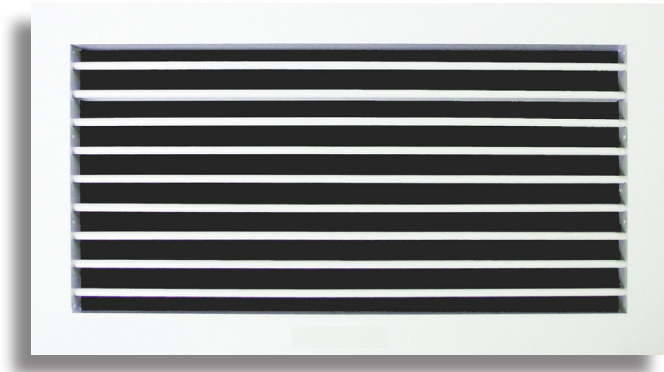

# Single Deflection Grille

### General Information:

For supply air, having a single set of fully adjustable blades to give directional control of the air pattern in two directions if required. Suitable for wall or duct mounting. Also available with curved face for circular duct installations.

From extruded aluminium sections, ensuring functional strength and performance that also gives an attractive and aesthetically pleasing appearance. Incorporating a single set of individually adjustable blades, the blades may be set either horizontally or at angles, either up or down. Powder coated white as standard with optional colors and finishes available on request.

### Features:

- Made of high quality extruded aluminium profile
- Blades are movable on horizontal or vertical lines
- Mounting by screws or spring clips
- Powder coated white as standard

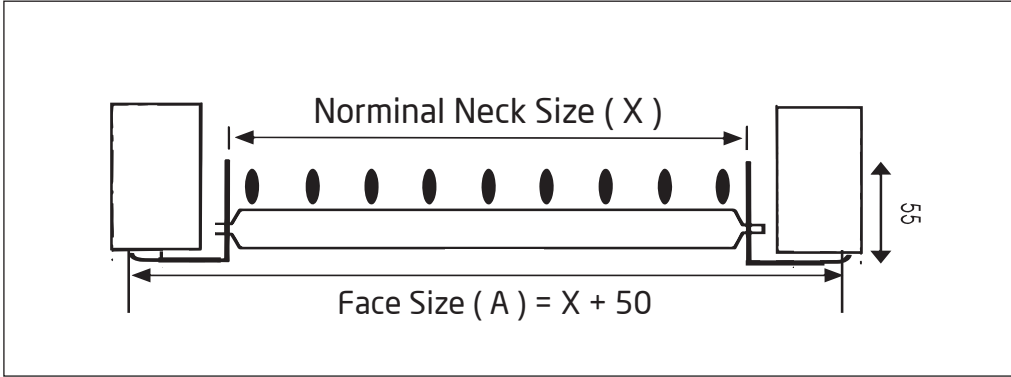

## General notes on the quick selection table:

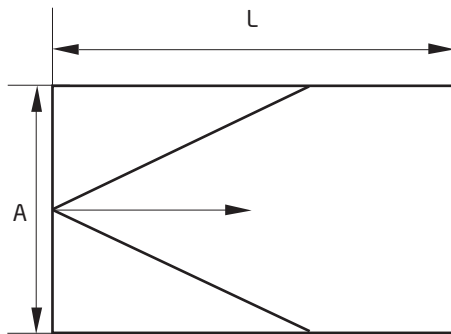

Fig 1

Some correction factors exist as a function of the ratio between room width and length, the blade deflection angle and the distance from grille to ceiling, and are defined in the following manner:

**A/L:** Ratio between the width and the length of the room to be conditioned. For example, for a room with a width of 4.5m and length of 4.5m the factor A/L equals 1 (see fig 1).

**C<sub>a</sub>:** Factor obtained from the graph. For example, if the value of A/L = 1 and for a grille with 0° blade angle, the value of C<sub>a</sub> equals 1.3 (see fig 2).

**C<sub>h</sub>:** Correction factor for height, obtained from the distance between grille and ceiling.

For a free jet C<sub>h</sub> is always 1.1.

For example, if the grille is located at 0.2m from the ceiling the factor C<sub>h</sub> equals 1 (see fig 3&4).

Once calculated, the correction factor for the throw (K<sub>c</sub>) can be determined by the following formula:

$$K_c = C_a * C_h$$

$$K_c = 1.3 * 1$$

In this case of selection by table, we would obtain the correction throw (X<sub>c</sub>):

$$X_c = K_c * X$$

$$X_c = 1.3 * X$$

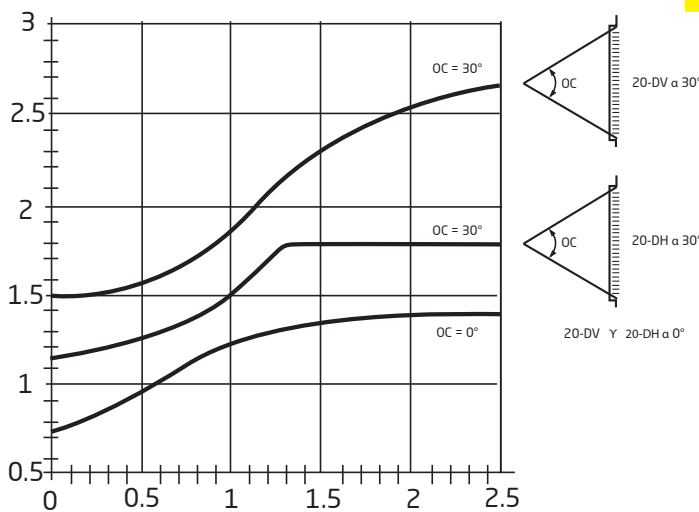

Fig 2

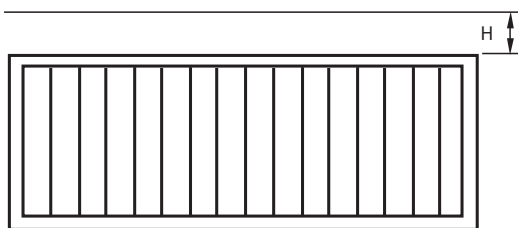

Fig 3

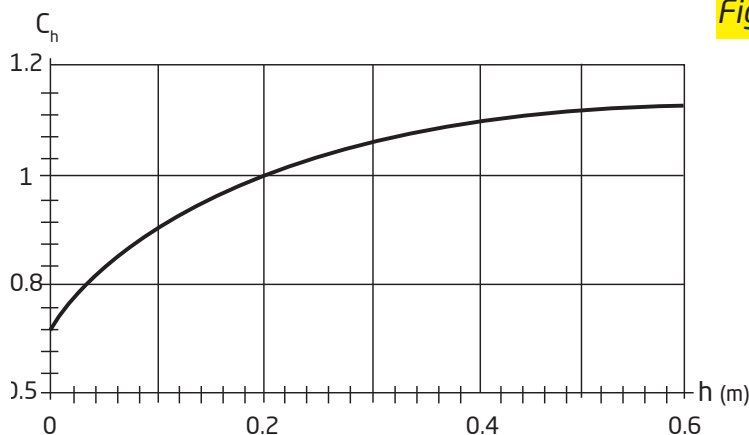

Fig 4

## Quick Selection Table

Symbols:

A<sub>k</sub> - Effective area

V<sub>k</sub> - Effective velocity in m/s

X - Throw in metres correspond to a terminal velocity in occupied zone of 0.25m/s

Pressure (P<sub>t</sub>) - All pressures are in Pa (N/m<sup>2</sup>)

NR - Noise level index in dB based on a room absorption and one diffuser

## Quick Selection Table

| Flow rate           |       | Dim            | 200 x 100      |         | 250 x 100 |         | 300 x 100<br>200 x 150 |        | 250 x 150 |        | 300 x 150 |        | 350 x 150<br>250 x 200 |        | 600 x 100<br>400 x 150<br>300 x 200 |        | 500 x 150<br>350 x 200 |        | 600 x 150<br>450 x 200<br>350 x 250<br>300 x 300 |        | 600 x 200<br>500 x 250<br>400 x 300 |        | 1000 x 150<br>750 x 200<br>600 x 250<br>500 x 300 |        | 1200 x 150<br>900 x 200<br>750 x 250<br>600 x 300 |        | 1100 x 200<br>900 x 250<br>750 x 300 |        | 1200 x 250<br>1000 x 300 |        |  |  |  |  |  |  |  |
|---------------------|-------|----------------|----------------|---------|-----------|---------|------------------------|--------|-----------|--------|-----------|--------|------------------------|--------|-------------------------------------|--------|------------------------|--------|--|--------|-------------------------------------|--------|---|--------|---|--------|--------------------------------------|--------|--------------------------|--------|--|--|--|--|--|--|--|
|                     |       |                | A <sub>k</sub> | 0.00098 |           | 0.00125 |                        | 0.0148 |           | 0.0183 |           | 0.0224 |                        | 0.0262 |                                     | 0.0309 |                        | 0.0381 |  | 0.0474 |                                     | 0.0660 |   | 0.0801 |   | 0.0970 |                                      | 0.1210 |                          | 0.1670 |  |  |  |  |  |  |  |
| (m <sup>3</sup> /h) | (l/s) | Ø              | 0°             | 30°     | 0°        | 30°     | 0°                     | 30°    | 0°        | 30°    | 0°        | 30°    | 0°                     | 30°    | 0°                                  | 30°    | 0°                     | 30°    | 0°   | 30°    | 0°                                  | 30°    | 0°  | 30°    | 0°  | 30°    | 0°                                   | 30°    | 0°                       | 30°    |  |  |  |  |  |  |  |
| 100                 | 27.8  | V <sub>k</sub> | 2.24           | 2.24    | 1.76      | 1.76    | 1.52                   | 1.52   | 1.2       | 1.2    | 0.96      | 0.96   | 0.88                   | 0.88   | 0.72                                | 0.72   | 0.56                   | 0.56   | 0.48   | 0.48   |                                     |        |   |        |   |        |                                      |        |                          |        |  |  |  |  |  |  |  |
|                     |       | X              | 2.42           | 1.98    | 2.09      | 1.76    | 1.98                   | 1.54   | 1.76      | 1.43   | 1.65      | 1.32   | 1.43                   | 1.21   | 1.32                                | 1.1    | 1.21                   | 0.99   | 1.1  | 0.88   |                                     |        |   |        |   |        |                                      |        |                          |        |  |  |  |  |  |  |  |
|                     |       | P <sub>t</sub> | 2.56           | 3.12    | 1.6       | 1.92    | 1.12                   | 1.36   | 0.72      | 0.88   | 0.48      | 0.56   | 0.32                   | 0.4    | 0.24                                | 0.32   | 0.16                   | 0.24   | 0.08   | 0.16   |                                     |        |   |        |   |        |                                      |        |                          |        |  |  |  |  |  |  |  |
|                     |       | NR             | 9              | 10.8    | 4.5       | 6.3     | -                      | -      | -         | -      | -         | -      | -                      | -      | -                                   | -      | -                      | -      | -  | -      | -                                   |        |   |        |   |        |                                      |        |                          |        |  |  |  |  |  |  |  |
| 150                 | 41.7  | V <sub>k</sub> | 3.44           | 3.44    | 2.64      | 2.64    | 2.24                   | 2.24   | 1.84      | 1.84   | 1.52      | 1.52   | 1.28                   | 1.28   | 1.04                                | 1.04   | 0.88                   | 0.88   | 0.72   | 0.72   | 0.48                                | 0.48   |   |        |   |        |                                      |        |                          |        |  |  |  |  |  |  |  |
|                     |       | X              | 3.63           | 2.86    | 3.19      | 2.53    | 2.97                   | 2.31   | 2.64      | 2.09   | 2.42      | 1.87   | 2.2                    | 1.76   | 2.09                                | 1.65   | 1.87                   | 1.43   | 1.65   | 1.32   | 1.43                                | 1.1    |   |        |   |        |                                      |        |                          |        |  |  |  |  |  |  |  |
|                     |       | P <sub>t</sub> | 5.76           | 6.96    | 3.52      | 4.24    | 2.56                   | 3.04   | 1.68      | 2      | 1.12      | 1.36   | 0.8                    | 0.96   | 0.56                                | 0.72   | 0.4                    | 0.48   | 0.24   | 0.32   | 0.16                                | 0.16   |   |        |   |        |                                      |        |                          |        |  |  |  |  |  |  |  |
|                     |       | NR             | 18             | 19.8    | 13.5      | 15.3    | 10.8                   | 12.6   | 7.2       | 9      | 3.6       | 5.4    | -                      | -      | -                                   | -      | -                      | -      | -  | -      | -                                   | -      |   |        |   |        |                                      |        |                          |        |  |  |  |  |  |  |  |
| 200                 | 55.6  | V <sub>k</sub> | 4.56           | 4.56    | 3.52      | 3.52    | 3.04                   | 3.04   | 2.4       | 2.4    | 2         | 2      | 1.68                   | 1.68   | 1.44                                | 1.44   | 1.2                    | 1.2    | 0.96   | 0.96   | 0.64                                | 0.64   | 0.56  | 0.56   |   |        |                                      |        |                          |        |  |  |  |  |  |  |  |
|                     |       | X              | 4.84           | 3.85    | 4.29      | 3.41    | 3.96                   | 3.19   | 3.52      | 2.86   | 3.19      | 2.53   | 2.97                   | 2.42   | 2.75                                | 2.2    | 2.42                   | 1.98   | 2.2  | 1.76   | 1.87                                | 1.54   | 1.65  | 1.32   |   |        |                                      |        |                          |        |  |  |  |  |  |  |  |
|                     |       | P <sub>t</sub> | 10.3           | 12.3    | 6.32      | 7.6     | 4.48                   | 5.44   | 2.96      | 3.52   | 2         | 2.4    | 1.44                   | 1.76   | 1.04                                | 1.28   | 0.72                   | 0.8    | 0.4  | 0.56   | 0.24                                | 0.24   | 0.16  | 0.16   |   |        |                                      |        |                          |        |  |  |  |  |  |  |  |
|                     |       | NR             | 24.3           | 26.1    | 19.8      | 21.6    | 17.1                   | 18.9   | 13.5      | 15.3   | 9.9       | 11.7   | 7.2                    | 9      | 4.5                                 | 6.3    | -                      | -      | -  | -      | -                                   | -      | -   | -      | -   |        |                                      |        |                          |        |  |  |  |  |  |  |  |
| 250                 | 69.4  | V <sub>k</sub> | 5.68           | 5.68    | 4.48      | 4.48    | 3.76                   | 3.76   | 3.04      | 3.04   | 2.48      | 2.48   | 2.16                   | 2.16   | 1.76                                | 1.76   | 1.44                   | 1.44   | 1.2  | 1.2    | 0.88                                | 0.88   | 0.72  | 0.72   |   |        |                                      |        |                          |        |  |  |  |  |  |  |  |
|                     |       | X              | 6.05           | 4.84    | 5.39      | 4.29    | 4.95                   | 3.96   | 4.4       | 3.52   | 3.96      | 3.19   | 5.83                   | 2.97   | 3.41                                | 2.75   | 3.08                   | 2.42   | 2.75   | 2.2    | 2.31                                | 1.87   | 2.09  | 1.65   |   |        |                                      |        |                          |        |  |  |  |  |  |  |  |
|                     |       | P <sub>t</sub> | 16             | 19.2    | 9.84      | 11.8    | 7.04                   | 8.48   | 4.64      | 5.52   | 3.04      | 3.68   | 2.24                   | 2.72   | 1.6                                 | 1.92   | 1.04                   | 1.28   | 0.72   | 0.8    | 0.32                                | 0.4    | 0.24  | 0.32   |   |        |                                      |        |                          |        |  |  |  |  |  |  |  |
|                     |       | NR             | 29.7           | 31.5    | 25.2      | 27      | 21.6                   | 23.4   | 18        | 19.8   | 14.4      | 16.2   | 11.7                   | 13.5   | 9                                   | 10.8   | 5.4                    | 7.2    | -  | -      | -                                   | -      | -   | -      | -   |        |                                      |        |                          |        |  |  |  |  |  |  |  |
| 300                 | 83.3  | V <sub>k</sub> | 6.8            | 6.8     | 5.36      | 5.36    | 4.48                   | 4.48   | 3.68      | 3.68   | 2.96      | 2.96   | 2.56                   | 2.56   | 2.16                                | 2.16   | 1.76                   | 1.76   | 1.44   | 1.44   | 1.04                                | 1.04   | 0.8   | 0.8    | 0.72  | 0.72   |                                      |        |                          |        |  |  |  |  |  |  |  |
|                     |       | X              | 7.26           | 5.83    | 6.38      | 5.17    | 5.94                   | 4.73   | 5.28      | 4.29   | 4.84      | 3.85   | 4.4                    | 3.52   | 4.07                                | 3.3    | 3.63                   | 2.97   | 3.3  | 2.64   | 2.75                                | 2.2    | 2.53  | 1.98   | 2.31  | 1.87   |                                      |        |                          |        |  |  |  |  |  |  |  |
|                     |       | P <sub>t</sub> | 23.1           | 27.7    | 14.2      | 16.64   | 8                      | 4.4    | 5.28      | 3.2    | 3.92      | 2.32   | 2.8                    | 1.52   | 1.84                                | 0.96   | 1.2                    | 0.48   | 0.64   | 0.32   | 0.4                                 | 0.24   | 0.32  | 0.5    | 0.3   | 0.4    |                                      |        |                          |        |  |  |  |  |  |  |  |
|                     |       | NR             | 33.3           | 35.1    | 28.8      | 30.6    | 26.1                   | 27.9   | 22.5      | 24.3   | 18.9      | 20.7   | 16.2                   | 18     | 13.5                                | 15.3   | 9                      | 10.8   | 5.4  | 7.2    | -                                   | -      | -   | -      | -   | -      |                                      |        |                          |        |  |  |  |  |  |  |  |
| 350                 | 97.2  | V <sub>k</sub> | 7.92           | 7.92    | 6.24      | 6.24    | 5.28                   | 5.28   | 4.24      | 4.24   | 3.44      | 3.44   | 2.96                   | 2.96   | 2.48                                | 2.48   | 2.08                   | 2.08   | 1.68   | 1.68   | 1.2                                 | 1.2    | 0.96  | 0.96   | 0.8   | 0.8    |                                      |        |                          |        |  |  |  |  |  |  |  |
|                     |       | X              | 8.47           | 6.82    | 7.48      | 6.05    | 6.93                   | 5.5    | 6.16      | 4.95   | 5.61      | 4.51   | 5.17                   | 4.18   | 4.73                                | 3.85   | 4.29                   | 3.41   | 3.85   | 3.08   | 3.3                                 | 2.64   | 2.97  | 2.42   | 2.64  | 2.2    |                                      |        |                          |        |  |  |  |  |  |  |  |
|                     |       | P <sub>t</sub> | 31.5           | 37.7    | 19.3      | 23.2    | 13.8                   | 16.5   | 9.04      | 10.8   | 6         | 7.2    | 4.4                    | 5.28   | 3.2                                 | 3.84   | 2.08                   | 2.48   | 1.36   | 1.6    | 0.72                                | 0.8    | 0.48  | 0.56   | 0.32  | 0.4    |                                      |        |                          |        |  |  |  |  |  |  |  |
|                     |       | NR             | 36.9           | 38.7    | 32.4      | 34.2    | 29.7                   | 31.5   | 26.1      | 27.9   | 22.5      | 24.3   | 18.9                   | 20.7   | 16.2                                | 18     | 12.6                   | 14.4   | 9  | 10.8   | -                                   | -      | -   | -      | -   | -      |                                      |        |                          |        |  |  |  |  |  |  |  |
| 400                 | 111.1 | V <sub>k</sub> | 9.04           | 9.04    | 7.12      | 7.12    | 6                      | 6      | 4.88      | 4.88   | 4         | 4      | 3.36                   | 3.36   | 2.88                                | 2.88   | 2.32                   | 2.32   | 1.84   | 1.84   | 1.36                                | 1.36   | 1.12  | 1.12   | 0.88  | 0.88   | 0.72                                 | 0.72   |                          |        |  |  |  |  |  |  |  |
|                     |       | X              | 9.68           | 7.7     | 8.58      | 6.82    | 7.92                   | 6.27   | 7.04      | 5.61   | 6.38      | 5.17   | 5.94                   | 4.73   | 5.5                                 | 4.4    | 4.95                   | 3.96   | 4.4  | 3.52   | 3.74                                | 2.97   | 3.41  | 2.75   | 3.08  | 2.42   | 2.75                                 | 2.2    |                          |        |  |  |  |  |  |  |  |
|                     |       | P <sub>t</sub> | 41.1           | 49.3    | 25.2      | 30.2    | 18                     | 21.6   | 11.7      | 13.8   | 8.4       | 9.44   | 5.76                   | 6.88   | 4.16                                | 4.96   | 2.72                   | 3.28   | 1.76   | 2.08   | 0.88                                | 1.12   | 0.64  | 0.72   | 0.4   | 0.48   | 0.24                                 | 0.32   |                          |        |  |  |  |  |  |  |  |
|                     |       | NR             | 39.6           | 41.4    | 35.1      | 36.9    | 32.4                   | 34.2   | 28.8      | 30.6   | 25.2      | 27     | 22.5                   | 24.3   | 19.8                                | 21.6   | 15.3                   | 17.1   | 11.7   | 13.5   | 6.3                                 | 8.1    | -   | -      | -   | -      | -                                    | -      |                          |        |  |  |  |  |  |  |  |
| 450                 | 125.0 | V <sub>k</sub> |                |         | 8         | 8       | 6.72                   | 6.72   | 5.44      | 5.44   | 4.48      | 4.48   | 3.84                   | 3.84   | 3.2                                 | 3.2    | 2.64                   | 2.64   | 2.08   | 2.08   | 1.52                                | 1.52   | 1.28  | 1.28   | 1.04  | 1.04   | 0.8                                  | 0.8    |                          |        |  |  |  |  |  |  |  |
|                     |       | X              |                |         | 9.68      | 7.7     | 8.91                   | 7.04   | 7.92      | 6.38   | 7.15      | 5.72   | 6.71                   | 5.28   | 6.16                                | 4.95   | 5.5                    | 4.4    | 4.95   | 3.96   | 4.18                                | 3.41   | 3.85  | 3.08   | 3.41  | 2.75   | 3.08                                 | 2.42   | 2.75                     | 2.2    |  |  |  |  |  |  |  |
|                     |       | P <sub>t</sub> |                |         | 32        | 38.4    | 22.8                   | 27.3   | 14.9      | 17.9   | 10        | 11.9   | 7.28                   | 8.72   | 5.2                                 | 6.32   | 3.44                   | 4.16   | 2.24   | 2.64   | 1.12                                | 1.36   | 0.8   | 0.96   | 0.56  | 0.64   | 0.32                                 | 0.4    |                          |        |  |  |  |  |  |  |  |
|                     |       | NR             |                |         | 37.8      | 39.6    | 35.1                   | 36.9   | 31.5      | 33.3   | 27.9      | 29.7   | 25.2                   | 27     | 21.6                                | 23.4   | 18                     | 19.8   | 14.4   | 16.2   | 9                                   | 10.8   | 5.4   | 7.2    | -   | -      | -                                    | -      |                          |        |  |  |  |  |  |  |  |
| 500                 | 138.9 | V <sub>k</sub> |                |         | 8.88      | 8.88    | 7.52                   | 7.52   | 6.08      | 6.08   | 4.96      | 4.96   | 4.24                   | 4.24   | 3.6                                 | 3.6    | 2.88                   | 2.88   | 2.32   | 2.32   | 1.68                                | 1.68   | 1.36  | 1.36   | 1.12  | 1.12   | 0.88                                 | 0.88   | 0.64                     | 0.64   |  |  |  |  |  |  |  |
|                     |       | X              |                |         | 10.6      | 8.58    | 9.79                   | 7.92   | 8.8       | 7.04   | 8.03      | 6.38   | 7.37                   | 5.94   | 6.82                                | 5.5    | 6.16                   | 4.95   | 5.5  | 4.4    | 4.62                                | 3.74   | 4.18  | 3.41   | 3.85  | 3.08   | 3.41                                 | 2.75   | 2.97                     | 2.31   |  |  |  |  |  |  |  |
|                     |       | P <sub>t</sub> |                |         | 39.5      | 47.4    | 28.1                   | 33.8   | 18.4      | 22     | 12.3      | 14.8   | 8.96                   | 10.8   | 6.48                                | 7.76   | 4.24                   | 5.12   | 2.72   | 3.28   | 1.44                                | 1.68   | 0.96  | 1.12   | 0.64  | 0.8    | 0.4                                  | 0.48   | 0.24                     | 0.24   |  |  |  |  |  |  |  |
|                     |       | NR             |                |         |           |         | 36.9                   | 38.7   | 33.3      | 35.1   | 29.7      | 31.5   | 27                     | 28.8   | 24.3                                | 26.1   | 20.7                   | 22.5   | 17.1   | 18.9   | 10.8                                | 12.6   | 7.2   | 9      | 4.5   | 6.3    | -                                    | -      | -                        | -      |  |  |  |  |  |  |  |
| 550                 | 152.8 | V <sub>k</sub> |                |         |           |         | 8.24                   | 8.24   | 6.64      | 6.64   | 5.44      | 5.44   | 4.64                   | 4.64   | 3.92                                | 3.92   | 3.2                    | 3.2    | 2.56   | 2.56   | 1.84                                | 1.84   | 1.52  | 1.52   | 1.28  | 1.28   | 1.04                                 | 1.04   | 0.72                     | 0.72   |  |  |  |  |  |  |  |
|                     |       | X              |                |         |           |         | 10.7                   | 8.69   | 9.79      | 7.81   | 8.8       | 7.04   | 8.14                   | 6.49   | 7.48                                | 5.94   | 6.71                   | 5.39   | 6.05   | 4.84   | 5.17                                | 4.07   | 4.62  | 3.74   | 4.18  | 3.41   | 3.74                                 | 3.08   | 3.19                     | 2.53   |  |  |  |  |  |  |  |
|                     |       | P <sub>t</sub> |                |         |           |         | 34                     | 40.8   | 22.3      | 26.8   | 14.8      | 17.8   | 10.8                   | 13     | 7.84                                | 9.36   | 5.12                   | 6.16   |  |        |                                     |        |   |        |   |        |                                      |        |                          |        |  |  |  |  |  |  |  |

Quick Selection Table

| Flow rate           |       | Dim            | 200 x 100      |         | 250 x 100 |         | 300 x 100<br>200 x 150 |        | 250 x 150 |        | 300 x 150 |        | 350 x 150<br>250 x 200 |        | 600 x 100<br>400 x 150<br>300 x 200 |        | 500 x 150<br>350 x 200 |        | 600 x 150<br>450 x 200<br>350 x 250<br>300 x 300 |        | 600 x 200<br>500 x 250<br>400 x 300 |        | 1000 x 150<br>750 x 200<br>600 x 250<br>500 x 300 |        | 1200 x 150<br>900 x 200<br>750 x 250<br>600 x 300 |        | 1100 x 200<br>900 x 250<br>750 x 300 |        | 1200 x 250<br>1000 x 300 |        |      |      |      |
|---------------------|-------|----------------|----------------|---------|-----------|---------|------------------------|--------|-----------|--------|-----------|--------|------------------------|--------|-------------------------------------|--------|------------------------|--------|--|--------|-------------------------------------|--------|---|--------|---|--------|--------------------------------------|--------|--------------------------|--------|------|------|------|
|                     |       |                | A <sub>k</sub> | 0.00098 |           | 0.00125 |                        | 0.0148 |           | 0.0183 |           | 0.0224 |                        | 0.0262 |                                     | 0.0309 |                        | 0.0381 |  | 0.0474 |                                     | 0.0660 |   | 0.0801 |   | 0.0970 |                                      | 0.1210 |                          | 0.1670 |      |      |      |
| (m <sup>3</sup> /h) | (l/s) | Ø              | 0°             | 30°     | 0°        | 30°     | 0°                     | 30°    | 0°        | 30°    | 0°        | 30°    | 0°                     | 30°    | 0°                                  | 30°    | 0°                     | 30°    | 0°   | 30°    | 0°                                  | 30°    | 0°  | 30°    | 0°  | 30°    | 0°                                   | 30°    | 0°                       | 30°    |      |      |      |
| 600                 | 166.7 | V <sub>k</sub> |                |         |           |         | 9.04                   | 9.04   | 7.28      | 7.28   | 6.72      | 5.92   | 5.12                   | 5.12   | 4.32                                | 4.32   | 3.52                   | 3.52   | 2.8  | 2.8    | 2                                   | 2      | 1.68  | 1.68   | 1.36  | 1.36   | 1.12                                 | 1.12   | 0.8                      | 0.8    |      |      |      |
|                     |       | X              |                |         |           |         | 11.7                   | 9.46   | 10.6      | 8.47   | 9.57      | 7.7    | 8.91                   | 7.15   | 8.14                                | 6.49   | 7.37                   | 5.94   | 6.6  | 5.28   | 5.61                                | 4.51   | 5.06  | 4.07   | 4.62  | 3.74   | 4.18                                 | 3.3    | 3.52                     | 2.86   |      |      |      |
|                     |       | P <sub>t</sub> |                |         |           |         | 40.5                   | 48.7   | 26.5      | 31.8   | 17.6      | 21.2   | 12.9                   | 15.5   | 9.28                                | 11.2   | 6.16                   | 7.36   | 3.92   | 4.72   | 2.08                                | 2.48   | 1.36  | 1.68   | 0.96  | 1.12   | 0.64                                 | 0.72   | 0.32                     | 0.4    |      |      |      |
|                     |       | NR             |                |         |           |         | 41.4                   | 43.2   | 37.8      | 39.6   | 34.2      | 36     | 31.5                   | 33.3   | 27.9                                | 29.7   | 24.3                   | 26.1   | 20.7   | 22.5   | 15.3                                | 17.1   | 11.7  | 13.5   | 8.1   | 9.9    | 4.5                                  | 6.3    | -                        | -      |      |      |      |
| 650                 | 180.6 | V <sub>k</sub> |                |         |           |         | 9.76                   | 9.76   | 7.92      | 7.92   | 6.48      | 6.48   | 5.52                   | 5.52   | 4.64                                | 4.64   | 3.76                   | 3.76   | 3.04   | 3.04   | 2.16                                | 2.16   | 1.84  | 1.84   | 2.32  | 1.52   | 1.2                                  | 1.2    | 0.88                     | 0.88   |      |      |      |
|                     |       | X              |                |         |           |         | 12.7                   | 10.2   | 11.5      | 9.24   | 10.4      | 8.36   | 9.57                   | 7.7    | 8.8                                 | 7.04   | 7.92                   | 6.38   | 7.15   | 5.72   | 6.05                                | 4.84   | 5.5   | 4.4    | 4.95  | 3.96   | 4.51                                 | 3.63   | 3.85                     | 3.08   |      |      |      |
|                     |       | P <sub>t</sub> |                |         |           |         | 47.6                   | 57.1   | 31.1      | 37.3   | 20.8      | 24.9   | 15.2                   | 18.2   | 10.9                                | 13.1   | 7.2                    | 8.64   | 4.64   | 5.6    | 2.4                                 | 2.88   | 1.6   | 1.92   | 1.12  | 1.36   | 0.72                                 | 0.88   | 0.4                      | 0.48   |      |      |      |
|                     |       | NR             |                |         |           |         | 43.2                   | 45     | 39.6      | 41.4   | 36        | 37.8   | 33.3                   | 35.1   | 29.7                                | 31.5   | 26.1                   | 27.9   | 22.5   | 24.3   | 16.2                                | 18     | 13.5  | 15.3   | 9.9   | 11.7   | 6.3                                  | 8.1    | -                        | -      |      |      |      |
| 700                 | 194.4 | V <sub>k</sub> |                |         |           |         |                        |        | 8.48      | 8.48   | 6.96      | 6.96   | 5.92                   | 5.92   | 5.04                                | 5.04   | 4.08                   | 4.08   | 3.28   | 3.28   | 2.32                                | 2.32   | 1.92  | 1.92   | 1.6   | 1.6    | 1.28                                 | 1.28   | 0.96                     | 0.96   |      |      |      |
|                     |       | X              |                |         |           |         |                        |        | 12.4      | 9.9    | 11.2      | 8.91   | 10.3                   | 8.25   | 9.57                                | 7.59   | 8.58                   | 6.82   | 7.7  | 6.16   | 6.49                                | 5.17   | 5.94  | 4.73   | 5.39  | 4.29   | 4.84                                 | 3.85   | 4.07                     | 3.3    |      |      |      |
|                     |       | P <sub>t</sub> |                |         |           |         |                        |        | 36.1      | 43.3   | 24        | 28.9   | 17.6                   | 21.1   | 12.6                                | 15.2   | 8.32                   | 10     | 5.36   | 6.48   | 2.8                                 | 3.36   | 1.92  | 2.24   | 1.28  | 1.52   | 0.8                                  | 0.96   | 0.4                      | 0.56   |      |      |      |
|                     |       | NR             |                |         |           |         |                        |        | 40.5      | 42.3   | 36.9      | 38.7   | 34.2                   | 36     | 31.5                                | 33.3   | 27.9                   | 29.7   | 24.3   | 26.1   | 18                                  | 19.8   | 15.3  | 17.1   | 11.7  | 13.5   | 7.2                                  | 9      | -                        | -      |      |      |      |
| 750                 | 208.3 | V <sub>k</sub> |                |         |           |         |                        |        | 9.12      | 9.12   | 7.44      | 7.44   | 6.4                    | 6.4    | 5.36                                | 5.36   | 4.4                    | 4.4    | 3.52   | 3.52   | 2.56                                | 2.56   | 2.08  | 2.08   | 1.68  | 1.68   | 1.36                                 | 1.36   | 0.96                     | 0.96   |      |      |      |
|                     |       | X              |                |         |           |         |                        |        | 13.1      | 10.6   | 11.9      | 9.57   | 11.1                   | 8.91   | 10.2                                | 8.14   | 9.24                   | 7.37   | 8.25   | 6.6    | 7.04                                | 5.61   | 6.38  | 5.06   | 5.72  | 4.62   | 5.17                                 | 4.18   | 4.4                      | 3.52   |      |      |      |
|                     |       | P <sub>t</sub> |                |         |           |         |                        |        | 41.4      | 49.7   | 27.6      | 33.2   | 20.2                   | 24.2   | 14.5                                | 17.4   | 9.6                    | 11.5   | 6.16   | 7.44   | 3.2                                 | 3.84   | 2.16  | 2.56   | 1.44  | 1.76   | 0.96                                 | 1.12   | 0.48                     | 0.56   |      |      |      |
|                     |       | NR             |                |         |           |         |                        |        | 42.3      | 44.1   | 38.7      | 40.5   | 36                     | 37.8   | 33.3                                | 35.1   | 29.7                   | 31.5   | 25.2   | 27     | 19.8                                | 21.6   | 16.2  | 18     | 12.6  | 14.4   | 9                                    | 10.8   | -                        | -      |      |      |      |
| 800                 | 222.2 | V <sub>k</sub> |                |         |           |         |                        |        | 9.68      | 9.68   | 7.92      | 7.92   | 6.8                    | 6.8    | 5.76                                | 5.76   | 4.64                   | 4.64   | 3.76   | 3.76   | 2.72                                | 2.72   | 2.24  | 2.24   | 1.84  | 1.84   | 1.44                                 | 1.44   | 1.04                     | 1.04   |      |      |      |
|                     |       | X              |                |         |           |         |                        |        | 12.9      | 10.3   | 11.6      | 9.3    | 10.8                   | 8.6    | 9.9                                 | 7.9    | 8.9                    | 7.1    | 8  | 6.4    | 6.8                                 | 5.4    | 6.2   | 4.9    | 5.6   | 4.5    | 5                                    | 4      | 4.3                      | 3.4    |      |      |      |
|                     |       | P <sub>t</sub> |                |         |           |         |                        |        | 14.1      | 11.3   | 12.7      | 10.2   | 11.8                   | 9.46   | 10.8                                | 8.69   | 9.79                   | 7.81   | 8.8  | 7.04   | 7.48                                | 5.94   | 6.82  | 5.39   | 6.16  | 4.95   | 5.5                                  | 4.4    | 4.73                     | 3.74   |      |      |      |
|                     |       | NR             |                |         |           |         |                        |        | 44.1      | 45.9   | 40.5      | 42.3   | 37.8                   | 39.6   | 34.2                                | 36     | 30.6                   | 32.4   | 27   | 28.8   | 21.6                                | 23.4   | 18  | 19.8   | 14.4  | 16.2   | 10.8                                 | 12.6   | -                        | -      |      |      |      |
| 850                 | 236.1 | V <sub>k</sub> |                |         |           |         |                        |        |           |        |           |        | 8.4                    | 8.4    | 7.2                                 | 7.2    | 6.08                   | 6.08   | 4.96   | 4.96   | 4                                   | 4      | 2.88  | 2.88   | 2.32  | 2.32   | 1.92                                 | 1.92   | 1.6                      | 1.6    | 1.12 | 1.12 |      |
|                     |       | X              |                |         |           |         |                        |        |           |        |           |        |                        | 13.6   | 10.8                                | 12.5   | 10                     | 11.5   | 9.24   | 10.4   | 8.36                                | 9.35   | 7.48  | 7.92   | 6.38  | 7.15   | 5.72                                 | 6.49   | 5.28                     | 5.83   | 4.73 | 4.95 | 3.96 |
|                     |       | P <sub>t</sub> |                |         |           |         |                        |        |           |        |           |        |                        | 35.5   | 42.6                                | 26     | 31.2                   | 18.7   | 22.4   | 12.3   | 14.7                                | 7.92   | 9.52  | 4.08   | 4.88  | 2.8    | 3.36                                 | 1.92   | 2.24                     | 1.2    | 1.44 | 0.64 | 0.8  |
|                     |       | NR             |                |         |           |         |                        |        |           |        |           |        |                        | 41.4   | 43.2                                | 38.7   | 40.5                   | 36     | 37.8   | 32.4   | 34.2                                | 27.9   | 29.7  | 22.5   | 24.3  | 18.9   | 20.7                                 | 15.3   | 17.1                     | 11.7   | 13.5 | 6.3  | 8.1  |
| 900                 | 250.0 | V <sub>k</sub> |                |         |           |         |                        |        |           |        |           |        | 8.96                   | 8.96   | 7.6                                 | 7.6    | 6.48                   | 6.48   | 5.28   | 5.28   | 4.24                                | 4.24   | 3.04  | 3.04   | 2.48  | 2.48   | 2.08                                 | 2.08   | 1.68                     | 1.68   | 1.2  | 1.2  |      |
|                     |       | X              |                |         |           |         |                        |        |           |        |           |        |                        | 14.4   | 11.5                                | 13.3   | 10.6                   | 12.2   | 9.79   | 11     | 8.8                                 | 9.9    | 7.92  | 8.36   | 6.71  | 7.59   | 6.05                                 | 6.93   | 5.5                      | 6.16   | 4.95 | 5.28 | 4.18 |
|                     |       | P <sub>t</sub> |                |         |           |         |                        |        |           |        |           |        |                        | 39.8   | 47.8                                | 29.1   | 34.9                   | 20.9   | 25.1   | 13.7   | 16.5                                | 8.88   | 10.7  | 4.56   | 5.52  | 3.12   | 3.76                                 | 2.16   | 2.56                     | 1.36   | 1.6  | 0.72 | 0.88 |
|                     |       | NR             |                |         |           |         |                        |        |           |        |           |        |                        | 43.2   | 45                                  | 39.6   | 41.4                   | 36.9   | 38.7   | 33.3   | 35.1                                | 29.7   | 31.5  | 23.4   | 25.2  | 20.7   | 22.5                                 | 17.1   | 18.9                     | 13.5   | 15.3 | 7.2  | 9    |
| 950                 | 263.9 | V <sub>k</sub> |                |         |           |         |                        |        |           |        |           |        |                        | 9.44   | 9.44                                | 8.08   | 8.08                   | 6.8    | 6.8  | 5.52   | 5.52                                | 4.48   | 4.48  | 3.2    | 3.2   | 2.64   | 2.64                                 | 2.16   | 2.16                     | 1.76   | 1.76 | 1.28 | 1.28 |
|                     |       | X              |                |         |           |         |                        |        |           |        |           |        |                        | 15.2   | 12.2                                | 14.1   | 11.2                   | 13.0   | 10.3   | 11.7   | 9.4                                 | 10.5   | 8.4   | 8.8    | 7.0   | 8.0    | 6.4                                  | 7.3    | 5.8                      | 6.5    | 5.3  | 5.6  | 4.4  |
|                     |       | P <sub>t</sub> |                |         |           |         |                        |        |           |        |           |        |                        | 44.4   | 53.3                                | 32.5   | 39.0                   | 23.4   | 28.0   | 15.4   | 18.4                                | 9.9    | 11.9  | 5.1    | 6.2   | 3.4    | 4.2                                  | 2.4    | 2.9                      | 1.5    | 1.8  | 0.8  | 1.0  |
|                     |       | NR             |                |         |           |         |                        |        |           |        |           |        |                        | 44.1   | 45.9                                | 41.4   | 43.2                   | 38.7   | 40.5   | 34.2   | 36.0                                | 30.6   | 32.4  | 25.2   | 27.0  | 21.6   | 23.4                                 | 18.0   | 19.8                     | 14.4   | 16.2 | 9.0  | 10.8 |
| 1000                | 277.8 | V <sub>k</sub> |                |         |           |         |                        |        |           |        |           |        |                        | 8.5    | 8.5                                 | 7.2    | 7.2                    | 5.8    | 5.8  | 4.7    | 4.7                                 | 3.4    | 3.4   | 2.8    | 2.8   | 2.3    | 2.3                                  | 1.8    | 1.8                      | 1.4    | 1.4  |      |      |
|                     |       | X              |                |         |           |         |                        |        |           |        |           |        |                        | 14.7   | 11.9                                | 13.6   | 10.9                   | 12.3   | 9.8  | 11.0   | 8.8                                 | 9.4    | 7.5   | 8.5    | 6.8   | 7.7    | 6.2                                  | 6.9    | 5.5                      | 5.8    | 4.7  |      |      |
|                     |       | P <sub>t</sub> |                |         |           |         |                        |        |           |        |           |        |                        | 36.0   | 43.2                                | 25.8   | 31.0                   | 17.0   | 20.4   | 11.0   | 13.2                                | 5.7    | 6.8   | 3.8    | 4.6   | 2.6    | 3.1                                  | 1.7    | 2.0                      | 0.9    | 1.0  |      |      |
|                     |       | NR             |                |         |           |         |                        |        |           |        |           |        |                        | 42.3   | 44.1                                | 39.6   | 41.4                   | 36.0   | 37.8   | 31.5   | 33.3                                | 26.1   | 27.9  | 22.5   | 24.3  | 18.9   | 20.7                                 | 15.3   | 17.1                     | 9.9    | 11.7 |      |      |
| 1100                | 305.6 | V <sub>k</sub> |                |         |           |         |                        |        |           |        |           |        |                        | 9.4    | 9.4                                 | 7.9    | 7.9                    | 6.4    | 6.4  | 5.1    | 5.1                                 | 3.7    | 3.7   | 3.0    | 3.0   | 2.6    | 2.6                                  | 2.0    | 2.0                      | 1.4    | 1.4  |      |      |
|                     |       | X              |                |         |           |         |                        |        |           |        |           |        |                        | 16.3   | 13.0                                | 15.0   | 12.0                   | 13.5   | 10.8   | 12.1   | 9.7                                 | 10.2   | 8.3   | 9.4    | 7.5   | 8.5    | 6.8                                  | 7.6    | 6.1                      | 6.5    | 5.2  |      |      |
|                     |       | P <sub>t</sub> |                |         |           |         |                        |        |           |        |           |        |                        | 43.5   | 52.2                                | 31.3   | 37.5                   | 20.6   | 24.7   | 13.3   | 15.9                                | 6.9    | 8.2   | 4.6    | 5.6   | 3.2    | 3.8                                  | 2.1    | 2.5                      | 1.0    | 1.3  |      |      |
|                     |       | NR             |                |         |           |         |                        |        |           |        |           |        |                        | 44.1   | 45.9                                | 41.4   | 43.2                   | 37.8   | 39.6   | 34.2   | 36.0                                | 27.9   | 29.7  | 25.2   | 27.0  | 21.6   | 23.4                                 | 17.1   | 18.9                     | 11.7   | 13.5 |      |      |

**Quick Selection Table**

| Flow rate           |       | Dim            | 200 x 100      |    | 250 x 100 |    | 300 x 100<br>200 x 150 |    | 250 x 150 |    | 300 x 150 |    | 350 x 150<br>250 x 200 |    | 600 x 100<br>400 x 150<br>300 x 200 |      | 500 x 150<br>350 x 200 |      | 600 x 150<br>450 x 200<br>350 x 250<br>300 x 300 |      | 600 x 200<br>500 x 250<br>400 x 300 |      | 1000 x 150<br>750 x 200<br>600 x 250<br>500 x 300 |      | 1200 x 150<br>900 x 200<br>750 x 250<br>600 x 300 |      | 1100 x 200<br>900 x 250<br>750 x 300 |      | 1200 x 250<br>1000 x 300 |      |     |    |
|---------------------|-------|----------------|----------------|----|-----------|----|------------------------|----|-----------|----|-----------|----|------------------------|----|-------------------------------------|------|------------------------|------|--|------|-------------------------------------|------|---|------|---|------|--------------------------------------|------|--------------------------|------|-----|----|
|                     |       |                | A <sub>k</sub> | 0° | 30°       | 0° | 30°                    | 0° | 30°       | 0° | 30°       | 0° | 30°                    | 0° | 30°                                 | 0°   | 30°                    | 0°   | 30°  | 0°   | 30°                                 | 0°   | 30°   | 0°   | 30°   | 0°   | 30°                                  | 0°   | 30°                      | 0°   | 30° | 0° |
| (m <sup>3</sup> /h) | (l/s) | Ø              |                |    |           |    |                        |    |           |    |           |    |                        |    |                                     |      |                        |      |  |      |                                     |      |   |      |   |      |                                      |      |                          |      |     |    |
| 1200                | 333.3 | V <sub>k</sub> |                |    |           |    |                        |    |           |    |           |    |                        |    | 8.6                                 | 8.6  | 7.0                    | 7.0  | 5.6  | 5.6  | 4.1                                 | 4.1  | 3.4   | 3.4  | 2.7   | 2.7  | 2.2                                  | 2.2  | 1.6                      | 1.6  |     |    |
|                     |       | X              |                |    |           |    |                        |    |           |    |           |    |                        |    | 16.4                                | 13.1 | 14.7                   | 11.8 | 13.2   | 10.6 | 11.2                                | 8.9  | 10.1  | 8.1  | 9.2   | 7.4  | 8.3                                  | 6.6  | 7.0                      | 5.6  |     |    |
|                     |       | P <sub>t</sub> |                |    |           |    |                        |    |           |    |           |    |                        |    | 46.5                                | 55.9 | 30.6                   | 36.7 | 19.8   | 23.7 | 10.2                                | 12.2 | 6.9   | 8.3  | 4.7   | 4.7  | 3                                    | 3.6  | 1.6                      | 1.9  |     |    |
|                     |       | NR             |                |    |           |    |                        |    |           |    |           |    |                        |    | 43.2                                | 45.0 | 39.6                   | 41.4 | 36.0   | 37.8 | 29.7                                | 31.5 | 27.0  | 28.8 | 23.4  | 25.2 | 19.8                                 | 21.6 | 13.5                     | 15.3 |     |    |
| 1300                | 361.1 | V <sub>k</sub> |                |    |           |    |                        |    |           |    |           |    |                        |    | 9.4                                 | 9.4  | 7.6                    | 7.6  | 6.1  | 6.1  | 4.4                                 | 4.4  | 3.6   | 3.6  | 3.0   | 3.0  | 2.4                                  | 2.4  | 1.8                      | 1.8  |     |    |
|                     |       | X              |                |    |           |    |                        |    |           |    |           |    |                        |    | 17.7                                | 14.2 | 16.0                   | 12.8 | 14.3   | 11.4 | 12.1                                | 9.7  | 11.0  | 8.8  | 10.0  | 8.0  | 8.9                                  | 7.2  | 7.6                      | 6.1  |     |    |
|                     |       | P <sub>t</sub> |                |    |           |    |                        |    |           |    |           |    |                        |    | 43.7                                | 52.5 | 28.7                   | 34.5 | 18.6   | 22.3 | 9.6                                 | 11.5 | 6.5   | 7.8  | 4.4   | 5.4  | 2.9                                  | 3.4  | 1.5                      | 1.8  |     |    |
|                     |       | NR             |                |    |           |    |                        |    |           |    |           |    |                        |    | 45.0                                | 46.8 | 41.4                   | 43.2 | 37.8   | 39.6 | 31.5                                | 33.3 | 28.8  | 30.6 | 25.2  | 27.0 | 21.6                                 | 23.4 | 15.3                     | 17.1 |     |    |
| 1400                | 388.9 | V <sub>k</sub> |                |    |           |    |                        |    |           |    |           |    |                        |    | 10.1                                | 10.1 | 8.2                    | 8.2  | 6.6  | 6.6  | 4.7                                 | 4.7  | 3.9   | 3.9  | 3.2   | 3.2  | 2.6                                  | 2.6  | 1.8                      | 1.8  |     |    |
|                     |       | X              |                |    |           |    |                        |    |           |    |           |    |                        |    | 19.0                                | 15.3 | 17.2                   | 13.8 | 15.4   | 12.3 | 13.1                                | 10.5 | 11.9  | 9.5  | 10.8  | 8.6  | 9.7                                  | 7.7  | 8.3                      | 6.6  |     |    |
|                     |       | P <sub>t</sub> |                |    |           |    |                        |    |           |    |           |    |                        |    | 50.7                                | 60.8 | 33.4                   | 40.0 | 21.5   | 25.8 | 11.1                                | 13.4 | 7.5   | 9.0  | 5.1   | 6.2  | 3.3                                  | 4.0  | 1.8                      | 2.1  |     |    |
|                     |       | NR             |                |    |           |    |                        |    |           |    |           |    |                        |    | 46.8                                | 48.6 | 43.2                   | 45.0 | 39.6   | 41.4 | 33.3                                | 35.1 | 29.7  | 31.5 | 27.0  | 28.8 | 22.5                                 | 24.3 | 17.1                     | 18.9 |     |    |
| 1500                | 416.7 | V <sub>k</sub> |                |    |           |    |                        |    |           |    |           |    |                        |    |                                     |      |                        |      |  |      |                                     |      |   |      |   |      |                                      |      |                          |      |     |    |
|                     |       | X              |                |    |           |    |                        |    |           |    |           |    |                        |    |                                     |      |                        |      |  |      |                                     |      |   |      |   |      |                                      |      |                          |      |     |    |
|                     |       | P <sub>t</sub> |                |    |           |    |                        |    |           |    |           |    |                        |    |                                     |      |                        |      |  |      |                                     |      |   |      |   |      |                                      |      |                          |      |     |    |
|                     |       | NR             |                |    |           |    |                        |    |           |    |           |    |                        |    |                                     |      |                        |      |  |      |                                     |      |   |      |   |      |                                      |      |                          |      |     |    |
| 1600                | 444.4 | V <sub>k</sub> |                |    |           |    |                        |    |           |    |           |    |                        |    |                                     |      |                        |      |  |      |                                     |      |   |      |   |      |                                      |      |                          |      |     |    |
|                     |       | X              |                |    |           |    |                        |    |           |    |           |    |                        |    |                                     |      |                        |      |  |      |                                     |      |   |      |   |      |                                      |      |                          |      |     |    |
|                     |       | P <sub>t</sub> |                |    |           |    |                        |    |           |    |           |    |                        |    |                                     |      |                        |      |  |      |                                     |      |   |      |   |      |                                      |      |                          |      |     |    |
|                     |       | NR             |                |    |           |    |                        |    |           |    |           |    |                        |    |                                     |      |                        |      |  |      |                                     |      |   |      |   |      |                                      |      |                          |      |     |    |
| 1700                | 472.2 | V <sub>k</sub> |                |    |           |    |                        |    |           |    |           |    |                        |    |                                     |      |                        |      |  |      |                                     |      |   |      |   |      |                                      |      |                          |      |     |    |
|                     |       | X              |                |    |           |    |                        |    |           |    |           |    |                        |    |                                     |      |                        |      |  |      |                                     |      |   |      |   |      |                                      |      |                          |      |     |    |
|                     |       | P <sub>t</sub> |                |    |           |    |                        |    |           |    |           |    |                        |    |                                     |      |                        |      |  |      |                                     |      |   |      |   |      |                                      |      |                          |      |     |    |
|                     |       | NR             |                |    |           |    |                        |    |           |    |           |    |                        |    |                                     |      |                        |      |  |      |                                     |      |   |      |   |      |                                      |      |                          |      |     |    |
| 1800                | 500.0 | V <sub>k</sub> |                |    |           |    |                        |    |           |    |           |    |                        |    |                                     |      |                        |      |  |      |                                     |      |   |      |   |      |                                      |      |                          |      |     |    |
|                     |       | X              |                |    |           |    |                        |    |           |    |           |    |                        |    |                                     |      |                        |      |  |      |                                     |      |   |      |   |      |                                      |      |                          |      |     |    |
|                     |       | P <sub>t</sub> |                |    |           |    |                        |    |           |    |           |    |                        |    |                                     |      |                        |      |  |      |                                     |      |   |      |   |      |                                      |      |                          |      |     |    |
|                     |       | NR             |                |    |           |    |                        |    |           |    |           |    |                        |    |                                     |      |                        |      |  |      |                                     |      |   |      |   |      |                                      |      |                          |      |     |    |
| 1900                | 527.8 | V <sub>k</sub> |                |    |           |    |                        |    |           |    |           |    |                        |    |                                     |      |                        |      |  |      |                                     |      |   |      |   |      |                                      |      |                          |      |     |    |
|                     |       | X              |                |    |           |    |                        |    |           |    |           |    |                        |    |                                     |      |                        |      |  |      |                                     |      |   |      |   |      |                                      |      |                          |      |     |    |
|                     |       | P <sub>t</sub> |                |    |           |    |                        |    |           |    |           |    |                        |    |                                     |      |                        |      |  |      |                                     |      |   |      |   |      |                                      |      |                          |      |     |    |
|                     |       | NR             |                |    |           |    |                        |    |           |    |           |    |                        |    |                                     |      |                        |      |  |      |                                     |      |   |      |   |      |                                      |      |                          |      |     |    |
| 2000                | 555.6 | V <sub>k</sub> |                |    |           |    |                        |    |           |    |           |    |                        |    |                                     |      |                        |      |  |      |                                     |      |   |      |   |      |                                      |      |                          |      |     |    |
|                     |       | X              |                |    |           |    |                        |    |           |    |           |    |                        |    |                                     |      |                        |      |  |      |                                     |      |   |      |   |      |                                      |      |                          |      |     |    |
|                     |       | P <sub>t</sub> |                |    |           |    |                        |    |           |    |           |    |                        |    |                                     |      |                        |      |  |      |                                     |      |   |      |   |      |                                      |      |                          |      |     |    |
|                     |       | NR             |                |    |           |    |                        |    |           |    |           |    |                        |    |                                     |      |                        |      |  |      |                                     |      |   |      |   |      |                                      |      |                          |      |     |    |
| 2100                | 583.3 | V <sub>k</sub> |                |    |           |    |                        |    |           |    |           |    |                        |    |                                     |      |                        |      |  |      |                                     |      |   |      |   |      |                                      |      |                          |      |     |    |
|                     |       | X              |                |    |           |    |                        |    |           |    |           |    |                        |    |                                     |      |                        |      |  |      |                                     |      |   |      |   |      |                                      |      |                          |      |     |    |
|                     |       | P <sub>t</sub> |                |    |           |    |                        |    |           |    |           |    |                        |    |                                     |      |                        |      |  |      |                                     |      |   |      |   |      |                                      |      |                          |      |     |    |
|                     |       | NR             |                |    |           |    |                        |    |           |    |           |    |                        |    |                                     |      |                        |      |  |      |                                     |      |   |      |   |      |                                      |      |                          |      |     |    |



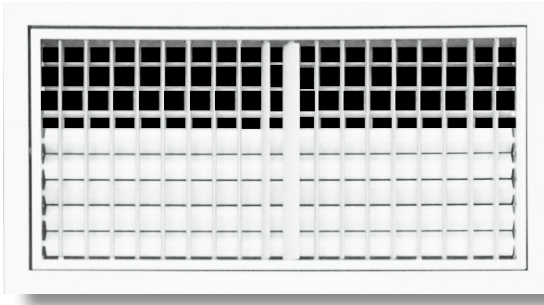
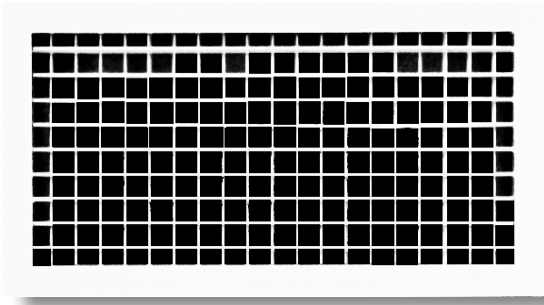

# Double Deflection Grille

**General Information:**

For supply air, having a single set of fully adjustable blades to give directional control of the air pattern in four directions if required. Suitable for wall or duct mounting. Also available with curved face for circular duct installations.

From extruded aluminium sections, ensuring functional strength and performance that also gives an attractive and aesthetically pleasing appearance. Incorporating two set of individually adjustable blades, the blades may be set either horizontally or at angles, either up or down. Rear blades are adjusted in a similar way but only in a vertical plane. Powder coated white as standard with optional colors and finishes available on request.

**Features:**

- Aluminium grilles, adjustable blades
- Powder coated white as standard
- H,L: Nominal ordering sizes (duct opening size)
- Designation: Vertical front blades & Horizontal front blade
- Accessories: Sub frame SFR, Volume control damper, OBD, CLIP mounting clips for sub frame
- Size manufactured on request
- Blades are movable on horizontal and vertical lines.

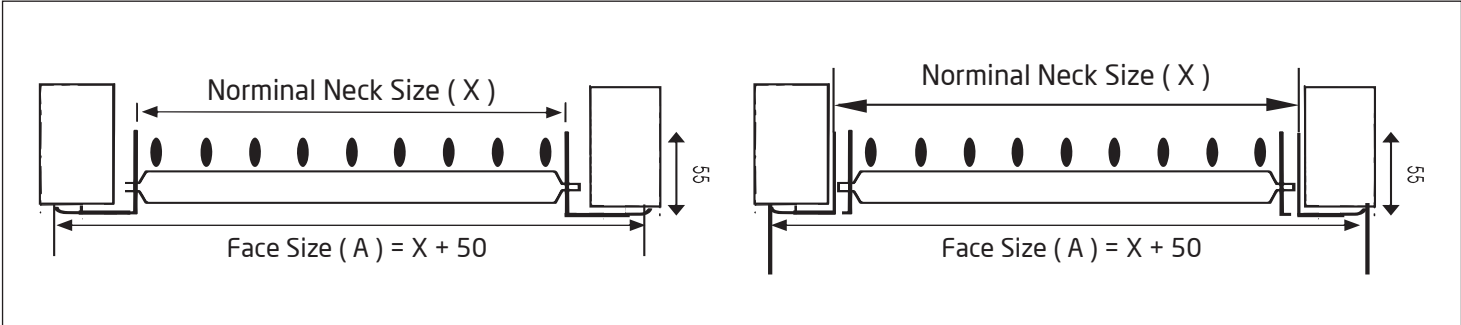

## General notes on the quick selection table:

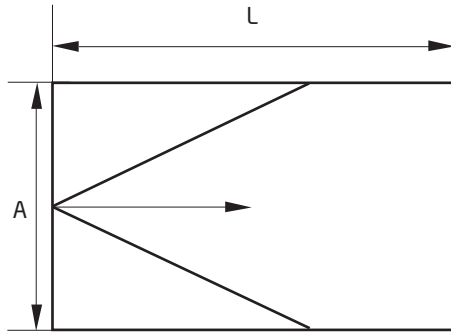

Fig 1

Some correction factors exist as a function of the ratio between room width and length, the blade deflection angle and the distance from grille to ceiling, and are defined in the following manner:

**A/L:** Ratio between the width and the length of the room to be conditioned. For example, for a room with a width of 4.5m and length of 4.5m the factor A/L equals 1 (see fig 1).

**C<sub>a</sub>:** Factor obtained from the graph. For example, if the value of A/L = 1 and for a grille with 0° blade angle, the value of C<sub>a</sub> equals 1.3 (see fig 2).

**C<sub>h</sub>:** Correction factor for height, obtained from the distance between grille and ceiling.

For a free jet C<sub>h</sub> is always 1.1.

For example, if the grille is located at 0.2m from the ceiling the factor C<sub>h</sub> equals 1 (see fig 3&4).

Once calculated, the correction factor for the throw (K<sub>c</sub>) can be determined by the following formula:

$$K_c = C_a * C_h$$

$$K_c = 1.3 * 1$$

In this case of selection by table, we would obtain the correction throw (X<sub>c</sub>):

$$X_c = K_c * X$$

$$X_c = 1.3 * X$$

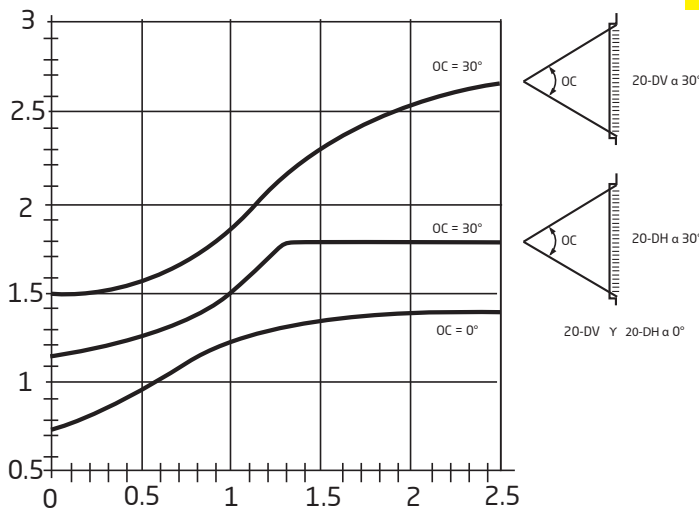

Fig 2

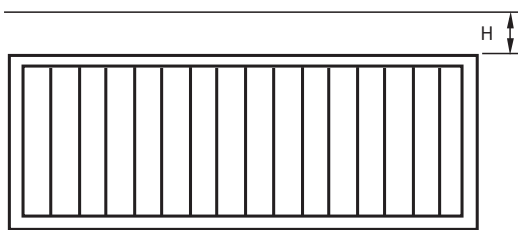

Fig 3

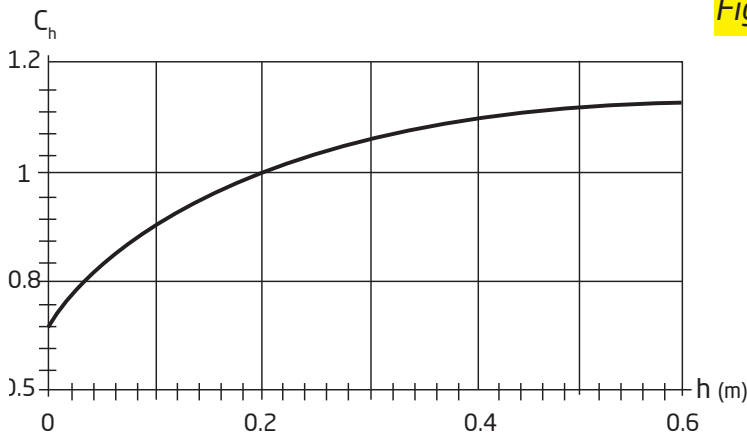

Fig 4

## Quick Selection Table

Symbols:

A<sub>k</sub> - Effective area

V<sub>k</sub> - Effective velocity in m/s

X - Throw in metres correspond to a terminal velocity in occupied zone of 0.25m/s

Pressure (P<sub>t</sub>) - All pressures are in Pa (N/m<sup>2</sup>)

NR - Noise level index in dB based on a room absorption and one diffuser

**Quick Selection Table**

| Flow rate           |       | Dim            | 200 x 100      |         | 250 x 100 |         | 300 x 100<br>200 x 150 |        | 250 x 150 |        | 300 x 150 |        | 350 x 150<br>250 x 200 |        | 600 x 100<br>400 x 150<br>300 x 200 |        | 500 x 150<br>350 x 200 |        | 600 x 150<br>450 x 200<br>350 x 250<br>300 x 300 |        | 600 x 200<br>500 x 250<br>400 x 300 |        | 1000 x 150<br>750 x 200<br>600 x 250<br>500 x 300 |        | 1200 x 150<br>900 x 200<br>750 x 250<br>600 x 300 |        | 1100 x 200<br>900 x 250<br>750 x 300 |        | 1200 x 250<br>1000 x 300 |        |
|---------------------|-------|----------------|----------------|---------|-----------|---------|------------------------|--------|-----------|--------|-----------|--------|------------------------|--------|-------------------------------------|--------|------------------------|--------|--|--------|-------------------------------------|--------|---|--------|---|--------|--------------------------------------|--------|--------------------------|--------|
|                     |       |                | A <sub>k</sub> | 0.00098 |           | 0.00125 |                        | 0.0148 |           | 0.0183 |           | 0.0224 |                        | 0.0262 |                                     | 0.0309 |                        | 0.0381 |  | 0.0474 |                                     | 0.0660 |   | 0.0801 |   | 0.0970 |                                      | 0.1210 |                          | 0.1670 |
| (m <sup>3</sup> /h) | (l/s) | Ø              | 0°             | 30°     | 0°        | 30°     | 0°                     | 30°    | 0°        | 30°    | 0°        | 30°    | 0°                     | 30°    | 0°                                  | 30°    | 0°                     | 30°    | 0°   | 30°    | 0°                                  | 30°    | 0°  | 30°    | 0°  | 30°    | 0°                                   | 30°    | 0°                       | 30°    |
| 100                 | 27.8  | V <sub>k</sub> | 2.8            | 2.8     | 2.2       | 2.2     | 1.9                    | 1.9    | 1.5       | 1.5    | 1.2       | 1.2    | 1.1                    | 1.1    | 0.9                                 | 0.9    | 0.7                    | 0.7    | 0.6  | 0.6    |                                     |        |   |        |   |        |                                      |        |                          |        |
|                     |       | X              | 2.2            | 1.8     | 1.9       | 1.6     | 1.8                    | 1.4    | 1.6       | 1.3    | 1.5       | 1.2    | 1.3                    | 1.1    | 1.2                                 | 1      | 1.1                    | 0.9    | 1  | 0.8    |                                     |        |   |        |   |        |                                      |        |                          |        |
|                     |       | P <sub>t</sub> | 3.2            | 3.9     | 2         | 2.4     | 1.4                    | 1.7    | 0.9       | 1.1    | 0.6       | 0.7    | 0.4                    | 0.5    | 0.3                                 | 0.4    | 0.2                    | 0.3    | 0.1  | 0.2    |                                     |        |   |        |   |        |                                      |        |                          |        |
|                     |       | NR             | 10             | 12      | 5         | 7       | -                      | -      | -         | -      | -         | -      | -                      | -      | -                                   | -      | -                      | -      | -  | -      | -                                   |        |   |        |   |        |                                      |        |                          |        |
| 150                 | 41.7  | V <sub>k</sub> | 4.3            | 4.3     | 3.3       | 3.3     | 2.8                    | 2.8    | 2.3       | 2.3    | 1.9       | 1.9    | 1.6                    | 1.6    | 1.3                                 | 1.3    | 1.1                    | 1.1    | 0.9  | 0.9    | 0.6                                 | 0.6    |   |        |   |        |                                      |        |                          |        |
|                     |       | X              | 3.3            | 2.6     | 2.9       | 2.3     | 2.7                    | 2.1    | 2.4       | 1.9    | 2.2       | 1.7    | 2                      | 1.6    | 1.9                                 | 1.5    | 1.7                    | 1.3    | 1.5  | 1.2    | 1.3                                 | 1      |   |        |   |        |                                      |        |                          |        |
|                     |       | P <sub>t</sub> | 7.2            | 8.7     | 4.4       | 5.3     | 3.2                    | 3.8    | 2.1       | 2.5    | 1.4       | 1.7    | 1                      | 1.2    | 0.7                                 | 0.9    | 0.5                    | 0.6    | 0.3  | 0.4    | 0.2                                 | 0.2    |   |        |   |        |                                      |        |                          |        |
|                     |       | NR             | 20             | 22      | 15        | 17      | 12                     | 14     | 8         | 10     | 4         | 6      | -                      | -      | -                                   | -      | -                      | -      | -  | -      | -                                   | -      | -   |        |   |        |                                      |        |                          |        |
| 200                 | 55.6  | V <sub>k</sub> | 5.7            | 5.7     | 4.4       | 4.4     | 3.8                    | 3.8    | 3         | 3      | 2.5       | 2.5    | 2.1                    | 2.1    | 1.8                                 | 1.8    | 1.5                    | 1.5    | 1.2  | 1.2    | 0.8                                 | 0.8    | 0.7   | 0.7    |   |        |                                      |        |                          |        |
|                     |       | X              | 4.4            | 3.5     | 3.9       | 3.1     | 3.6                    | 2.9    | 3.2       | 2.6    | 2.9       | 2.3    | 2.7                    | 2.2    | 2.5                                 | 2      | 2.2                    | 1.8    | 2  | 1.6    | 1.7                                 | 1.4    | 1.5   | 1.2    |   |        |                                      |        |                          |        |
|                     |       | P <sub>t</sub> | 12.9           | 15.4    | 7.9       | 9.5     | 5.6                    | 6.8    | 3.7       | 4.4    | 2.5       | 3      | 1.8                    | 2.2    | 1.3                                 | 1.6    | 0.9                    | 1      | 0.5  | 0.7    | 0.3                                 | 0.3    | 0.2   | 0.2    |   |        |                                      |        |                          |        |
|                     |       | NR             | 27             | 29      | 22        | 24      | 19                     | 21     | 15        | 17     | 11        | 13     | 8                      | 10     | 5                                   | 7      | -                      | -      | -  | -      | -                                   | -      | -   | -      |   |        |                                      |        |                          |        |
| 250                 | 69.4  | V <sub>k</sub> | 7.1            | 7.1     | 5.6       | 5.6     | 4.7                    | 4.7    | 3.8       | 3.8    | 3.1       | 3.1    | 2.7                    | 2.7    | 2.2                                 | 2.2    | 1.8                    | 1.8    | 1.5  | 1.5    | 1.1                                 | 1.1    | 0.9   | 0.9    |   |        |                                      |        |                          |        |
|                     |       | X              | 5.5            | 4.4     | 4.9       | 3.9     | 4.5                    | 3.6    | 4         | 3.2    | 3.6       | 2.9    | 5.3                    | 2.7    | 3.1                                 | 2.5    | 2.8                    | 2.2    | 2.5  | 2      | 2.1                                 | 1.7    | 1.9   | 1.5    |   |        |                                      |        |                          |        |
|                     |       | P <sub>t</sub> | 20.1           | 24.1    | 12.3      | 14.8    | 8.8                    | 10.6   | 5.8       | 6.9    | 3.8       | 4.6    | 2.8                    | 3.4    | 2                                   | 2.4    | 1.3                    | 1.6    | 0.9  | 1      | 0.4                                 | 0.5    | 0.3   | 0.4    |   |        |                                      |        |                          |        |
|                     |       | NR             | 33             | 35      | 28        | 30      | 24                     | 26     | 20        | 22     | 16        | 18     | 13                     | 15     | 10                                  | 12     | 6                      | 8      | -  | -      | -                                   | -      | -   | -      |   |        |                                      |        |                          |        |
| 300                 | 83.3  | V <sub>k</sub> | 8.5            | 8.5     | 6.7       | 6.7     | 5.6                    | 5.6    | 4.6       | 4.6    | 3.7       | 3.7    | 3.2                    | 3.2    | 2.7                                 | 2.7    | 2.2                    | 2.2    | 1.8  | 1.8    | 1.3                                 | 1.3    | 1   | 1      | 0.9   | 0.9    |                                      |        |                          |        |
|                     |       | X              | 6.6            | 5.3     | 5.8       | 4.7     | 5.4                    | 4.3    | 4.8       | 3.9    | 4.4       | 3.5    | 4                      | 3.2    | 3.7                                 | 3      | 3.3                    | 2.7    | 3  | 2.4    | 2.5                                 | 2      | 2.3   | 1.8    | 2.1   | 1.7    |                                      |        |                          |        |
|                     |       | P <sub>t</sub> | 28.9           | 34.7    | 17.8      | 21.3    | 12.7                   | 15.2   | 8.3       | 10     | 5.5       | 6.6    | 4                      | 4.9    | 2.9                                 | 3.5    | 1.9                    | 2.3    | 1.2  | 1.5    | 0.6                                 | 0.8    | 0.4   | 0.5    | 0.3   | 0.4    |                                      |        |                          |        |
|                     |       | NR             | 37             | 39      | 32        | 34      | 29                     | 31     | 25        | 27     | 21        | 23     | 18                     | 20     | 15                                  | 17     | 10                     | 12     | 6  | 8      | -                                   | -      | -   | -      | -   | -      |                                      |        |                          |        |
| 350                 | 97.2  | V <sub>k</sub> | 9.9            | 9.9     | 7.8       | 7.8     | 6.6                    | 6.6    | 5.3       | 5.3    | 4.3       | 4.3    | 3.7                    | 3.7    | 3.1                                 | 3.1    | 2.6                    | 2.6    | 2.1  | 2.1    | 1.5                                 | 1.5    | 1.2   | 1.2    | 1   | 1      |                                      |        |                          |        |
|                     |       | X              | 7.7            | 6.2     | 6.8       | 5.5     | 6.3                    | 5      | 5.6       | 4.5    | 5.1       | 4.1    | 4.7                    | 3.8    | 4.3                                 | 3.5    | 3.9                    | 3.1    | 3.5  | 2.8    | 3                                   | 2.4    | 2.7   | 2.2    | 2.4   | 2      |                                      |        |                          |        |
|                     |       | P <sub>t</sub> | 39.4           | 47.2    | 24.2      | 29      | 17.3                   | 20.7   | 11.3      | 13.5   | 7.5       | 9      | 5.5                    | 6.6    | 4                                   | 4.8    | 2.6                    | 3.1    | 1.7  | 2      | 0.9                                 | 1      | 0.6   | 0.7    | 0.4   | 0.5    |                                      |        |                          |        |
|                     |       | NR             | 41             | 43      | 36        | 38      | 33                     | 35     | 29        | 31     | 25        | 27     | 21                     | 23     | 18                                  | 20     | 14                     | 16     | 10   | 12     | -                                   | -      | -   | -      | -   | -      |                                      |        |                          |        |
| 400                 | 111.1 | V <sub>k</sub> | 11.3           | 11.3    | 8.9       | 8.9     | 7.5                    | 7.5    | 6.1       | 6.1    | 5         | 5      | 4.2                    | 4.2    | 3.6                                 | 3.6    | 2.9                    | 2.9    | 2.3  | 2.3    | 1.7                                 | 1.7    | 1.4   | 1.4    | 1.1   | 1.1    | 0.9                                  | 0.9    |                          |        |
|                     |       | X              | 8.8            | 7       | 7.8       | 6.2     | 7.2                    | 5.7    | 6.4       | 5.1    | 5.8       | 4.7    | 5.4                    | 4.3    | 5                                   | 4      | 4.5                    | 3.6    | 4  | 3.2    | 3.4                                 | 2.7    | 3.1   | 2.5    | 2.8   | 2.2    | 2.5                                  | 2      |                          |        |
|                     |       | P <sub>t</sub> | 51.4           | 61.7    | 31.6      | 37.9    | 22.5                   | 27.1   | 14.7      | 17.7   | 9.8       | 11.8   | 7.2                    | 8.6    | 5.2                                 | 6.2    | 3.4                    | 4.1    | 2.2  | 2.6    | 1.1                                 | 1.4    | 0.8   | 0.9    | 0.5   | 0.6    | 0.3                                  | 0.4    |                          |        |
|                     |       | NR             | 44             | 46      | 39        | 41      | 36                     | 38     | 32        | 34     | 28        | 30     | 25                     | 27     | 22                                  | 24     | 17                     | 19     | 13   | 15     | 7                                   | 9      | -   | -      | -   | -      | -                                    | -      |                          |        |
| 450                 | 125.0 | V <sub>k</sub> |                |         | 10        | 10      | 8.4                    | 8.4    | 6.8       | 6.8    | 5.6       | 5.6    | 4.8                    | 4.8    | 4                                   | 4      | 3.3                    | 3.3    | 2.6  | 2.6    | 1.9                                 | 1.9    | 1.6   | 1.6    | 1.3   | 1.3    | 1                                    | 1      |                          |        |
|                     |       | X              |                |         | 8.8       | 7       | 8.1                    | 6.4    | 7.2       | 5.8    | 6.5       | 5.2    | 6.1                    | 4.8    | 5.6                                 | 4.5    | 5                      | 4      | 4.5  | 3.6    | 3.8                                 | 3.1    | 3.5   | 2.8    | 3.1   | 2.5    | 2.8                                  | 2.3    |                          |        |
|                     |       | P <sub>t</sub> |                |         | 40        | 48      | 28.5                   | 34.2   | 18.7      | 22.4   | 12.5      | 14.9   | 9.1                    | 10.9   | 6.5                                 | 7.9    | 4.3                    | 5.2    | 2.8  | 3.3    | 1.4                                 | 1.7    | 1   | 1.2    | 0.7   | 0.8    | 0.4                                  | 0.5    |                          |        |
|                     |       | NR             |                |         | 42        | 44      | 39                     | 41     | 35        | 37     | 31        | 33     | 28                     | 30     | 24                                  | 26     | 20                     | 22     | 16   | 18     | 10                                  | 12     | 6   | 8      | -   | -      | -                                    | -      |                          |        |
| 500                 | 138.9 | V <sub>k</sub> |                |         | 11.1      | 11.1    | 9.4                    | 9.4    | 7.6       | 7.6    | 6.2       | 6.2    | 5.3                    | 5.3    | 4.5                                 | 4.5    | 3.6                    | 3.6    | 2.9  | 2.9    | 2.1                                 | 2.1    | 1.7   | 1.7    | 1.4   | 1.4    | 1.1                                  | 1.1    | 0.8                      | 0.8    |
|                     |       | X              |                |         | 9.7       | 7.8     | 8.9                    | 7.2    | 8         | 6.4    | 7.3       | 5.8    | 6.7                    | 5.4    | 6.2                                 | 5      | 5.6                    | 4.5    | 5  | 4      | 4.2                                 | 3.4    | 3.8   | 3.1    | 3.5   | 2.8    | 3.1                                  | 2.5    | 2.7                      | 2.10   |
|                     |       | P <sub>t</sub> |                |         | 49.4      | 59.3    | 35.2                   | 42.3   | 23        | 27.6   | 15.4      | 18.5   | 11.2                   | 13.5   | 8.1                                 | 9.7    | 5.3                    | 6.4    | 3.4  | 4.1    | 1.8                                 | 2.1    | 1.2   | 1.4    | 0.8   | 1      | 0.5                                  | 0.6    | 0.3                      | 0.3    |
|                     |       | NR             |                |         | 41        | 43      | 37                     | 39     | 33        | 35     | 30        | 32     | 27                     | 29     | 23                                  | 25     | 19                     | 21     | 12   | 14     | 8                                   | 10     | 5   | 7      | -   | -      | -                                    | -      |                          |        |
| 550                 | 152.8 | V <sub>k</sub> |                |         |           |         | 10.3                   | 10.3   | 8.3       | 8.3    | 6.8       | 6.8    | 5.8                    | 5.8    | 4.9                                 | 4.9    | 4                      | 4      | 3.2  | 3.2    | 2.3                                 | 2.3    | 1.9   | 1.9    | 1.6   | 1.6    | 1.3                                  | 1.3    | 0.9                      | 0.9    |
|                     |       | X              |                |         |           |         | 9.8                    | 7.9    | 8.9       | 7.1    | 8         | 6.4    | 7.4                    | 5.9    | 6.8                                 | 5.4    | 6.1                    | 4.9    | 5.5  | 4.4    | 4.7                                 | 3.7    | 4.2   | 3.4    | 3.8   | 3.1    | 3.4                                  | 2.8    | 2.9                      | 2.3    |
|                     |       | P <sub>t</sub> |                |         |           |         | 42.6                   | 51.1   | 27.9      | 33.5   | 18.6      | 22.3   | 13.6                   | 16.3   | 9.8                                 | 11.7   | 6.4                    | 7.7    | 4.2  | 5      | 2.1                                 | 2.6    | 1.5   | 1.7    | 1   | 1.2    | 0.6                                  | 0.8    | 0.3                      | 0.4    |
|                     |       | NR             |                |         |           |         | 44                     | 46     | 39        | 41     | 36        | 38     | 32                     | 34     | 29                                  | 31     | 25                     | 27     | 21   | 23     | 14                                  | 16     | 11  | 13     | 7   | 9      | -                                    | -      | -                        | -      |

## Quick Selection Table

| Flow rate           |       | Dim            | 200 x 100      |         | 250 x 100 |         | 300 x 100<br>200 x 150 |        | 250 x 150 |        | 300 x 150 |        | 350 x 150<br>250 x 200 |        | 600 x 100<br>400 x 150<br>300 x 200 |        | 500 x 150<br>350 x 200 |        | 600 x 150<br>450 x 200<br>350 x 250<br>300 x 300 |        | 600 x 200<br>500 x 250<br>400 x 300 |        | 1000 x 150<br>750 x 200<br>600 x 250<br>500 x 300 |        | 1200 x 150<br>900 x 200<br>750 x 250<br>600 x 300 |        | 1100 x 200<br>900 x 250<br>750 x 300 |        | 1200 x 250<br>1000 x 300 |        |
|---------------------|-------|----------------|----------------|---------|-----------|---------|------------------------|--------|-----------|--------|-----------|--------|------------------------|--------|-------------------------------------|--------|------------------------|--------|--|--------|-------------------------------------|--------|---|--------|---|--------|--------------------------------------|--------|--------------------------|--------|
|                     |       |                | A <sub>k</sub> | 0.00098 |           | 0.00125 |                        | 0.0148 |           | 0.0183 |           | 0.0224 |                        | 0.0262 |                                     | 0.0309 |                        | 0.0381 |  | 0.0474 |                                     | 0.0660 |   | 0.0801 |   | 0.0970 |                                      | 0.1210 |                          | 0.1670 |
| (m <sup>3</sup> /h) | (l/s) | Ø              | 0°             | 30°     | 0°        | 30°     | 0°                     | 30°    | 0°        | 30°    | 0°        | 30°    | 0°                     | 30°    | 0°                                  | 30°    | 0°                     | 30°    | 0°   | 30°    | 0°                                  | 30°    | 0°  | 30°    | 0°  | 30°    | 0°                                   | 30°    | 0°                       | 30°    |
| 600                 | 166.7 | V <sub>k</sub> |                |         |           |         | 11.3                   | 11.3   | 9.1       | 9.1    | 8.4       | 7.4    | 6.4                    | 6.4    | 5.4                                 | 5.4    | 4.4                    | 4.4    | 3.5  | 3.5    | 2.5                                 | 2.5    | 2.1   | 2.1    | 1.7   | 1.7    | 1.4                                  | 1.4    | 1                        | 1      |
|                     |       | X              |                |         |           |         | 10.7                   | 8.6    | 9.7       | 7.7    | 8.7       | 7      | 8.1                    | 6.5    | 7.4                                 | 5.9    | 6.7                    | 5.4    | 6  | 4.8    | 5.1                                 | 4.1    | 4.6   | 3.7    | 4.2   | 3.4    | 3.8                                  | 3      | 3.2                      | 2.6    |
|                     |       | P <sub>t</sub> |                |         |           |         | 50.7                   | 60.9   | 33.2      | 39.8   | 22.1      | 26.6   | 16.2                   | 19.4   | 11.6                                | 14     | 7.7                    | 9.2    | 4.9  | 5.9    | 2.6                                 | 3.1    | 1.7   | 2.1    | 1.2   | 1.4    | 0.8                                  | 0.9    | 0.4                      | 0.5    |
|                     |       | NR             |                |         |           |         | 46                     | 48     | 42        | 44     | 38        | 40     | 35                     | 37     | 31                                  | 33     | 27                     | 29     | 23   | 25     | 17                                  | 19     | 13  | 15     | 9   | 11     | 5                                    | 7      | -                        | -      |
| 650                 | 180.6 | V <sub>k</sub> |                |         |           |         | 12.2                   | 12.2   | 9.9       | 9.9    | 8.1       | 8.1    | 6.9                    | 6.9    | 5.8                                 | 5.8    | 4.7                    | 4.7    | 3.8  | 3.8    | 2.7                                 | 2.7    | 2.3   | 2.3    | 2.9   | 1.9    | 1.5                                  | 1.5    | 1.1                      | 1.1    |
|                     |       | X              |                |         |           |         | 11.6                   | 9.3    | 10.5      | 8.4    | 9.5       | 7.6    | 8.7                    | 7      | 8                                   | 6.4    | 7.2                    | 5.8    | 6.5  | 5.2    | 5.5                                 | 4.4    | 5   | 4      | 4.5   | 3.6    | 4.1                                  | 3.3    | 3.5                      | 2.8    |
|                     |       | P <sub>t</sub> |                |         |           |         | 59.5                   | 71.4   | 38.9      | 46.7   | 26        | 31.2   | 19                     | 22.8   | 13.7                                | 16.4   | 9                      | 10.8   | 5.8  | 7      | 3                                   | 3.6    | 2   | 2.4    | 1.4   | 1.7    | 0.9                                  | 1.1    | 0.5                      | 0.6    |
|                     |       | NR             |                |         |           |         | 48                     | 50     | 44        | 46     | 40        | 42     | 37                     | 39     | 33                                  | 35     | 29                     | 31     | 25   | 27     | 18                                  | 20     | 15  | 17     | 11  | 13     | 7                                    | 9      | -                        | -      |
| 700                 | 194.4 | V <sub>k</sub> |                |         |           |         |                        |        | 10.6      | 10.6   | 8.7       | 8.7    | 7.4                    | 7.4    | 6.3                                 | 6.3    | 5.1                    | 5.1    | 4.1  | 4.1    | 2.9                                 | 2.9    | 2.4   | 2.4    | 2   | 2      | 1.6                                  | 1.6    | 1.2                      | 1.2    |
|                     |       | X              |                |         |           |         |                        |        | 11.3      | 9      | 10.2      | 8.1    | 9.4                    | 7.5    | 8.7                                 | 6.9    | 7.8                    | 6.2    | 7  | 5.6    | 5.9                                 | 4.7    | 5.4   | 4.3    | 4.9   | 3.9    | 4.4                                  | 3.5    | 3.7                      | 3      |
|                     |       | P <sub>t</sub> |                |         |           |         |                        |        | 45.2      | 54.2   | 30.1      | 36.2   | 22                     | 26.4   | 15.8                                | 19     | 10.4                   | 12.5   | 6.7  | 8.1    | 3.5                                 | 4.2    | 2.4   | 2.8    | 1.6   | 1.9    | 1                                    | 1.2    | 0.5                      | 0.7    |
|                     |       | NR             |                |         |           |         |                        |        | 45        | 47     | 41        | 43     | 38                     | 40     | 35                                  | 37     | 31                     | 33     | 27   | 29     | 20                                  | 22     | 17  | 19     | 13  | 15     | 8                                    | 10     | -                        | -      |
| 750                 | 208.3 | V <sub>k</sub> |                |         |           |         |                        |        | 11.4      | 11.4   | 9.3       | 9.3    | 8                      | 8      | 6.7                                 | 6.7    | 5.5                    | 5.5    | 4.4  | 4.4    | 3.2                                 | 3.2    | 2.6   | 2.6    | 2.1   | 2.1    | 1.7                                  | 1.7    | 1.2                      | 1.2    |
|                     |       | X              |                |         |           |         |                        |        | 12.1      | 9.7    | 10.9      | 8.7    | 10.1                   | 8.1    | 9.3                                 | 7.4    | 8.4                    | 6.7    | 7.5  | 6      | 6.4                                 | 5.1    | 5.8   | 4.6    | 5.2   | 4.2    | 4.7                                  | 3.8    | 4                        | 3.2    |
|                     |       | P <sub>t</sub> |                |         |           |         |                        |        | 51.8      | 62.2   | 34.6      | 41.5   | 25.3                   | 30.3   | 18.2                                | 21.8   | 12                     | 14.4   | 7.7  | 9.3    | 4                                   | 4.8    | 2.7   | 3.2    | 1.8   | 2.2    | 1.2                                  | 1.4    | 0.6                      | 0.7    |
|                     |       | NR             |                |         |           |         |                        |        | 47        | 49     | 43        | 45     | 40                     | 42     | 37                                  | 39     | 33                     | 35     | 28   | 30     | 22                                  | 24     | 18  | 20     | 14  | 16     | 10                                   | 12     | -                        | -      |
| 800                 | 222.2 | V <sub>k</sub> |                |         |           |         |                        |        | 12.1      | 12.1   | 9.9       | 9.9    | 8.5                    | 8.5    | 7.2                                 | 7.2    | 5.8                    | 5.8    | 4.7  | 4.7    | 3.4                                 | 3.4    | 2.8   | 2.8    | 2.3   | 2.3    | 1.8                                  | 1.8    | 1.3                      | 1.3    |
|                     |       | X              |                |         |           |         |                        |        | 12.9      | 10.3   | 11.6      | 9.3    | 10.8                   | 8.6    | 9.9                                 | 7.9    | 8.9                    | 7.1    | 8  | 6.4    | 6.8                                 | 5.4    | 6.2   | 4.9    | 5.6   | 4.5    | 5                                    | 4      | 4.3                      | 3.4    |
|                     |       | P <sub>t</sub> |                |         |           |         |                        |        | 59        | 70.8   | 39.4      | 47.2   | 28.8                   | 34.5   | 20.7                                | 24.8   | 13.6                   | 16.3   | 8.8  | 10.6   | 4.5                                 | 5.4    | 3.1   | 3.7    | 2.1   | 2.5    | 1.3                                  | 1.6    | 0.7                      | 0.8    |
|                     |       | NR             |                |         |           |         |                        |        | 49        | 51     | 45        | 47     | 42                     | 44     | 38                                  | 40     | 34                     | 36     | 30   | 32     | 24                                  | 26     | 20  | 22     | 16  | 18     | 12                                   | 14     | -                        | -      |
| 850                 | 236.1 | V <sub>k</sub> |                |         |           |         |                        |        |           |        | 10.5      | 10.5   | 9                      | 9      | 7.6                                 | 7.6    | 6.2                    | 6.2    | 5  | 5      | 3.6                                 | 3.6    | 2.9   | 2.9    | 2.4   | 2.4    | 2                                    | 2      | 1.4                      | 1.4    |
|                     |       | X              |                |         |           |         |                        |        |           |        | 12.4      | 9.9    | 11.4                   | 9.1    | 10.5                                | 8.4    | 9.5                    | 7.6    | 8.5  | 6.8    | 7.2                                 | 5.8    | 6.5   | 5.2    | 5.9   | 4.8    | 5.3                                  | 4.3    | 4.5                      | 3.6    |
|                     |       | P <sub>t</sub> |                |         |           |         |                        |        |           |        | 44.4      | 53.3   | 32.5                   | 39     | 23.4                                | 28     | 15.4                   | 18.4   | 9.9  | 11.9   | 5.1                                 | 6.1    | 3.5   | 4.2    | 2.4   | 2.8    | 1.5                                  | 1.8    | 0.8                      | 1      |
|                     |       | NR             |                |         |           |         |                        |        |           |        | 46        | 48     | 43                     | 45     | 40                                  | 42     | 36                     | 38     | 31   | 33     | 25                                  | 27     | 21  | 23     | 17  | 19     | 13                                   | 15     | 7                        | 9      |
| 900                 | 250.0 | V <sub>k</sub> |                |         |           |         |                        |        |           |        | 11.2      | 11.2   | 9.5                    | 9.5    | 8.1                                 | 8.1    | 6.6                    | 6.6    | 5.3  | 5.3    | 3.8                                 | 3.8    | 3.1   | 3.1    | 2.6   | 2.6    | 2.1                                  | 2.1    | 1.5                      | 1.5    |
|                     |       | X              |                |         |           |         |                        |        |           |        | 13.1      | 10.5   | 12.1                   | 9.7    | 11.1                                | 8.9    | 10                     | 8      | 9  | 7.2    | 7.6                                 | 6.1    | 6.9   | 5.5    | 6.3   | 5      | 5.6                                  | 4.5    | 4.8                      | 3.8    |
|                     |       | P <sub>t</sub> |                |         |           |         |                        |        |           |        | 49.8      | 59.8   | 36.4                   | 43.7   | 26.2                                | 31.4   | 17.2                   | 20.7   | 11.1   | 13.4   | 5.7                                 | 6.9    | 3.9   | 4.7    | 2.7   | 3.2    | 1.7                                  | 2      | 0.9                      | 1.1    |
|                     |       | NR             |                |         |           |         |                        |        |           |        | 48        | 50     | 44                     | 46     | 41                                  | 43     | 37                     | 39     | 33   | 35     | 26                                  | 28     | 23  | 25     | 19  | 21     | 15                                   | 17     | 8                        | 10     |
| 950                 | 263.9 | V <sub>k</sub> |                |         |           |         |                        |        |           |        | 11.8      | 11.8   | 10.1                   | 10.1   | 8.5                                 | 8.5    | 6.9                    | 6.9    | 5.6  | 5.6    | 4                                   | 4      | 3.3   | 3.3    | 2.7   | 2.7    | 2.2                                  | 2.2    | 1.6                      | 1.6    |
|                     |       | X              |                |         |           |         |                        |        |           |        | 13.8      | 11.1   | 12.8                   | 10.2   | 11.8                                | 9.4    | 10.6                   | 8.5    | 9.5  | 7.6    | 8                                   | 6.4    | 7.3   | 5.8    | 6.6   | 5.3    | 5.9                                  | 4.8    | 5.1                      | 4      |
|                     |       | P <sub>t</sub> |                |         |           |         |                        |        |           |        | 55.5      | 66.6   | 40.6                   | 48.7   | 29.2                                | 35     | 19.2                   | 23     | 12.4   | 14.9   | 6.4                                 | 7.7    | 4.3   | 5.2    | 3   | 3.6    | 1.9                                  | 2.3    | 1                        | 1.2    |
|                     |       | NR             |                |         |           |         |                        |        |           |        | 49        | 51     | 46                     | 48     | 43                                  | 45     | 38                     | 40     | 34   | 36     | 28                                  | 30     | 24  | 26     | 20  | 22     | 16                                   | 18     | 10                       | 12     |
| 1000                | 277.8 | V <sub>k</sub> |                |         |           |         |                        |        |           |        | 10.6      | 10.6   | 9                      | 9      | 7.3                                 | 7.3    | 5.9                    | 5.9    | 4.2  | 4.2    | 3.5                                 | 3.5    | 2.9   | 2.9    | 2.3   | 2.3    | 1.7                                  | 1.7    |                          |        |
|                     |       | X              |                |         |           |         |                        |        |           |        | 13.4      | 10.8   | 12.4                   | 9.9    | 11.2                                | 8.9    | 10                     | 8      | 8.5  | 6.8    | 7.7                                 | 6.2    | 7   | 5.6    | 6.3   | 5      | 5.3                                  | 4.3    |                          |        |
|                     |       | P <sub>t</sub> |                |         |           |         |                        |        |           |        | 45        | 54     | 32.3                   | 38.8   | 21.3                                | 25.5   | 13.7                   | 16.5   | 7.1  | 8.5    | 4.8                                 | 5.8    | 3.3   | 3.9    | 2.1   | 2.5    | 1.1                                  | 1.3    |                          |        |
|                     |       | NR             |                |         |           |         |                        |        |           |        | 47        | 49     | 44                     | 46     | 40                                  | 42     | 35                     | 37     | 29   | 31     | 25                                  | 27     | 21  | 23     | 17  | 19     | 11                                   | 13     |                          |        |
| 1100                | 305.6 | V <sub>k</sub> |                |         |           |         |                        |        |           |        | 11.7      | 11.7   | 9.9                    | 9.9    | 8                                   | 8      | 6.4                    | 6.4    | 4.6  | 4.6    | 3.8                                 | 3.8    | 3.2   | 3.2    | 2.5   | 2.5    | 1.8                                  | 1.8    |                          |        |
|                     |       | X              |                |         |           |         |                        |        |           |        | 14.8      | 11.8   | 13.6                   | 10.9   | 12.3                                | 9.8    | 11                     | 8.8    | 9.3  | 7.5    | 8.5                                 | 6.8    | 7.7   | 6.2    | 6.9   | 5.5    | 5.9                                  | 4.7    |                          |        |
|                     |       | P <sub>t</sub> |                |         |           |         |                        |        |           |        | 54.4      | 65.3   | 39.1                   | 46.9   | 25.7                                | 30.9   | 16.6                   | 19.9   | 8.6  | 10.3   | 5.8                                 | 7      | 4   | 4.8    | 2.6   | 3.1    | 1.3                                  | 1.6    |                          |        |
|                     |       | NR             |                |         |           |         |                        |        |           |        | 49        | 51     | 46                     | 48     | 42                                  | 44     | 38                     | 40     | 31   | 33     | 28                                  | 30     | 24  | 26     | 19  | 21     | 13                                   | 15     |                          |        |

**Quick Selection Table**

| Flow rate           |       | Dim            | 200 x 100      |         | 250 x 100 |         | 300 x 100<br>200 x 150 |        | 250 x 150 |        | 300 x 150 |        | 350 x 150<br>250 x 200 |        | 600 x 100<br>400 x 150<br>300 x 200 |        | 500 x 150<br>350 x 200 |        | 600 x 150<br>450 x 200<br>350 x 250<br>300 x 300 |        | 600 x 200<br>500 x 250<br>400 x 300 |        | 1000 x 150<br>750 x 200<br>600 x 250<br>500 x 300 |        | 1200 x 150<br>900 x 200<br>750 x 250<br>600 x 300 |        | 1100 x 200<br>900 x 250<br>750 x 300 |        | 1200 x 250<br>1000 x 300 |        |     |     |  |
|---------------------|-------|----------------|----------------|---------|-----------|---------|------------------------|--------|-----------|--------|-----------|--------|------------------------|--------|-------------------------------------|--------|------------------------|--------|--|--------|-------------------------------------|--------|---|--------|---|--------|--------------------------------------|--------|--------------------------|--------|-----|-----|--|
|                     |       |                | A <sub>k</sub> | 0.00098 |           | 0.00125 |                        | 0.0148 |           | 0.0183 |           | 0.0224 |                        | 0.0262 |                                     | 0.0309 |                        | 0.0381 |  | 0.0474 |                                     | 0.0660 |   | 0.0801 |   | 0.0970 |                                      | 0.1210 |                          | 0.1670 |     |     |  |
| (m <sup>3</sup> /h) | (l/s) | Ø              | 0°             | 30°     | 0°        | 30°     | 0°                     | 30°    | 0°        | 30°    | 0°        | 30°    | 0°                     | 30°    | 0°                                  | 30°    | 0°                     | 30°    | 0°   | 30°    | 0°                                  | 30°    | 0°  | 30°    | 0°  | 30°    | 0°                                   | 30°    | 0°                       | 30°    |     |     |  |
| 1200                | 333.3 | V <sub>k</sub> |                |         |           |         |                        |        |           |        |           |        |                        |        | 10.8                                | 10.8   | 8.7                    | 8.7    | 7  | 7      | 5.1                                 | 5.1    | 4.2   | 4.2    | 3.4   | 3.4    | 2.8                                  | 2.8    | 2                        | 2      |     |     |  |
|                     |       | X              |                |         |           |         |                        |        |           |        |           |        |                        |        |                                     | 14.9   | 11.9                   | 13.4   | 10.7   | 12     | 9.6                                 | 10.2   | 8.1   | 9.2    | 7.4   | 8.4    | 6.7                                  | 7.5    | 6                        | 6.4    | 5.1 |     |  |
|                     |       | P <sub>t</sub> |                |         |           |         |                        |        |           |        |           |        |                        |        |                                     |        | 46.5                   | 55.9   | 30.6   | 36.7   | 19.8                                | 23.7   | 10.2  | 12.2   | 6.9   | 8.3    | 4.7                                  | 4.7    | 3                        | 3.6    | 1.6 | 1.9 |  |
|                     |       | NR             |                |         |           |         |                        |        |           |        |           |        |                        |        |                                     |        | 48                     | 50     | 44   | 46     | 40                                  | 42     | 33  | 35     | 30  | 32     | 26                                   | 28     | 22                       | 24     | 15  | 17  |  |
| 1300                | 361.1 | V <sub>k</sub> |                |         |           |         |                        |        |           |        |           |        |                        |        | 11.7                                | 11.7   | 9.5                    | 9.5    | 7.6  | 7.6    | 5.5                                 | 5.5    | 4.5   | 4.5    | 3.7   | 3.7    | 3                                    | 3      | 2.2                      | 2.2    |     |     |  |
|                     |       | X              |                |         |           |         |                        |        |           |        |           |        |                        |        |                                     | 16.1   | 12.9                   | 14.5   | 11.6   | 13     | 10.4                                | 11     | 8.8   | 10     | 8   | 9.1    | 7.3                                  | 8.1    | 6.5                      | 6.9    | 5.5 |     |  |
|                     |       | P <sub>t</sub> |                |         |           |         |                        |        |           |        |           |        |                        |        |                                     |        | 54.6                   | 65.6   | 35.9   | 43.1   | 23.2                                | 27.9   | 12  | 14.4   | 8.1   | 9.8    | 5.5                                  | 6.7    | 3.6                      | 4.3    | 1.9 | 2.2 |  |
|                     |       | NR             |                |         |           |         |                        |        |           |        |           |        |                        |        |                                     |        | 50                     | 52     | 46   | 48     | 42                                  | 44     | 35  | 37     | 32  | 34     | 28                                   | 30     | 24                       | 26     | 17  | 19  |  |
| 1400                | 388.9 | V <sub>k</sub> |                |         |           |         |                        |        |           |        |           |        |                        |        | 12.6                                | 12.6   | 10.2                   | 10.2   | 8.2  | 8.2    | 5.9                                 | 5.9    | 4.9   | 4.9    | 4   | 4      | 3.2                                  | 3.2    | 2.3                      | 2.3    |     |     |  |
|                     |       | X              |                |         |           |         |                        |        |           |        |           |        |                        |        |                                     | 17.3   | 13.9                   | 15.6   | 12.5   | 14     | 11.2                                | 11.9   | 9.5   | 10.8   | 8.6   | 9.8    | 7.8                                  | 8.8    | 7                        | 7.5    | 6   |     |  |
|                     |       | P <sub>t</sub> |                |         |           |         |                        |        |           |        |           |        |                        |        |                                     |        | 63.4                   | 76     | 41.7   | 50     | 26.9                                | 32.2   | 13.9  | 16.7   | 9.4   | 11.3   | 6.4                                  | 7.7    | 4.1                      | 5      | 2.2 | 2.6 |  |
|                     |       | NR             |                |         |           |         |                        |        |           |        |           |        |                        |        |                                     |        | 52                     | 54     | 48   | 50     | 44                                  | 46     | 37  | 39     | 33  | 35     | 30                                   | 32     | 25                       | 27     | 19  | 21  |  |
| 1500                | 416.7 | V <sub>k</sub> |                |         |           |         |                        |        |           |        |           |        |                        |        |                                     |        |                        |        |  |        |                                     |        |   |        |   |        |                                      |        |                          |        |     |     |  |
|                     |       | X              |                |         |           |         |                        |        |           |        |           |        |                        |        |                                     |        |                        |        |  |        |                                     |        |   |        |   |        |                                      |        |                          |        |     |     |  |
|                     |       | P <sub>t</sub> |                |         |           |         |                        |        |           |        |           |        |                        |        |                                     |        |                        |        |  |        |                                     |        |   |        |   |        |                                      |        |                          |        |     |     |  |
|                     |       | NR             |                |         |           |         |                        |        |           |        |           |        |                        |        |                                     |        |                        |        |  |        |                                     |        |   |        |   |        |                                      |        |                          |        |     |     |  |
| 1600                | 444.4 | V <sub>k</sub> |                |         |           |         |                        |        |           |        |           |        |                        |        |                                     |        |                        |        |  |        |                                     |        |   |        |   |        |                                      |        |                          |        |     |     |  |
|                     |       | X              |                |         |           |         |                        |        |           |        |           |        |                        |        |                                     |        |                        |        |  |        |                                     |        |   |        |   |        |                                      |        |                          |        |     |     |  |
|                     |       | P <sub>t</sub> |                |         |           |         |                        |        |           |        |           |        |                        |        |                                     |        |                        |        |  |        |                                     |        |   |        |   |        |                                      |        |                          |        |     |     |  |
|                     |       | NR             |                |         |           |         |                        |        |           |        |           |        |                        |        |                                     |        |                        |        |  |        |                                     |        |   |        |   |        |                                      |        |                          |        |     |     |  |
| 1700                | 472.2 | V <sub>k</sub> |                |         |           |         |                        |        |           |        |           |        |                        |        |                                     |        |                        |        |  |        |                                     |        |   |        |   |        |                                      |        |                          |        |     |     |  |
|                     |       | X              |                |         |           |         |                        |        |           |        |           |        |                        |        |                                     |        |                        |        |  |        |                                     |        |   |        |   |        |                                      |        |                          |        |     |     |  |
|                     |       | P <sub>t</sub> |                |         |           |         |                        |        |           |        |           |        |                        |        |                                     |        |                        |        |  |        |                                     |        |   |        |   |        |                                      |        |                          |        |     |     |  |
|                     |       | NR             |                |         |           |         |                        |        |           |        |           |        |                        |        |                                     |        |                        |        |  |        |                                     |        |   |        |   |        |                                      |        |                          |        |     |     |  |
| 1800                | 500.0 | V <sub>k</sub> |                |         |           |         |                        |        |           |        |           |        |                        |        |                                     |        |                        |        |  |        |                                     |        |   |        |   |        |                                      |        |                          |        |     |     |  |
|                     |       | X              |                |         |           |         |                        |        |           |        |           |        |                        |        |                                     |        |                        |        |  |        |                                     |        |   |        |   |        |                                      |        |                          |        |     |     |  |
|                     |       | P <sub>t</sub> |                |         |           |         |                        |        |           |        |           |        |                        |        |                                     |        |                        |        |  |        |                                     |        |   |        |   |        |                                      |        |                          |        |     |     |  |
|                     |       | NR             |                |         |           |         |                        |        |           |        |           |        |                        |        |                                     |        |                        |        |  |        |                                     |        |   |        |   |        |                                      |        |                          |        |     |     |  |
| 1900                | 527.8 | V <sub>k</sub> |                |         |           |         |                        |        |           |        |           |        |                        |        |                                     |        |                        |        |  |        |                                     |        |   |        |   |        |                                      |        |                          |        |     |     |  |
|                     |       | X              |                |         |           |         |                        |        |           |        |           |        |                        |        |                                     |        |                        |        |  |        |                                     |        |   |        |   |        |                                      |        |                          |        |     |     |  |
|                     |       | P <sub>t</sub> |                |         |           |         |                        |        |           |        |           |        |                        |        |                                     |        |                        |        |  |        |                                     |        |   |        |   |        |                                      |        |                          |        |     |     |  |
|                     |       | NR             |                |         |           |         |                        |        |           |        |           |        |                        |        |                                     |        |                        |        |  |        |                                     |        |   |        |   |        |                                      |        |                          |        |     |     |  |
| 2000                | 555.6 | V <sub>k</sub> |                |         |           |         |                        |        |           |        |           |        |                        |        |                                     |        |                        |        |  |        |                                     |        |   |        |   |        |                                      |        |                          |        |     |     |  |
|                     |       | X              |                |         |           |         |                        |        |           |        |           |        |                        |        |                                     |        |                        |        |  |        |                                     |        |   |        |   |        |                                      |        |                          |        |     |     |  |
|                     |       | P <sub>t</sub> |                |         |           |         |                        |        |           |        |           |        |                        |        |                                     |        |                        |        |  |        |                                     |        |   |        |   |        |                                      |        |                          |        |     |     |  |
|                     |       | NR             |                |         |           |         |                        |        |           |        |           |        |                        |        |                                     |        |                        |        |  |        |                                     |        |   |        |   |        |                                      |        |                          |        |     |     |  |
| 2100                | 583.3 | V <sub>k</sub> |                |         |           |         |                        |        |           |        |           |        |                        |        |                                     |        |                        |        |  |        |                                     |        |   |        |   |        |                                      |        |                          |        |     |     |  |
|                     |       | X              |                |         |           |         |                        |        |           |        |           |        |                        |        |                                     |        |                        |        |  |        |                                     |        |   |        |   |        |                                      |        |                          |        |     |     |  |
|                     |       | P <sub>t</sub> |                |         |           |         |                        |        |           |        |           |        |                        |        |                                     |        |                        |        |  |        |                                     |        |   |        |   |        |                                      |        |                          |        |     |     |  |
|                     |       | NR             |                |         |           |         |                        |        |           |        |           |        |                        |        |                                     |        |                        |        |  |        |                                     |        |   |        |   |        |                                      |        |                          |        |     |     |  |

## Quick Selection Table

| Flow rate           |        | Dim            | 200 x 100      |         | 250 x 100 |         | 300 x 100<br>200 x 150 |        | 250 x 150 |        | 300 x 150 |        | 350 x 150<br>250 x 200 |        | 600 x 100<br>400 x 150<br>300 x 200 |        | 500 x 150<br>350 x 200 |        | 600 x 150<br>450 x 200<br>350 x 250<br>300 x 300 |        | 600 x 200<br>500 x 250<br>400 x 300 |        | 1000 x 150<br>750 x 200<br>600 x 250<br>500 x 300 |        | 1200 x 150<br>900 x 200<br>750 x 250<br>600 x 300 |        | 1100 x 200<br>900 x 250<br>750 x 300 |        | 1200 x 250<br>1000 x 300 |        |      |
|---------------------|--------|----------------|----------------|---------|-----------|---------|------------------------|--------|-----------|--------|-----------|--------|------------------------|--------|-------------------------------------|--------|------------------------|--------|--|--------|-------------------------------------|--------|---|--------|---|--------|--------------------------------------|--------|--------------------------|--------|------|
|                     |        |                | A <sub>k</sub> | 0.00098 |           | 0.00125 |                        | 0.0148 |           | 0.0183 |           | 0.0224 |                        | 0.0262 |                                     | 0.0309 |                        | 0.0381 |  | 0.0474 |                                     | 0.0660 |   | 0.0801 |   | 0.0970 |                                      | 0.1210 |                          | 0.1670 |      |
| (m <sup>3</sup> /h) | (l/s)  | Ø              | 0°             | 30°     | 0°        | 30°     | 0°                     | 30°    | 0°        | 30°    | 0°        | 30°    | 0°                     | 30°    | 0°                                  | 30°    | 0°                     | 30°    | 0°   | 30°    | 0°                                  | 30°    | 0°  | 30°    | 0°  | 30°    | 0°                                   | 30°    | 0°                       | 30°    |      |
| 2200                | 611.1  | V <sub>k</sub> |                |         |           |         |                        |        |           |        |           |        |                        |        |                                     |        |                        |        |  |        | 9.3                                 | 9.3    | 7.6   | 7.6    | 6.3   | 6.3    | 5.1                                  | 5.1    | 3.7                      | 3.7    |      |
|                     |        | X              |                |         |           |         |                        |        |           |        |           |        |                        |        |                                     |        |                        |        |  |        |                                     | 18.6   | 14.9  | 16.9   | 13.5  | 15.4   | 12.3                                 | 13.8   | 11                       | 11.7   | 9.4  |
|                     |        | P <sub>t</sub> |                |         |           |         |                        |        |           |        |           |        |                        |        |                                     |        |                        |        |  |        |                                     | 34.3   | 41.2  | 23.3   | 27.9  | 15.9   | 19.1                                 | 10.2   | 12.2                     | 5.4    | 6.4  |
|                     |        | NR             |                |         |           |         |                        |        |           |        |           |        |                        |        |                                     |        |                        |        |  |        |                                     | 48     | 50  | 44     | 46  | 41     | 43                                   | 36     | 38                       | 30     | 32   |
| 2400                | 666.7  | V <sub>k</sub> |                |         |           |         |                        |        |           |        |           |        |                        |        |                                     |        |                        |        |  |        | 10.1                                | 10.1   | 8.3   | 8.3    | 6.9   | 6.9    | 5.5                                  | 5.5    | 4                        | 4      |      |
|                     |        | X              |                |         |           |         |                        |        |           |        |           |        |                        |        |                                     |        |                        |        |  |        | 20.3                                | 16.3   | 18.5  | 14.8   | 16.8  | 13.4   | 15                                   | 12     | 12.8                     | 10.2   |      |
|                     |        | P <sub>t</sub> |                |         |           |         |                        |        |           |        |           |        |                        |        |                                     |        |                        |        |  |        | 40.8                                | 49     | 27.7  | 33.3   | 18.9  | 22.7   | 12.1                                 | 14.6   | 6.4                      | 7.6    |      |
|                     |        | NR             |                |         |           |         |                        |        |           |        |           |        |                        |        |                                     |        |                        |        |  |        | 50                                  | 52     | 46  | 48     | 43  | 45     | 38                                   | 40     | 32                       | 34     |      |
| 2600                | 722.2  | V <sub>k</sub> |                |         |           |         |                        |        |           |        |           |        |                        |        |                                     |        |                        |        |  |        | 10.9                                | 10.9   | 9   | 9      | 7.4   | 7.4    | 6                                    | 6      | 4.3                      | 4.3    |      |
|                     |        | X              |                |         |           |         |                        |        |           |        |           |        |                        |        |                                     |        |                        |        |  |        | 22                                  | 17.6   | 20  | 16     | 18.2  | 14.5   | 16.3                                 | 13     | 13.8                     | 11.1   |      |
|                     |        | P <sub>t</sub> |                |         |           |         |                        |        |           |        |           |        |                        |        |                                     |        |                        |        |  |        | 47.9                                | 57.5   | 32.5  | 39     | 22.2  | 26.6   | 14.3                                 | 17.1   | 7.5                      | 9      |      |
|                     |        | NR             |                |         |           |         |                        |        |           |        |           |        |                        |        |                                     |        |                        |        |  |        | 52                                  | 54     | 48  | 50     | 45  | 47     | 40                                   | 42     | 34                       | 36     |      |
| 2800                | 777.8  | V <sub>k</sub> |                |         |           |         |                        |        |           |        |           |        |                        |        |                                     |        |                        |        |  |        |                                     |        | 9.7   | 9.7    | 8   | 8      | 6.4                                  | 6.4    | 4.7                      | 4.7    |      |
|                     |        | X              |                |         |           |         |                        |        |           |        |           |        |                        |        |                                     |        |                        |        |  |        |                                     |        | 21.5  | 17.2   | 19.6  | 15.7   | 17.5                                 | 14     | 14.9                     | 11.9   |      |
|                     |        | P <sub>t</sub> |                |         |           |         |                        |        |           |        |           |        |                        |        |                                     |        |                        |        |  |        |                                     |        |   | 37.7   | 45.3  | 25.7   | 30.9                                 | 16.5   | 19.8                     | 8.7    | 10.4 |
|                     |        | NR             |                |         |           |         |                        |        |           |        |           |        |                        |        |                                     |        |                        |        |  |        |                                     |        |   | 50     | 52  | 46     | 48                                   | 42     | 44                       | 36     | 38   |
| 3000                | 833.3  | V <sub>k</sub> |                |         |           |         |                        |        |           |        |           |        |                        |        |                                     |        |                        |        |  |        |                                     |        | 10.4  | 10.4   | 8.6   | 8.6    | 6.9                                  | 6.9    | 5                        | 5      |      |
|                     |        | X              |                |         |           |         |                        |        |           |        |           |        |                        |        |                                     |        |                        |        |  |        |                                     |        | 23.1  | 18.5   | 21  | 16.8   | 18.8                                 | 15     | 16                       | 12.8   |      |
|                     |        | P <sub>t</sub> |                |         |           |         |                        |        |           |        |           |        |                        |        |                                     |        |                        |        |  |        |                                     |        |   | 43.3   | 52  | 29.5   | 35.4                                 | 19     | 22.8                     | 10     | 12   |
|                     |        | NR             |                |         |           |         |                        |        |           |        |           |        |                        |        |                                     |        |                        |        |  |        |                                     |        |   | 52     | 54  | 48     | 50                                   | 44     | 46                       | 38     | 40   |
| 3200                | 888.9  | V <sub>k</sub> |                |         |           |         |                        |        |           |        |           |        |                        |        |                                     |        |                        |        |  |        |                                     |        |   | 9.2    | 9.2   | 7.3    | 7.3                                  | 5.3    | 5.3                      |        |      |
|                     |        | X              |                |         |           |         |                        |        |           |        |           |        |                        |        |                                     |        |                        |        |  |        |                                     |        |   | 22.4   | 17.9  | 20     | 16                                   | 17     | 13.6                     |        |      |
|                     |        | P <sub>t</sub> |                |         |           |         |                        |        |           |        |           |        |                        |        |                                     |        |                        |        |  |        |                                     |        |   |        | 33.6  | 40.3   | 21.6                                 | 25.9   | 11.3                     | 13.6   |      |
|                     |        | NR             |                |         |           |         |                        |        |           |        |           |        |                        |        |                                     |        |                        |        |  |        |                                     |        |   |        | 50  | 52     | 45                                   | 47     | 39                       | 41     |      |
| 3500                | 972.2  | V <sub>k</sub> |                |         |           |         |                        |        |           |        |           |        |                        |        |                                     |        |                        |        |  |        |                                     |        |   | 10     | 10  | 8      | 8                                    | 5.8    | 5.8                      |        |      |
|                     |        | X              |                |         |           |         |                        |        |           |        |           |        |                        |        |                                     |        |                        |        |  |        |                                     |        |   | 24.5   | 19.6  | 21.9   | 17.5                                 | 18.6   | 14.9                     |        |      |
|                     |        | P <sub>t</sub> |                |         |           |         |                        |        |           |        |           |        |                        |        |                                     |        |                        |        |  |        |                                     |        |   |        | 40.2  | 48.2   | 25.8                                 | 31     | 13.6                     | 16.3   |      |
|                     |        | NR             |                |         |           |         |                        |        |           |        |           |        |                        |        |                                     |        |                        |        |  |        |                                     |        |   |        | 52  | 54     | 48                                   | 50     | 41                       | 43     |      |
| 3800                | 1056.6 | V <sub>k</sub> |                |         |           |         |                        |        |           |        |           |        |                        |        |                                     |        |                        |        |  |        |                                     |        |   | 10.9   | 10.9  | 8.7    | 8.7                                  | 6.3    | 6.3                      |        |      |
|                     |        | X              |                |         |           |         |                        |        |           |        |           |        |                        |        |                                     |        |                        |        |  |        |                                     |        |   | 26.6   | 21.2  | 23.8   | 19                                   | 20.2   | 16.2                     |        |      |
|                     |        | P <sub>t</sub> |                |         |           |         |                        |        |           |        |           |        |                        |        |                                     |        |                        |        |  |        |                                     |        |   |        | 47.4  | 56.8   | 30.4                                 | 36.5   | 16                       | 19.2   |      |
|                     |        | NR             |                |         |           |         |                        |        |           |        |           |        |                        |        |                                     |        |                        |        |  |        |                                     |        |   |        | 54  | 56     | 50                                   | 52     | 43                       | 45     |      |
| 4100                | 1138.9 | V <sub>k</sub> |                |         |           |         |                        |        |           |        |           |        |                        |        |                                     |        |                        |        |  |        |                                     |        |   |        |   | 9.4    | 9.4                                  | 6.8    | 6.8                      |        |      |
|                     |        | X              |                |         |           |         |                        |        |           |        |           |        |                        |        |                                     |        |                        |        |  |        |                                     |        |   |        |   | 25.7   | 20.5                                 | 21.8   | 17.5                     |        |      |
|                     |        | P <sub>t</sub> |                |         |           |         |                        |        |           |        |           |        |                        |        |                                     |        |                        |        |  |        |                                     |        |   |        |   |        | 35.4                                 | 42.5   | 18.6                     | 22.3   |      |
|                     |        | NR             |                |         |           |         |                        |        |           |        |           |        |                        |        |                                     |        |                        |        |  |        |                                     |        |   |        |   |        | 51                                   | 53     | 45                       | 47     |      |
| 4500                | 1250.0 | V <sub>k</sub> |                |         |           |         |                        |        |           |        |           |        |                        |        |                                     |        |                        |        |  |        |                                     |        |   |        |   |        | 10.3                                 | 10.3   | 7.5                      | 7.5    |      |
|                     |        | X              |                |         |           |         |                        |        |           |        |           |        |                        |        |                                     |        |                        |        |  |        |                                     |        |   |        |   |        | 28.2                                 | 22.5   | 24                       | 19.2   |      |
|                     |        | P <sub>t</sub> |                |         |           |         |                        |        |           |        |           |        |                        |        |                                     |        |                        |        |  |        |                                     |        |   |        |   |        |                                      | 42.7   | 51.2                     | 22.4   | 26.9 |
|                     |        | NR             |                |         |           |         |                        |        |           |        |           |        |                        |        |                                     |        |                        |        |  |        |                                     |        |   |        |   |        |                                      | 54     | 56                       | 47     | 49   |

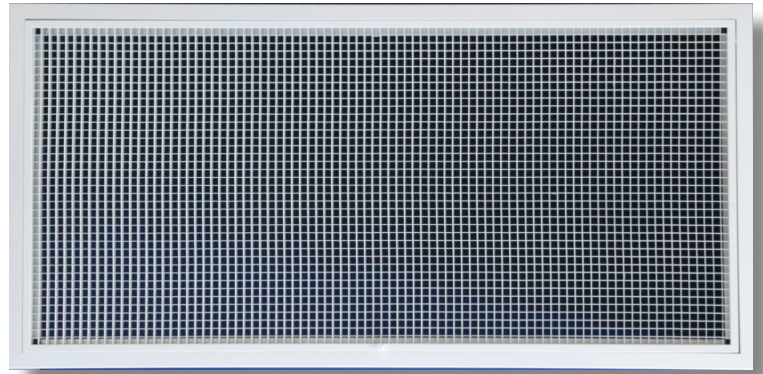
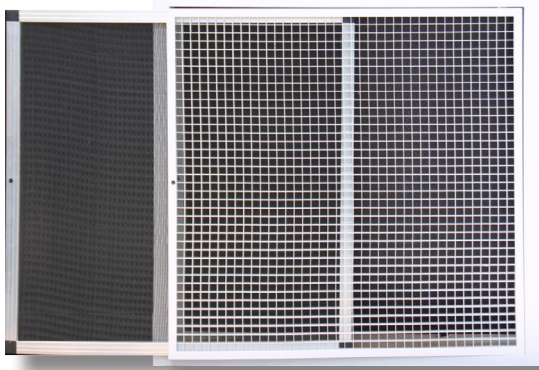

## Hinged Eggcrate Grille with Removable Filter

### General Information:

Ideal for exhaust and return air applications. The Eggcrate Grille is the most popular and economical for exhaust and return air applications. The Loose Core Eggcrate grille allows the installer to simply push the core up and easily fix the frame into position and drop the core back into the outer frame. Also available with 35 degree Eggcrate Core.

### Features:

- Capable of transferring or returning high air volumes at minimum pressure requirements
- Made of extruded aluminium
- Rigid, heavy gauge extruded frames with reinforced mitered and welded corners
- Surface mounting or concealed mounting
- Sizes manufactured on request
- Filter: Non woven fabrics or nitrilon

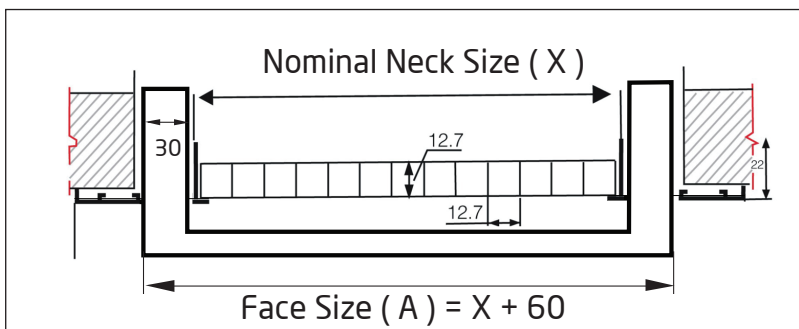

| Nominal Neck Metric ( X ) | Face Size ( A ) |
|---------------------------|-----------------|
| 150 x 150 mm              | 200 x 200 mm    |
| 200 x 200 mm              | 250 x 250 mm    |
| 300 x 300 mm              | 350 x 350 mm    |
| 545 x 545 mm              | 595 x 595 mm    |
| 1145 x 545 mm             | 1195 x 595 mm   |

\* Grilles are powder coated white as standard

\* The first number is for horizontal dimension and the second number is for vertical dimension

## Quick Selection Table

| Nom. Neck (mm) | Equivalent Size (mm) | Core Area (m <sup>2</sup> ) | V <sub>k</sub> | 1.5 | 2.0 | 2.5 | 3.0 | 3.5  | 4.0  | 4.5  | 5.0  | 6.0  |
|----------------|----------------------|-----------------------------|----------------|-----|-----|-----|-----|------|------|------|------|------|
|                |                      |                             | P <sub>t</sub> | 1   | 3   | 4   | 6   | 8    | 10   | 13   | 16   | 23   |
| 150 x 150      | 225 x 100            | 0.020                       | Q              | 30  | 41  | 51  | 61  | 71   | 81   | 91   | 101  | 122  |
|                |                      |                             | NR             | <15 | <15 | 15  | 19  | 23   | 26   | 29   | 32   | 37   |
| 200 x 150      | 250 x 125            | 0.027                       | Q              | 41  | 54  | 68  | 81  | 95   | 108  | 122  | 135  | 162  |
|                | 300 x 100            |                             | NR             | <15 | <15 | 16  | 19  | 23   | 26   | 29   | 32   | 37   |
| 250 x 150      | 300 x 125            | 0.034                       | Q              | 54  | 72  | 90  | 108 | 126  | 144  | 162  | 180  | 216  |
|                | 400 x 100            |                             | NR             | <15 | <15 | 16  | 19  | 23   | 26   | 30   | 33   | 38   |
| 200 x 200      | 350 x 125            | 0.036                       | Q              | 61  | 81  | 101 | 122 | 142  | 162  | 182  | 203  | 243  |
|                |                      |                             | NR             | <15 | <15 | 16  | 19  | 24   | 26   | 30   | 33   | 38   |
| 300 x 150      | 450 x 100            | 0.041                       | Q              | 81  | 108 | 135 | 162 | 189  | 216  | 243  | 270  | 324  |
|                |                      |                             | NR             | <15 | <15 | 16  | 20  | 24   | 27   | 30   | 33   | 38   |
| 300 x 200      | 400 x 150            | 0.054                       | Q              | 84  | 113 | 141 | 169 | 197  | 225  | 253  | 281  | 338  |
|                | 600 x 100            |                             | NR             | <15 | <15 | 16  | 20  | 24   | 27   | 30   | 34   | 39   |
| 250 x 250      | 350 x 175            | 0.056                       | Q              | 91  | 122 | 152 | 182 | 213  | 243  | 273  | 304  | 365  |
|                | 650 x 100            |                             | NR             | <15 | <15 | 16  | 20  | 25   | 27   | 30   | 34   | 39   |
| 450 x 150      | 350 x 200            | 0.061                       | Q              | 101 | 135 | 169 | 203 | 236  | 270  | 304  | 338  | 405  |
|                | 750 x 100            |                             | NR             | <15 | <15 | 16  | 20  | 25   | 27   | 31   | 35   | 39   |
|                | 700 x 100            |                             |                |     |     |     |     |      |      |      |      |      |
| 300 x 250      | 400 x 200            | 0.068                       | Q              | 122 | 162 | 203 | 243 | 284  | 324  | 365  | 405  | 486  |
|                | 500 x 200            |                             | NR             | <15 | <15 | 16  | 21  | 25   | 28   | 31   | 35   | 40   |
|                | 600 x 125            |                             |                |     |     |     |     |      |      |      |      |      |
| 300 x 300      | 350 x 250            | 0.081                       | Q              | 165 | 221 | 276 | 331 | 386  | 441  | 496  | 551  | 662  |
|                | 450 x 200            |                             | NR             | <15 | <15 | 17  | 21  | 26   | 28   | 31   | 35   | 40   |
|                | 600 x 150            |                             |                |     |     |     |     |      |      |      |      |      |
| 350 x 350      | 950 x 100            | 0.110                       | Q              | 182 | 243 | 304 | 365 | 425  | 486  | 547  | 608  | 729  |
|                | 400 x 300            |                             | NR             | <15 | <15 | 17  | 21  | 26   | 28   | 31   | 36   | 41   |
|                | 500 x 250            |                             |                |     |     |     |     |      |      |      |      |      |
| 450 x 300      | 600 x 200            | 0.122                       | Q              | 203 | 207 | 338 | 405 | 473  | 540  | 608  | 675  | 810  |
|                | 850 x 150            |                             | NR             | <15 | <15 | 17  | 22  | 26   | 28   | 32   | 36   | 41   |
|                | 400 x 350            |                             |                |     |     |     |     |      |      |      |      |      |
| 600 x 250      | 500 x 300            | 0.135                       | Q              | 216 | 288 | 360 | 432 | 404  | 576  | 648  | 720  | 864  |
|                | 750 x 200            |                             | NR             | <15 | <15 | 17  | 22  | 26   | 29   | 32   | 37   | 42   |
| 400 x 400      | 400 x 350            | 0.144                       | Q              | 243 | 324 | 405 | 486 | 567  | 648  | 729  | 810  | 972  |
|                | 550 x 300            |                             | NR             | <15 | <15 | 17  | 22  | 26   | 29   | 32   | 37   | 42   |
|                | 750 x 200            |                             |                |     |     |     |     |      |      |      |      |      |
| 600 x 300      | 450 x 400            | 0.162                       | Q              | 273 | 365 | 456 | 547 | 638  | 729  | 820  | 911  | 1094 |
|                | 500 x 350            |                             | NR             | <15 | <15 | 17  | 22  | 27   | 29   | 33   | 38   | 43   |
|                | 750 x 250            |                             |                |     |     |     |     |      |      |      |      |      |
| 450 x 450      | 900 x 200            | 0.182                       | Q              | 304 | 405 | 506 | 608 | 709  | 810  | 911  | 1013 | 1215 |
|                | 500 x 400            |                             | NR             | <15 | <15 | 17  | 22  | 27   | 29   | 33   | 38   | 43   |
|                | 600 x 350            |                             |                |     |     |     |     |      |      |      |      |      |
| 750 x 300      | 800 x 250            | 0.203                       | Q              | 380 | 450 | 563 | 675 | 788  | 900  | 1013 | 1125 | 1350 |
|                | 500 x 450            |                             | NR             | <15 | <15 | 17  | 23  | 27   | 30   | 33   | 38   | 44   |
|                | 650 x 350            |                             |                |     |     |     |     |      |      |      |      |      |
| 500 x 500      | 550 x 400            | 0.225                       | Q              | 408 | 545 | 681 | 817 | 953  | 1089 | 1225 | 1361 | 1634 |
|                | 900 x 250            |                             | NR             | <15 | <15 | 17  | 23  | 27   | 30   | 34   | 39   | 44   |
|                | 600 x 450            |                             |                |     |     |     |     |      |      |      |      |      |
| 550 x 550      | 750 x 350            | 0.272                       | Q              | 486 | 648 | 810 | 972 | 1134 | 1296 | 1458 | 1620 | 1944 |
|                | 900 x 300            |                             | NR             | <15 | 15  | 17  | 24  | 28   | 31   | 35   | 39   | 45   |
|                | 600 x 500            |                             |                |     |     |     |     |      |      |      |      |      |

Symbols:

V<sub>k</sub> - Effective velocity in m/s

Q - Flow rate (l/s)

Pressure (P<sub>t</sub>) - All pressures are in Pa (N/m<sup>2</sup>)

NR - Noise level index in dB based on a room absorption and one diffuser

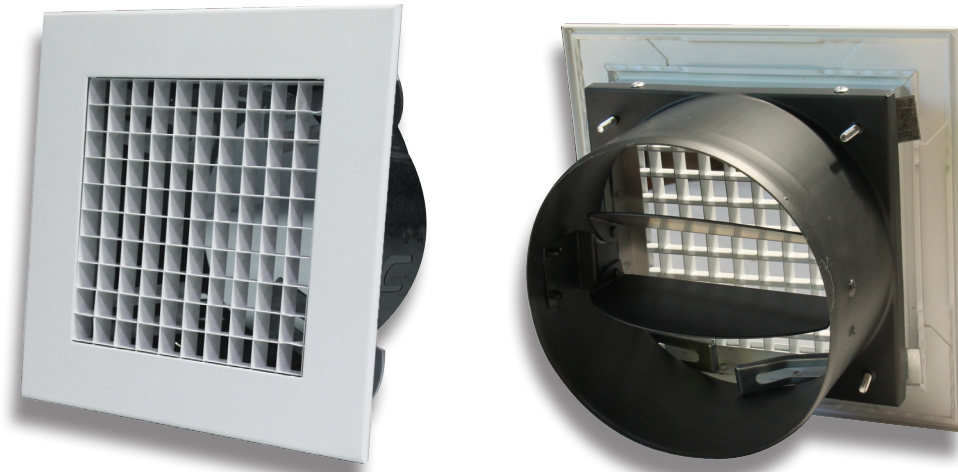

## Eggcrate Grille with Fixing Clip Reducing Neck

### General Information:

Ideal for exhaust and return air applications. The Eggcrate Grille is the most popular and economical for exhaust and return air applications. The Eggcrate Grille with fixing clip reducing neck allows the installer to simply push the core up and easily fix the frame into position and drop the core back into the outer frame.

### Features:

- Capable of transferring or returning high air volumes at minimum pressure requirements
- Made of extruded aluminium
- Rigid, heavy gauge extruded frames with reinforced mitered and welded corners
- Surface mounting or concealed mounting
- Sizes manufactured on request
- Filter: Non woven fabrics or nitrilon

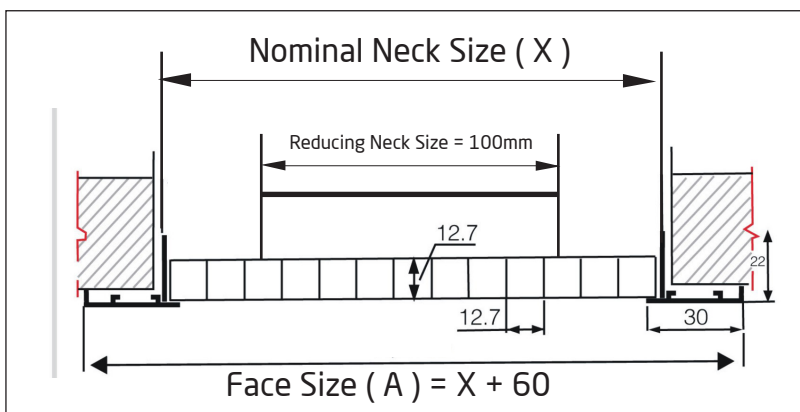

| Nominal Neck Metric ( X ) | Face Size ( A ) |
|---------------------------|-----------------|
| 150 x 150 mm              | 200 x 200 mm    |
| 200 x 200 mm              | 250 x 250 mm    |
| 250 x 250 mm              | 300 x 300 mm    |
| 300 x 300 mm              | 350 x 350 mm    |

\* Grilles are powder coated white as standard

\* The first number is for horizontal dimension and the second number is for vertical dimension

## Quick Selection Table

| Nom. Neck (mm) | Equivalent Size (mm) | Core Area (m <sup>2</sup> ) | V <sub>k</sub> | 1.5 | 2.0 | 2.5 | 3.0 | 3.5  | 4.0  | 4.5  | 5.0  | 6.0  |
|----------------|----------------------|-----------------------------|----------------|-----|-----|-----|-----|------|------|------|------|------|
|                |                      |                             | P <sub>t</sub> | 1   | 3   | 4   | 6   | 8    | 10   | 13   | 16   | 23   |
| 150 x 150      | 225 x 100            | 0.020                       | Q              | 30  | 41  | 51  | 61  | 71   | 81   | 91   | 101  | 122  |
|                |                      |                             | NR             | <15 | <15 | 15  | 19  | 23   | 26   | 29   | 32   | 37   |
| 200 x 150      | 250 x 125            | 0.027                       | Q              | 41  | 54  | 68  | 81  | 95   | 108  | 122  | 135  | 162  |
|                | 300 x 100            |                             | NR             | <15 | <15 | 16  | 19  | 23   | 26   | 29   | 32   | 37   |
| 250 x 150      | 300 x 125            | 0.034                       | Q              | 54  | 72  | 90  | 108 | 126  | 144  | 162  | 180  | 216  |
|                | 400 x 100            |                             | NR             | <15 | <15 | 16  | 19  | 23   | 26   | 30   | 33   | 38   |
| 200 x 200      | 350 x 125            | 0.036                       | Q              | 61  | 81  | 101 | 122 | 142  | 162  | 182  | 203  | 243  |
|                |                      |                             | NR             | <15 | <15 | 16  | 19  | 24   | 26   | 30   | 33   | 38   |
| 300 x 150      | 450 x 100            | 0.041                       | Q              | 81  | 108 | 135 | 162 | 189  | 216  | 243  | 270  | 324  |
|                |                      |                             | NR             | <15 | <15 | 16  | 20  | 24   | 27   | 30   | 33   | 38   |
| 300 x 200      | 400 x 150            | 0.054                       | Q              | 84  | 113 | 141 | 169 | 197  | 225  | 253  | 281  | 338  |
|                | 600 x 100            |                             | NR             | <15 | <15 | 16  | 20  | 24   | 27   | 30   | 34   | 39   |
| 250 x 250      | 350 x 175            | 0.056                       | Q              | 91  | 122 | 152 | 182 | 213  | 243  | 273  | 304  | 365  |
|                | 650 x 100            |                             | NR             | <15 | <15 | 16  | 20  | 25   | 27   | 30   | 34   | 39   |
| 450 x 150      | 350 x 200            | 0.061                       | Q              | 101 | 135 | 169 | 203 | 236  | 270  | 304  | 338  | 405  |
|                | 750 x 100            |                             | NR             | <15 | <15 | 16  | 20  | 25   | 27   | 31   | 35   | 39   |
|                | 700 x 100            |                             |                |     |     |     |     |      |      |      |      |      |
| 300 x 250      | 400 x 200            | 0.068                       | Q              | 122 | 162 | 203 | 243 | 284  | 324  | 365  | 405  | 486  |
|                | 500 x 200            |                             | NR             | <15 | <15 | 16  | 21  | 25   | 28   | 31   | 35   | 40   |
|                | 600 x 125            |                             |                |     |     |     |     |      |      |      |      |      |
| 300 x 300      | 350 x 250            | 0.081                       | Q              | 165 | 221 | 276 | 331 | 386  | 441  | 496  | 551  | 662  |
|                | 450 x 200            |                             | NR             | <15 | <15 | 17  | 21  | 26   | 28   | 31   | 35   | 40   |
|                | 600 x 150            |                             |                |     |     |     |     |      |      |      |      |      |
| 350 x 350      | 950 x 100            | 0.110                       | Q              | 182 | 243 | 304 | 365 | 425  | 486  | 547  | 608  | 729  |
|                | 400 x 300            |                             | NR             | <15 | <15 | 17  | 21  | 26   | 28   | 31   | 36   | 41   |
|                | 500 x 250            |                             |                |     |     |     |     |      |      |      |      |      |
| 450 x 300      | 600 x 200            | 0.122                       | Q              | 203 | 207 | 338 | 405 | 473  | 540  | 608  | 675  | 810  |
|                | 850 x 150            |                             | NR             | <15 | <15 | 17  | 22  | 26   | 28   | 32   | 36   | 41   |
|                | 400 x 350            |                             |                |     |     |     |     |      |      |      |      |      |
| 600 x 250      | 550 x 250            | 0.135                       | Q              | 216 | 288 | 360 | 432 | 404  | 576  | 648  | 720  | 864  |
|                | 750 x 200            |                             | NR             | <15 | <15 | 17  | 22  | 26   | 29   | 32   | 37   | 42   |
| 400 x 400      | 500 x 300            | 0.144                       | Q              | 243 | 324 | 405 | 486 | 567  | 648  | 729  | 810  | 972  |
|                | 750 x 200            |                             | NR             | <15 | <15 | 17  | 22  | 26   | 29   | 32   | 37   | 42   |
|                | -                    |                             |                |     |     |     |     |      |      |      |      |      |
| 600 x 300      | 400 x 350            | 0.162                       | Q              | 273 | 365 | 456 | 547 | 638  | 729  | 820  | 911  | 1094 |
|                | 500 x 350            |                             | NR             | <15 | <15 | 17  | 22  | 27   | 29   | 33   | 38   | 43   |
|                | 750 x 2509           |                             |                |     |     |     |     |      |      |      |      |      |
| 450 x 450      | 900 x 200            | 0.182                       | Q              | 304 | 405 | 506 | 608 | 709  | 810  | 911  | 1013 | 1215 |
|                | 500 x 400            |                             | NR             | <15 | <15 | 17  | 22  | 27   | 29   | 33   | 38   | 43   |
|                | 600 x 350            |                             |                |     |     |     |     |      |      |      |      |      |
| 750 x 300      | 700 x 300            | 0.203                       | Q              | 380 | 450 | 563 | 675 | 788  | 900  | 1013 | 1125 | 1350 |
|                | 800 x 250            |                             | NR             | <15 | <15 | 17  | 23  | 27   | 30   | 33   | 38   | 44   |
|                | 550 x 400            |                             |                |     |     |     |     |      |      |      |      |      |
| 500 x 500      | 900 x 250            | 0.225                       | Q              | 408 | 545 | 681 | 817 | 953  | 1089 | 1225 | 1361 | 1634 |
|                | 600 x 450            |                             | NR             | <15 | <15 | 17  | 23  | 27   | 30   | 34   | 39   | 44   |
|                | 650 x 400            |                             |                |     |     |     |     |      |      |      |      |      |
| 550 x 550      | 750 x 350            | 0.272                       | Q              | 486 | 648 | 810 | 972 | 1134 | 1296 | 1458 | 1620 | 1944 |
|                | 900 x 300            |                             | NR             | <15 | 15  | 17  | 24  | 28   | 31   | 35   | 39   | 45   |
|                | 600 x 500            |                             |                |     |     |     |     |      |      |      |      |      |

Symbols:

V<sub>k</sub> - Effective velocity in m/s

Q - Flow rate (l/s)

Pressure (P<sub>t</sub>) - All pressures are in Pa (N/m<sup>2</sup>)

NR - Noise level index in dB based on a room absorption and one diffuser

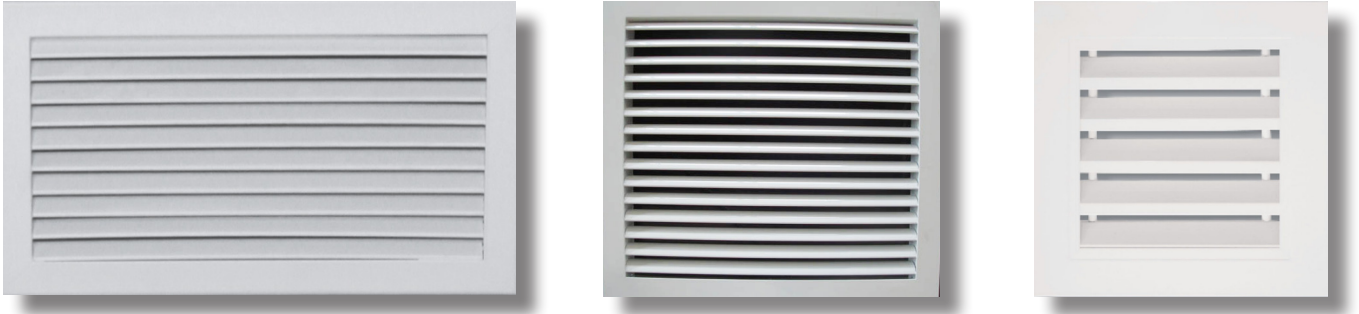

## Half Chevron Louvre

### General Information:

A return air grille is a connection to ductwork that allows air to return to a heating and cooling system. Return air openings are typically covered with grillwork that serves a number of different functions.

### Features:

- For exhaust or return air, having a single set of fixed blades at 45 degree at 17.5mm spacing
- Made of extruded aluminium
- Rigid, heavy gauge extruded frames with reinforced mitered and welded corners
- Optional opposed blade damper
- Surface mounting or concealed mounting
- Powder coated white as standard

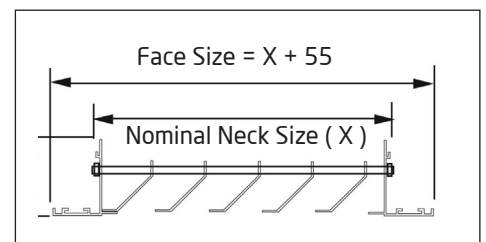
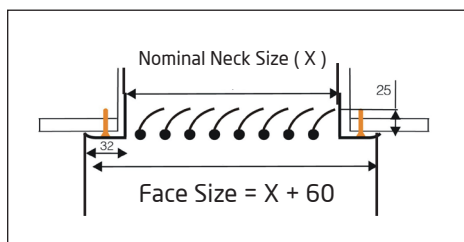
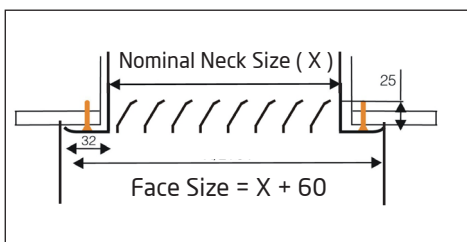

# Return Air Grille

| Nominal Neck (mm)    |                | 150 x 150       |     | 200 x 200       |     | 250 x 250       |     | 300 x 300       |     | 350 x 350       |     | 400 x 400       |    | 450 x 450       |    | 500 x 500       |    |
|----------------------|----------------|-----------------|-----|-----------------|-----|-----------------|-----|-----------------|-----|-----------------|-----|-----------------|----|-----------------|----|-----------------|----|
| Equivalent Size (mm) |                | 225 x 100       |     | 350 x 125       |     | 350 x 175       |     | 350 x 250       |     | 400 x 300       |     | 400 x 350       |    | 500 x 400       |    | 600 x 450       |    |
|                      |                |                 |     |                 |     | 450 x 200       |     | 500 x 250       |     | 550 x 300       |     | 600 x 350       |    | 650 x 400       |    |                 |    |
|                      |                |                 |     |                 |     | 650 x 100       |     | 600 x 150       |     | 600 x 200       |     | 750 x 200       |    | 700 x 300       |    | 750 x 350       |    |
| A <sub>k</sub>       |                | 0.017           |     | 0.034           |     | 0.056           |     | 0.081           |     | 0.11            |     | 0.144           |    | 0.182           |    | 0.225           |    |
| V <sub>k</sub>       | P <sub>t</sub> | Flow Rate (l/s) | NR  | Flow Rate (l/s) | NR  | Flow Rate (l/s) | NR  | Flow Rate (l/s) | NR  | Flow Rate (l/s) | NR  | Flow Rate (l/s) | NR | Flow Rate (l/s) | NR | Flow Rate (l/s) | NR |
| 1.5                  | 7              | 25              | <15 | 51              | <15 | 84              | <15 | 122             | <15 | 165             | <15 | 216             | 15 | 273             | 16 | 338             | 17 |
| 2.0                  | 12             | 34              | 16  | 68              | 23  | 113             | 24  | 162             | 24  | 221             | 25  | 288             | 26 | 365             | 26 | 450             | 27 |
| 2.5                  | 19             | 42              | 21  | 85              | 28  | 141             | 29  | 203             | 29  | 276             | 30  | 360             | 31 | 456             | 31 | 563             | 32 |
| 3.0                  | 28             | 51              | 24  | 102             | 33  | 141             | 34  | 243             | 35  | 331             | 35  | 432             | 36 | 547             | 36 | 675             | 37 |
| 3.5                  | 38             | 59              | 28  | 119             | 35  | 197             | 36  | 284             | 37  | 386             | 37  | 504             | 38 | 638             | 38 | 788             | 39 |
| 4.0                  | 50             | 68              | 34  | 136             | 39  | 253             | 40  | 324             | 40  | 441             | 40  | 576             | 41 | 729             | 41 | 900             | 42 |
| 4.5                  | 63             | 76              | 37  | 153             | 41  | 253             | 42  | 365             | 43  | 496             | 43  | 648             | 44 | 820             | 44 | 1013            | 45 |
| 5.0                  | 77             | 84              | 40  | 170             | 44  | 281             | 45  | 405             | 45  | 551             | 46  | 720             | 46 | 911             | 47 | 1125            | 48 |

| Nominal Neck (mm)    |                | 550 x 550       |    | 600 x 600       |    | 650 x 650       |    | 700 x 700       |    | 750 x 750       |    | 800 x 800       |    | 850 x 850       |    | 900 x 900       |    |
|----------------------|----------------|-----------------|----|-----------------|----|-----------------|----|-----------------|----|-----------------|----|-----------------|----|-----------------|----|-----------------|----|
| Equivalent Size (mm) |                | 600 x 450       |    | 650 x 550       |    | 700 x 600       |    | 750 x 650       |    | 850 x 650       |    | 900 x 700       |    | 900 x 800       |    | 950 x 850       |    |
|                      |                | 650 x 400       |    | 700 x 500       |    | 800 x 450       |    | 1000 x 500      |    | 1200 x 500      |    | 1200 x 550      |    | 950 x 750       |    | 1200 x 650      |    |
|                      |                | 750 x 350       |    | 800 x 450       |    | 1200 x 350      |    | 850 x 550       |    | 1000 x 650      |    | 100 x 650       |    | 1100 x 650      |    | 1000 x 750      |    |
|                      |                | 900 x 300       |    | 900 x 300       |    | —               |    | —               |    | —               |    | —               |    | 1200 x 600      |    | —               |    |
| A <sub>k</sub>       |                | 0.272           |    | 0.324           |    | 0.380           |    | 0.441           |    | 0.506           |    | 0.576           |    | 0.650           |    | 0.729           |    |
| V <sub>k</sub>       | P <sub>t</sub> | Flow Rate (l/s) | NR | Flow Rate (l/s) | NR | Flow Rate (l/s) | NR | Flow Rate (l/s) | NR | Flow Rate (l/s) | NR | Flow Rate (l/s) | NR | Flow Rate (l/s) | NR | Flow Rate (l/s) | NR |
| 1.5                  | 7              | 408             | 18 | 486             | 18 | 570             | 19 | 662             | 20 | 759             | 21 | 864             | 22 | 975             | 23 | 1094            | 23 |
| 2.0                  | 12             | 545             | 28 | 648             | 28 | 761             | 29 | 882             | 30 | 1013            | 30 | 1152            | 31 | 1301            | 32 | 1458            | 32 |
| 2.5                  | 19             | 681             | 33 | 810             | 33 | 951             | 34 | 1103            | 34 | 1266            | 35 | 1440            | 35 | 1626            | 36 | 1823            | 37 |
| 3.0                  | 28             | 817             | 37 | 972             | 37 | 1141            | 38 | 1323            | 38 | 1519            | 39 | 1728            | 39 | 1951            | 40 | 2187            | 41 |
| 3.5                  | 38             | 953             | 39 | 1134            | 40 | 1331            | 40 | 1544            | 41 | 1772            | 41 | 2016            | 42 | 2276            | 43 | 2552            | 43 |
| 4.0                  | 50             | 1089            | 42 | 1296            | 43 | 1521            | 43 | 1764            | 44 | 2025            | 45 | 2304            | 45 | 2601            | 46 | 2916            | 46 |
| 4.5                  | 63             | 1225            | 45 | 1458            | 46 | 1711            | 46 | 1985            | 47 | 2278            | 47 | 2625            | 48 | 2926            | 48 | 3281            | 49 |
| 5.0                  | 77             | 1361            | 48 | 1620            | 49 | 1901            | 49 | 2205            | 50 | 2531            | 50 | 2880            | 51 | 3251            | 51 | 3645            | 52 |

Symbols:

A<sub>k</sub> - Effective area

V<sub>k</sub> - Effective velocity in m/s

Pressure (P<sub>t</sub>) - All pressures are in Pa (N/m<sup>2</sup>)

NR - Noise level index in dB based on a room absorption and one diffuser



## Door Grille

### General Information:

This type of grille is always delivered with a mounting frame, provided with holes for screwing.

The arrangement of the blades in inverted "V", impedes vision through it when applied in doors, partition wall etc.

### Features:

- Made of high quality extruded aluminium profile
- Used for air transfer on doors or walls
- Size manufactured on request
- Suitable for a range of wall/door thicknesses

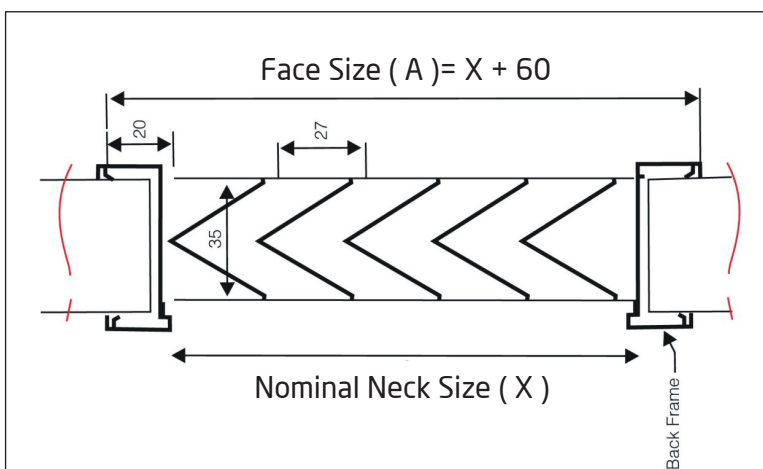

| Nominal Neck Metric ( X ) | Face Size ( A ) |
|---------------------------|-----------------|
| 150 mm                    | 210 mm          |
| 200 mm                    | 260 mm          |
| 250 mm                    | 310 mm          |
| 300 mm                    | 360 mm          |
| 400 mm                    | 460 mm          |
| 450 mm                    | 510 mm          |
| 600 mm                    | 660 mm          |

\* Grilles are powder coated white as standard

\* The first number is for horizontal dimension and the second number is for vertical dimension

## Quick Selection Table

| Flow rate |       | Dim            | 300 x 100 | 400 x 100 | 500 x 150 | 400 x 200 | 500 x 200 | 600 x 200 | 600 x 250 | 600 x 350 | 700 x 400 |
|-----------|-------|----------------|-----------|-----------|-----------|-----------|-----------|-----------|-----------|-----------|-----------|
|           |       |                | 200 x 150 | 200 x 200 | 350 x 200 | 300 x 250 | 400 x 250 | 500 x 250 | 500 x 300 | 500 x 400 | 600 x 500 |
| (m³/h)    | (l/s) | A <sub>k</sub> | 0.0156    | 0.0208    | 0.0390    | 0.0448    | 0.0560    | 0.0684    | 0.0855    | 0.1218    | 0.1652    |
| 50        | 13.9  | V <sub>k</sub> | 0.9       | 0.7       | 0.4       |           |           |           |           |           |           |
|           |       | P <sub>t</sub> | 3.6       | 2.0       | 0.6       |           |           |           |           |           |           |
| 60        | 13.9  | V <sub>k</sub> | 1.1       | 0.8       | 0.4       |           |           |           |           |           |           |
|           |       | P <sub>t</sub> | 5.1       | 2.9       | 0.8       |           |           |           |           |           |           |
| 70        | 16.7  | V <sub>k</sub> | 1.2       | 0.9       | 0.5       | 0.4       |           |           |           |           |           |
|           |       | P <sub>t</sub> | 7.0       | 3.9       | 1.1       | 0.8       |           |           |           |           |           |
| 80        | 19.4  | V <sub>k</sub> | 1.4       | 1.1       | 0.6       | 0.5       | 0.4       |           |           |           |           |
|           |       | P <sub>t</sub> | 9.1       | 5.1       | 1.5       | 1.1       | 0.7       |           |           |           |           |
| 90        | 22.2  | V <sub>k</sub> | 1.6       | 1.2       | 0.6       | 0.6       | 0.4       |           |           |           |           |
|           |       | P <sub>t</sub> | 11.6      | 6.5       | 1.8       | 1.4       | 0.9       |           |           |           |           |
| 100       | 25.0  | V <sub>k</sub> | 1.8       | 1.3       | 0.7       | 0.6       | 0.5       | 0.4       |           |           |           |
|           |       | P <sub>t</sub> | 14.3      | 8.0       | 2.3       | 1.7       | 1.1       | 0.7       |           |           |           |
| 120       | 27.8  | V <sub>k</sub> | 2.1       | 1.6       | 0.9       | 0.7       | 0.6       | 0.5       | 0.4       |           |           |
|           |       | P <sub>t</sub> | 20.5      | 11.6      | 3.3       | 2.5       | 1.6       | 1.1       | 0.7       |           |           |
| 140       | 33.3  | V <sub>k</sub> | 2.5       | 1.9       | 1.0       | 0.9       | 0.7       | 0.6       | 0.5       |           |           |
|           |       | P <sub>t</sub> | 28.0      | 15.7      | 4.5       | 3.4       | 2.2       | 1.5       | 0.9       |           |           |
| 160       | 38.9  | V <sub>k</sub> |           | 2.1       | 1.1       | 1.0       | 0.8       | 0.6       | 0.5       |           |           |
|           |       | P <sub>t</sub> |           | 20.5      | 5.8       | 4.4       | 2.8       | 1.9       | 1.2       |           |           |
| 180       | 44.4  | V <sub>k</sub> |           | 2.4       | 1.3       | 1.1       | 0.9       | 0.7       | 0.6       | 0.4       |           |
|           |       | P <sub>t</sub> |           | 26.0      | 7.4       | 5.6       | 3.6       | 2.4       | 1.5       | 0.8       |           |
| 200       | 50.0  | V <sub>k</sub> |           |           | 1.4       | 1.2       | 1.0       | 0.8       | 0.6       | 0.5       |           |
|           |       | P <sub>t</sub> |           |           | 9.1       | 6.9       | 4.4       | 3.0       | 1.9       | 0.9       |           |
| 250       | 55.6  | V <sub>k</sub> |           |           | 1.8       | 1.6       | 1.2       | 1.0       | 0.8       | 0.6       | 0.4       |
|           |       | P <sub>t</sub> |           |           | 14.3      | 10.8      | 6.9       | 4.6       | 3.0       | 1.5       | 0.8       |
| 300       | 69.4  | V <sub>k</sub> |           |           | 2.1       | 1.9       | 1.5       | 1.2       | 1.0       | 0.7       | 0.5       |
|           |       | P <sub>t</sub> |           |           | 20.5      | 15.6      | 10.0      | 6.7       | 4.3       | 2.1       | 1.1       |
| 350       | 83.3  | V <sub>k</sub> |           |           | 2.5       | 2.2       | 1.7       | 1.4       | 1.1       | 0.8       | 0.6       |
|           |       | P <sub>t</sub> |           |           | 28.0      | 21.2      | 13.6      | 9.1       | 5.8       | 2.9       | 1.6       |
| 400       | 97.2  | V <sub>k</sub> |           |           |           | 2.5       | 2.0       | 1.6       | 1.3       | 0.9       | 0.7       |
|           |       | P <sub>t</sub> |           |           |           | 27.7      | 17.7      | 11.9      | 7.6       | 3.7       | 2.0       |
| 500       | 111.1 | V <sub>k</sub> |           |           |           |           | 2.5       | 2.0       | 1.6       | 1.1       | 0.8       |
|           |       | P <sub>t</sub> |           |           |           |           | 27.7      | 18.6      | 11.9      | 5.9       | 3.2       |
| 600       | 138.9 | V <sub>k</sub> |           |           |           |           |           | 2.4       | 1.9       | 1.4       | 1.0       |
|           |       | P <sub>t</sub> |           |           |           |           |           | 26.7      | 17.1      | 9.4       | 4.6       |
| 700       | 166.7 | V <sub>k</sub> |           |           |           |           |           |           | 2.3       | 1.6       | 1.2       |
|           |       | P <sub>t</sub> |           |           |           |           |           |           | 23.3      | 11.5      | 6.2       |
| 800       | 194.4 | V <sub>k</sub> |           |           |           |           |           |           | 2.6       | 1.8       | 1.3       |
|           |       | P <sub>t</sub> |           |           |           |           |           |           | 30.4      | 15.0      | 8.1       |
| 900       | 222.2 | V <sub>k</sub> |           |           |           |           |           |           |           | 2.1       | 1.5       |
|           |       | P <sub>t</sub> |           |           |           |           |           |           |           | 19.0      | 10.3      |
| 1000      | 250.0 | V <sub>k</sub> |           |           |           |           |           |           |           | 2.3       | 1.7       |
|           |       | P <sub>t</sub> |           |           |           |           |           |           |           | 23.4      | 12.7      |
| 1200      | 277.8 | V <sub>k</sub> |           |           |           |           |           |           |           |           | 2.0       |
|           |       | P <sub>t</sub> |           |           |           |           |           |           |           |           | 18.3      |
| 1400      | 333.3 | V <sub>k</sub> |           |           |           |           |           |           |           |           | 2.4       |
|           |       | P <sub>t</sub> |           |           |           |           |           |           |           |           | 24.9      |
| 1600      | 444.4 | V <sub>k</sub> |           |           |           |           |           |           |           |           | 2.7       |
|           |       | P <sub>t</sub> |           |           |           |           |           |           |           |           | 32.6      |

**Symbols:**

A<sub>k</sub> - Effective area

V<sub>k</sub> - Effective velocity in m/s

Pressure (P<sub>t</sub>) - All pressures are in Pa (N/m²)

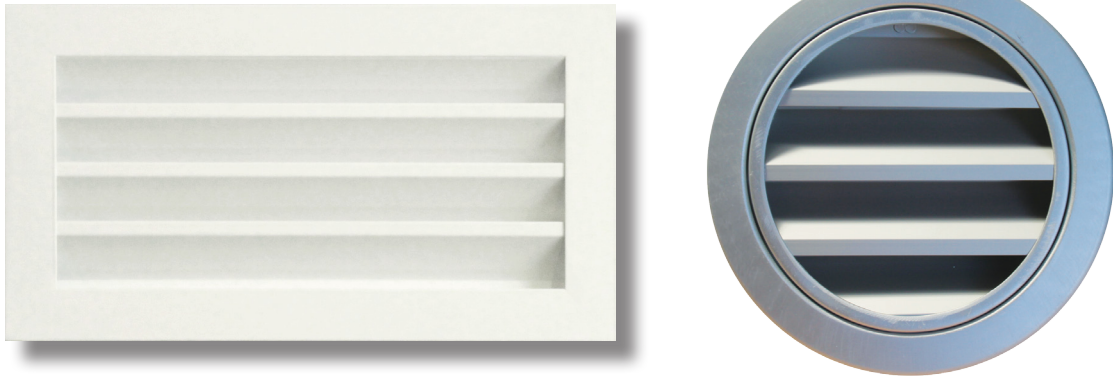

## Weather Proof Louvre

### General Information:

A louvre is a ventilation product that allows air to pass through it while keeping out unwanted elements such as water, dirt, and debris. A number of fixed or operable blades mounted in a frame can provide this functionality. The basic considerations for selecting louvres are Louvre Free Area, air flow and resistance to airflow (Pressure Loss).

### Features:

- Made of high quality aluminium
- Water proof blades design
- Wire vermin mesh provided
- Standard finish: Anodized in Aluminium
- Size manufactured on request

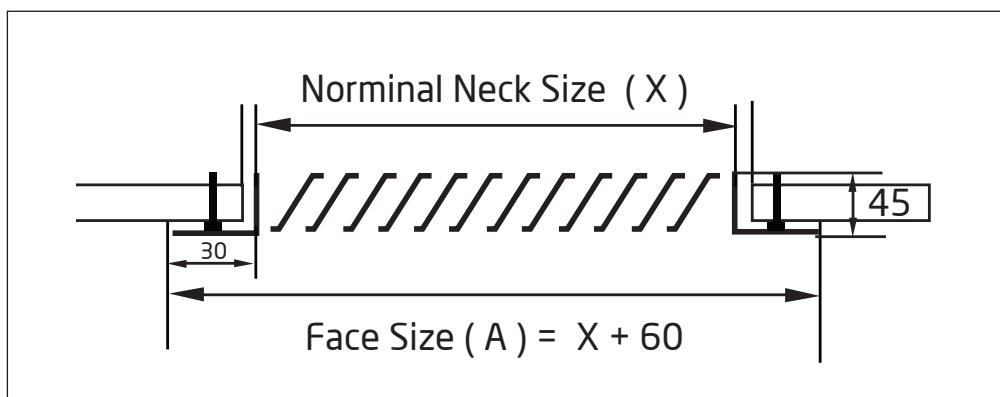

## Quick Selection Table

| Flow rate<br>(m <sup>3</sup> /h) (l/s) |       | Dim            | 200 x 100 | 200 x 100 | 300 x 100 | 400 x 100 | 500 x 100 | 600 x 100 | 500 x 150 | 600 x 150 | 300 x 300 | 800 x 150 | 600 x 200 | 800 x 200 | 1000x200  | 1000x300  | 900 x 400 | 1000x400 |           |  |  |
|--|-------|----------------|-----------|-----------|-----------|-----------|-----------|-----------|-----------|-----------|-----------|-----------|-----------|-----------|-----------|-----------|-----------|----------|-----------|--|--|
|  |       |                |           |           | 200 x 150 | 200 x 200 | 350 x 150 | 400 x 150 | 400 x 200 | 450 x 200 |           |           | 400 x 300 | 500 x 250 | 600 x 250 | 800 x 250 | 750 x 400 |          | 700 x 500 |  |  |
|  |       |                |           |           |           |           | 250 x 200 | 300 x 200 | 300 x 250 | 360 x 250 |           |           |           |           |           |           |           |          | 600 x 500 |  |  |
|  |       | A <sub>k</sub> | 0.0051    | 0.0025    | 0.0079    | 0.0108    | 0.0133    | 0.0215    | 0.0272    | 0.0321    | 0.0402    | 0.0473    | 0.0479    | 0.0664    | 0.0609    | 0.1366    | 0.1758    | 0.01433  |           |  |  |
| 50                                     | 13.9  | V <sub>k</sub> | 2.7       | 2.1       | 1.8       | 1.3       | 1.0       | 0.8       |           |           |           |           |           |           |           |           |           |          |           |  |  |
|  |       | P <sub>t</sub> | 12.0      | 7.4       | 5.0       | 2.7       | 1.8       | 1.0       |           |           |           |           |           |           |           |           |           |          |           |  |  |
|  |       | NR             | 25        | 20        | 16        | 9         | 5         | -1        |           |           |           |           |           |           |           |           |           |          |           |  |  |
| 60                                     | 16.7  | V <sub>k</sub> | 3.3       | 2.6       | 2.1       | 1.5       | 1.3       | 0.9       |           |           |           |           |           |           |           |           |           |          |           |  |  |
|  |       | P <sub>t</sub> | 17.3      | 10.7      | 7.2       | 3.9       | 2.5       | 1.3       |           |           |           |           |           |           |           |           |           |          |           |  |  |
|  |       | NR             | 30        | 25        | 21        | 14        | 10        | 3         |           |           |           |           |           |           |           |           |           |          |           |  |  |
| 70                                     | 19.4  | V <sub>k</sub> | 3.8       | 3.0       | 2.5       | 1.8       | 1.5       | 1.0       |           |           |           |           |           |           |           |           |           |          |           |  |  |
|  |       | P <sub>t</sub> | 23.5      | 14.5      | 9.8       | 5.3       | 3.5       | 1.7       |           |           |           |           |           |           |           |           |           |          |           |  |  |
|  |       | NR             | 34        | 29        | 24        | 18        | 13        | 6         |           |           |           |           |           |           |           |           |           |          |           |  |  |
| 80                                     | 22.2  | V <sub>k</sub> | 4.4       | 3.4       | 2.8       | 2.1       | 1.7       | 1.2       |           |           |           |           |           |           |           |           |           |          |           |  |  |
|  |       | P <sub>t</sub> | 30.8      | 18.9      | 12.8      | 6.9       | 4.5       | 2.2       |           |           |           |           |           |           |           |           |           |          |           |  |  |
|  |       | NR             | 37        | 32        | 28        | 21        | 17        | 9         |           |           |           |           |           |           |           |           |           |          |           |  |  |
| 90                                     | 25.0  | V <sub>k</sub> | 4.9       | 3.8       | 3.2       | 2.3       | 1.9       | 1.3       | 0.9       |           |           |           |           |           |           |           |           |          |           |  |  |
|  |       | P <sub>t</sub> | 38.9      | 24.0      | 16.2      | 8.7       | 5.7       | 2.7       | 1.4       |           |           |           |           |           |           |           |           |          |           |  |  |
|  |       | NR             | 40        | 36        | 31        | 24        | 20        | 12        | 4         |           |           |           |           |           |           |           |           |          |           |  |  |
| 100                                    | 27.8  | V <sub>k</sub> | 5.4       | 4.3       | 3.5       | 2.6       | 2.1       | 2.1       | 1.0       |           |           |           |           |           |           |           |           |          |           |  |  |
|  |       | P <sub>t</sub> | 48.1      | 29.6      | 20.0      | 10.7      | 7.1       | 6.9       | 1.7       |           |           |           |           |           |           |           |           |          |           |  |  |
|  |       | NR             | 43        | 37        | 33        | 27        | 22        | 24        | 7         |           |           |           |           |           |           |           |           |          |           |  |  |
| 160                                    | 44.4  | V <sub>k</sub> |           | 6.8       | 5.5       | 4.1       | 3.3       | 2.6       | 1.6       | 1.4       | 1.1       |           |           |           |           |           |           |          |           |  |  |
|  |       | P <sub>t</sub> |           | 75.5      | 51.3      | 27.4      | 18.1      | 10.8      | 4.3       | 3.1       | 2.0       |           |           |           |           |           |           |          |           |  |  |
|  |       | NR             |           | 49        | 45        | 36        | 34        | 29        | 19        | 15        | 10        |           |           |           |           |           |           |          |           |  |  |
| 200                                    | 55.6  | V <sub>k</sub> |           |           | 7.0       | 5.1       | 4.2       | 3.2       | 2.0       | 1.7       | 1.4       |           |           |           |           |           |           |          |           |  |  |
|  |       | P <sub>t</sub> |           |           | 80.1      | 42.9      | 28.3      | 16.9      | 6.8       | 4.9       | 3.1       |           |           |           |           |           |           |          |           |  |  |
|  |       | NR             |           |           | 50        | 44        | 39        | 36        | 24        | 21        | 16        |           |           |           |           |           |           |          |           |  |  |
| 250                                    | 69.4  | V <sub>k</sub> |           |           |           | 6.4       | 5.2       | 3.9       | 2.6       | 2.2       | 1.7       | 1.5       | 1.4       | 1.0       |           |           |           |          |           |  |  |
|  |       | P <sub>t</sub> |           |           |           | 67.0      | 44.2      | 24.3      | 10.6      | 7.6       | 4.8       | 3.5       | 3.4       | 1.8       |           |           |           |          |           |  |  |
|  |       | NR             |           |           |           | 49        | 45        | 39        | 30        | 26        | 21        | 18        | 18        | 11        |           |           |           |          |           |  |  |
| 300                                    | 83.3  | V <sub>k</sub> |           |           |           |           | 6.3       | 5.2       | 3.1       | 2.6       | 2.1       | 1.8       | 1.7       | 1.3       | 1.0       |           |           |          |           |  |  |
|  |       | P <sub>t</sub> |           |           |           |           | 63.5      | 43.3      | 15.2      | 10.9      | 7.0       | 5.0       | 4.9       | 2.6       | 1.7       |           |           |          |           |  |  |
|  |       | NR             |           |           |           |           | 49        | 46        | 34        | 31        | 26        | 22        | 22        | 15        | 11        |           |           |          |           |  |  |
| 400                                    | 111.1 | V <sub>k</sub> |           |           |           |           |           | 6.5       | 4.1       | 3.5       | 2.8       | 2.3       | 2.3       | 1.7       | 1.4       | 0.8       |           |          |           |  |  |
|  |       | P <sub>t</sub> |           |           |           |           |           |           | 67.6      | 27.0      | 19.4      | 12.4      | 8.9       | 8.7       | 4.5       | 3.1       | 1.1       |          |           |  |  |
|  |       | NR             |           |           |           |           |           |           | 52        | 41        | 38        | 33        | 30        | 29        | 22        | 18        | 7         |          |           |  |  |

**Symbols:**

A<sub>k</sub> - Effective area

V<sub>k</sub> - Effective velocity in m/s

Pressure ( P<sub>t</sub> ) - All pressures are in Pa (N/m<sup>2</sup>)

NR - Noise level index in dB based on a room absorption and one diffuser

## Quick Selection Table

| Flow rate           |       | Dim            | 200 x 100 | 200 x 100 | 300 x 100 | 400 x 100 | 500 x 100 | 600 x 100 | 500 x 150 | 600 x 150 | 300 x 300 | 800 x 150 | 600 x 200 | 800 x 200 | 1000x200  | 1000x300  | 900 x 400 | 1000x400 |         |
|---------------------|-------|----------------|-----------|-----------|-----------|-----------|-----------|-----------|-----------|-----------|-----------|-----------|-----------|-----------|-----------|-----------|-----------|----------|---------|
|                     |       |                |           |           | 200 x 150 | 200 x 200 | 350 x 150 | 400 x 150 | 400 x 200 | 450 x 200 |           |           | 500 x 250 | 600 x 250 | 800 x 250 | 750 x 400 | 700 x 500 |          |         |
| (m <sup>3</sup> /h) | (l/s) | A <sub>k</sub> | 0.0051    | 0.0025    | 0.0079    | 0.0108    | 0.0133    | 0.0215    | 0.0272    | 0.0321    | 0.0402    | 0.0473    | 0.0479    | 0.0664    | 0.0609    |           | 0.1366    | 0.1758   | 0.01433 |
| 500                 | 138.9 | V <sub>k</sub> |           |           |           |           |           | 6.5       | 5.1       | 4.3       | 3.5       | 29        | 2.9       | 2.1       | 1.7       | 1.0       |           |          |         |
|                     |       | P <sub>t</sub> |           |           |           |           |           | 67.6      | 42.2      | 30.3      | 19.3      | 14.0      | 13.6      | 7.1       | 4.8       | 1.7       |           |          |         |
|                     |       | NR             |           |           |           |           |           | 52        | 47        | 43        | 39        | 36        | 36        | 28        | 24        | 13        |           |          |         |
| 600                 | 166.7 | V <sub>k</sub> |           |           |           |           |           |           | 6.1       | 5.2       | 4.1       | 3.5       | 3.5       | 2.5       | 2.1       | 1.2       | 0.9       |          |         |
|                     |       | P <sub>t</sub> |           |           |           |           |           |           | 60.8      | 43.7      | 27.8      | 20.1      | 19.6      | 10.2      | 6.9       | 2.4       | 1.5       |          |         |
|                     |       | NR             |           |           |           |           |           |           | 51        | 48        | 43        | 40        | 39        | 32        | 28        | 17        | 12        |          |         |
| 700                 | 194.4 | V <sub>k</sub> |           |           |           |           |           |           | 7.1       | 6.1       | 4.8       | 4.1       | 4.1       | 2.9       | 2.4       | 1.4       | 1.1       | 0.6      |         |
|                     |       | P <sub>t</sub> |           |           |           |           |           |           | 82.8      | 59.4      | 37.9      | 27.4      | 26.7      | 13.9      | 9.4       | 3.3       | 2.0       | 0.7      |         |
|                     |       | NR             |           |           |           |           |           |           | 55        | 52        | 47        | 43        | 43        | 36        | 32        | 21        | 15        | 4        |         |
| 800                 | 222.2 | V <sub>k</sub> |           |           |           |           |           |           |           | 6.9       | 5.5       | 4.7       | 4.6       | 3.3       | 2.7       | 1.6       | 1.3       | 0.7      |         |
|                     |       | P <sub>t</sub> |           |           |           |           |           |           |           | 77.6      | 49.5      | 36.8      | 34.9      | 18.1      | 12.2      | 4.3       | 2.6       | 0.9      |         |
|                     |       | NR             |           |           |           |           |           |           |           | 56        | 50        | 47        | 46        | 39        | 36        | 24        | 19        | 7        |         |
| 900                 | 250.0 | V <sub>k</sub> |           |           |           |           |           |           |           |           | 6.2       | 5.3       | 5.2       | 3.8       | 3.1       | 1.8       | 1.4       | 0.8      |         |
|                     |       | P <sub>t</sub> |           |           |           |           |           |           |           |           | 62.7      | 45.3      | 44.1      | 23.0      | 15.5      | 5.4       | 3.3       | 1.1      |         |
|                     |       | NR             |           |           |           |           |           |           |           |           | 53        | 50        | 49        | 42        | 38        | 27        | 22        | 10       |         |
| 1000                | 277.8 | V <sub>k</sub> |           |           |           |           |           |           |           |           | 6.9       | 5.9       | 5.8       | 4.2       | 3.4       | 2.0       | 1.6       | 0.9      |         |
|                     |       | P <sub>t</sub> |           |           |           |           |           |           |           |           | 77.3      | 55.9      | 54.5      | 28.4      | 19.1      | 6.7       | 4.0       | 1.4      |         |
|                     |       | NR             |           |           |           |           |           |           |           |           | 56        | 52        | 52        | 45        | 41        | 30        | 24        | 13       |         |
| 1600                | 444.4 | V <sub>k</sub> |           |           |           |           |           |           |           |           |           |           |           |           | 6.7       | 5.5       | 3.3       | 2.5      | 1.5     |
|                     |       | P <sub>t</sub> |           |           |           |           |           |           |           |           |           |           |           |           | 72.6      | 48.9      | 17.2      | 10.4     | 3.6     |
|                     |       | NR             |           |           |           |           |           |           |           |           |           |           |           |           | 57        | 52        | 41        | 36       | 25      |
| 2000                | 566.6 | V <sub>k</sub> |           |           |           |           |           |           |           |           |           |           |           |           | 6.9       | 4.1       | 3.2       | 1.9      |         |
|                     |       | P <sub>t</sub> |           |           |           |           |           |           |           |           |           |           |           |           | 76.4      | 26.5      | 16.2      | 5.5      |         |
|                     |       | NR             |           |           |           |           |           |           |           |           |           |           |           |           | 58        | 47        | 41        | 30       |         |
| 3000                | 833.3 | V <sub>k</sub> |           |           |           |           |           |           |           |           |           |           |           |           |           | 6.1       | 4.7       | 2.8      |         |
|                     |       | P <sub>t</sub> |           |           |           |           |           |           |           |           |           |           |           |           |           | 60.4      | 36.4      | 12.5     |         |
|                     |       | NR             |           |           |           |           |           |           |           |           |           |           |           |           |           | 57        | 51        | 40       |         |
| 3600                | 927.2 | V <sub>k</sub> |           |           |           |           |           |           |           |           |           |           |           |           |           |           | 5.5       | 3.2      |         |
|                     |       | P <sub>t</sub> |           |           |           |           |           |           |           |           |           |           |           |           |           |           | 40.5      | 17.0     |         |
|                     |       | NR             |           |           |           |           |           |           |           |           |           |           |           |           |           |           | 56        | 44       |         |
| 4000                | 1111  | V <sub>k</sub> |           |           |           |           |           |           |           |           |           |           |           |           |           |           | 6.3       | 3.7      |         |
|                     |       | P <sub>t</sub> |           |           |           |           |           |           |           |           |           |           |           |           |           |           | 64.7      | 22.2     |         |
|                     |       | NR             |           |           |           |           |           |           |           |           |           |           |           |           |           |           | 59        | 47       |         |

**Symbols:**

A<sub>k</sub> - Effective area

V<sub>k</sub> - Effective velocity in m/s

Pressure ( P<sub>t</sub> ) - All pressures are in Pa (N/m<sup>2</sup>)

NR - Noise level index in dB based on a room absorption and one diffuser



Butterfly Damper with fixing neck

## Butterfly Damper

### General Information:

A Butterfly Damper is designed for isolation and modulation of flue gas and comes with single and multi blade. Typically installed to isolate and control flue gases, single blade dampers, also could be used for on/off flow control.

### Features:

- Allows for easy control of air quantity for balancing and airflow adjustment
- Made to suit a wide variety of sizes of grilles
- Size manufactured on request
- Dampers are powder coated black as standard

| Nominal Neck Metric ( X ) | Face Size ( A ) |
|---------------------------|-----------------|
| 225 x 225 mm              | 150 mm          |
| 225 x 225 mm              | 200 mm          |
| 300 x 300 mm              | 300 mm          |
| 300 x 300 mm              | 250 mm          |
| 300 x 300 mm              | 300 mm          |

\* Grilles are powder coated white as standard

\* Length dimension can be modified based on different specification.



## Opposite Blades Damper

### General Information:

Opposed Blade Dampers contain steel parts, and are therefore not recommended for use in corrosive environments. If you require a volume control damper suitable for these environments why not look at our uPVC Volume Control Damper, with exceptional corrosion resistance thanks to its plastic construction.

### Features:

- Made of high quality extruded aluminium profile
- Used as damper for square diffuser
- Accurate gear wheel control, screwdriver adjustment
- Size manufactured on request

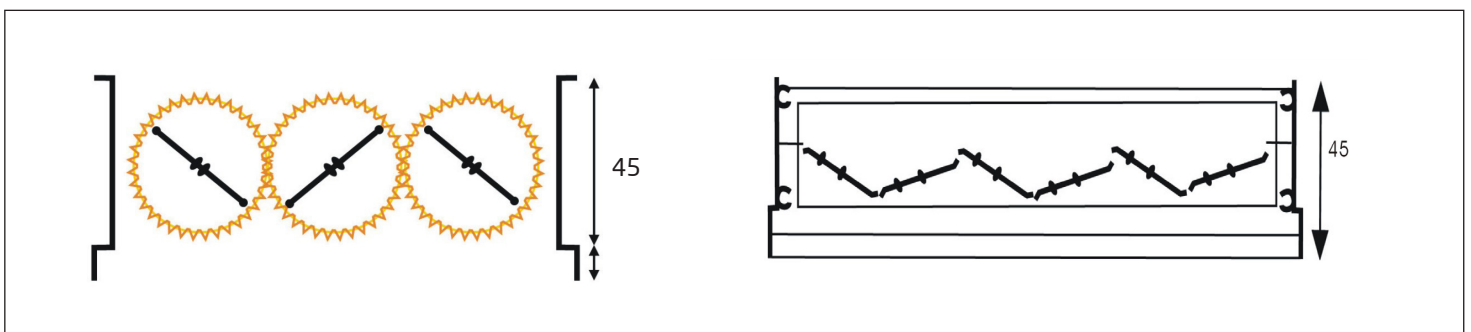

| Nominal Neck Metric |              |
|---------------------|--------------|
|                     | 300 x 300 mm |
|                     | 400 x 300 mm |
|                     | 500 x 300 mm |
|                     | 600 x 300 mm |

\* Grilles are powder coated white as standard

\* Length dimension can be modified based on different specification.

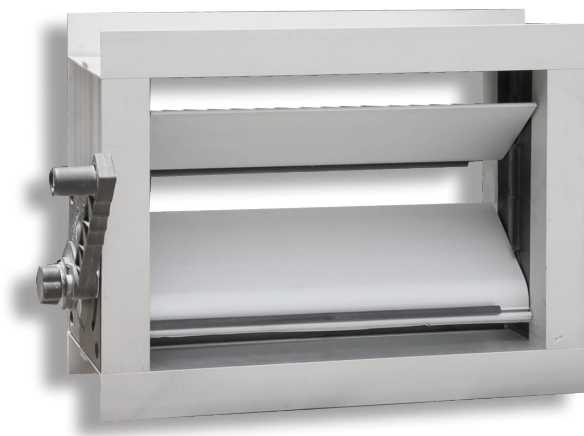

## Volume Control Damper

### General Information:

These Volume Control Dampers are suitable for regulating or shutting off the air flow in air ducts with rectangular or square cross-sections. The blades are manufactured from aluminium profiles and the frame is produced from galvanized steel sheets. The blade action is realised with the help of gears by a linkage mechanism. All of the dampers are produced either with damper actuators or with actuator bases or with a manual locking quadrant.

### Features:

- Frame depth is 152mm
- Flange is 35mm
- Side seals & Blade seals (optional)
- High temperature seals also available for smoke relief
- Size manufactured on request

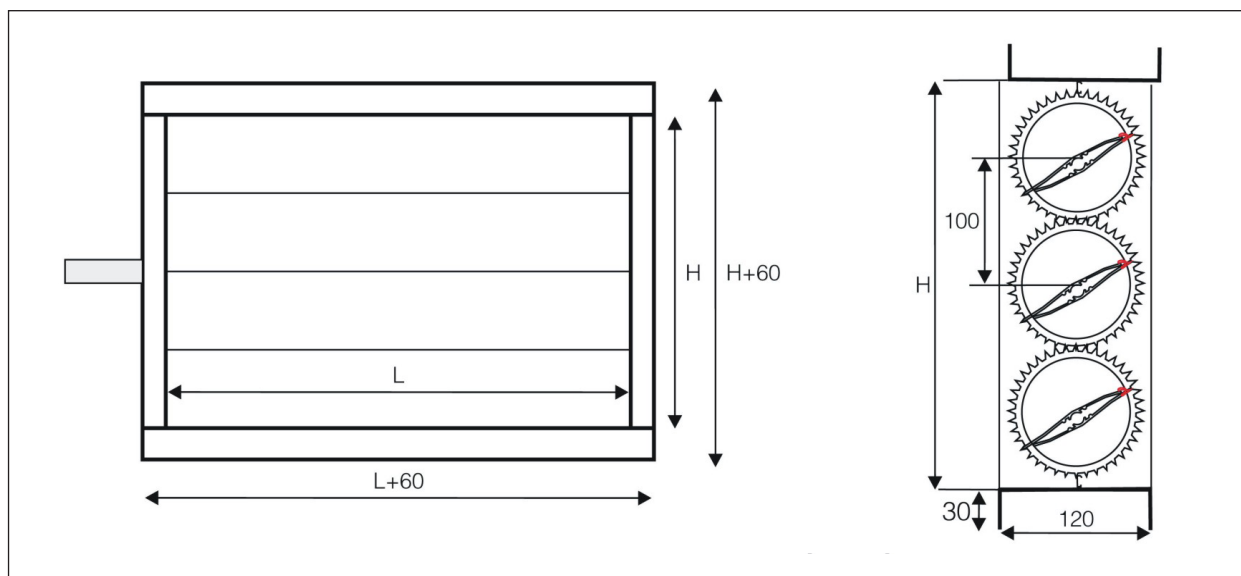



## Motorised Zone Damper

### General Information:

Motored Zone Dampers are suitable for regulating or shutting off the air flow in air ducts with circular cross-section. The blade and the housing is manufactured from hot-dipped galvanized sheets. The shaft is made from carbon steel and the bushing is made from special plastic. Standard blade is single thickness and the blade actuating mechanism is either, manual metal or plastic handle with locking mechanism or with base for at site actuator assembling.

### Features:

- Adjustable damper position range stops
- Single-blade damper
- Shipped as power closed/spring return open damper
- Galvanized steel
- Can be field-converted to power open/spring return closed damper
- Blade closes off tightly against gasket for minimal leakage
- Male (crimped) and female (un-crimped) ends to connect to any rigid or flexible round duct

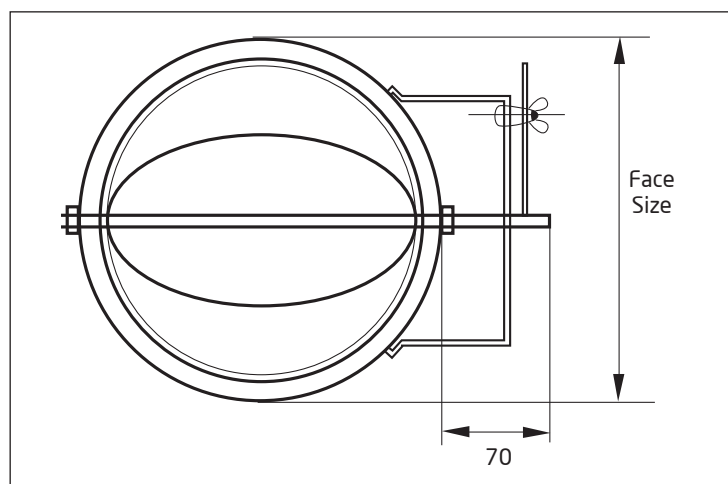



## Stream Splitter Damper

### General Information:

The method employed to achieve a reasonably straight air flow and obtain volume control is to use a Stream Splitter Damper.

That should be fixed where the outlet connection to the grille joins the main supply duct in order to turn the air and provide a uniform distribution of air over the face of the grille. Alternatively, the SSD can be made as an integral part of the register to allow direct fixing to the main duct.

### Features:

- Construction: All zinc anneal construction
- Accessories: Rectangular to oval adaptors
- Finish available: Matt black enamel

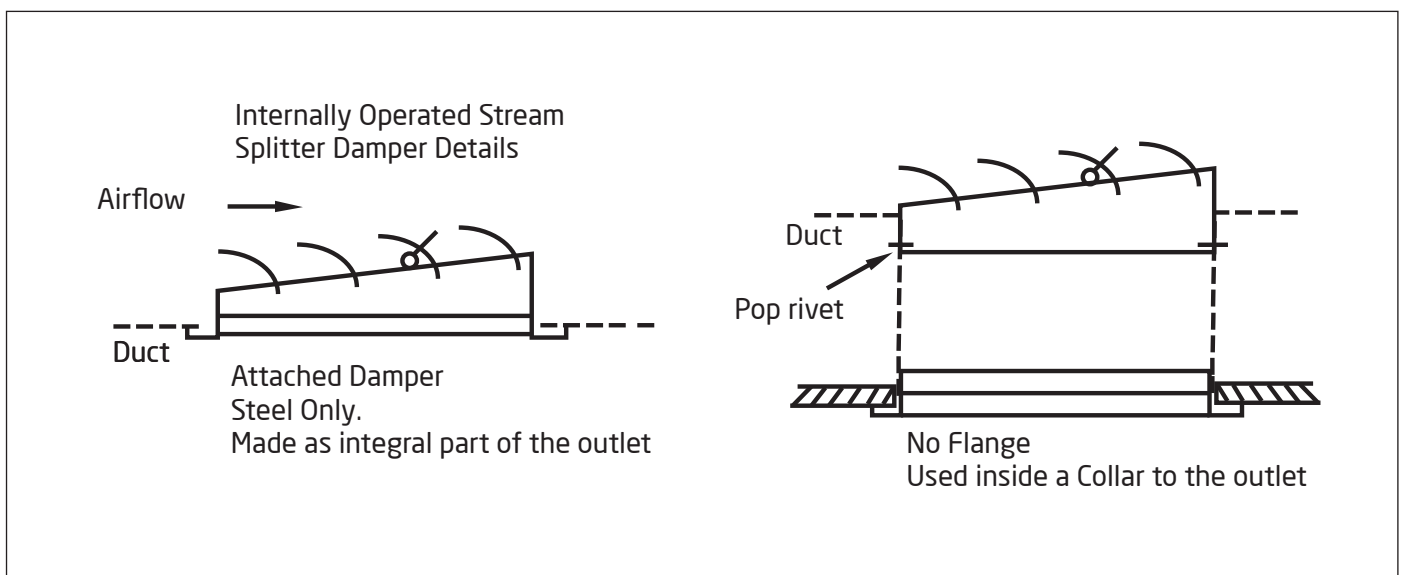



# VENTECH

**Grilles, Diffusers, Dampers  
Cushion boxes**

## **Ventech (Australia) Pty Ltd**

VIC Factory :

25 Kembla Street, Cheltenham, 3192

VIC For Sales

Phone: (03) 9583 2400

Fax: (03) 9583 2400

Email: sales@ventechgrilles.com.au

For General Enquiries

Phone: (03) 9583 2400

Email: info@ventechgrilles.com.au

## **Ventech (China):**

**Ventech Air Conditioning Co.,Ltd**

No.6, West 7 Industrial Road, Jiangcun, Leliu,  
Shunde, Guangdong, China

Phone: (+86) -757-29200198

Fax: (+86) -757-25561256

Email: sales@chinaventech.com

## **National Distributors:**

### **Interstate offices:**

NSW & ACT Office

Phone: (02) 9674 1577

Fax: (02) 9674 1588

Email: daniel@ducttech.com.au

QLD Office

Phone: (07) 3890 8796

Fax: (07) 3890 8642

Email: salesqld@dunnair.com.au

SA&NT Office

Phone: (08) 8240 2888

Fax: (08) 8240 2777

Email: salessa@dunnair.com.au

TAS Office

Phone: 0408 409 342

Fax: (03) 6425 3531

Email: salestas@dunnair.com.au

**[www.ventechgrilles.com.au](http://www.ventechgrilles.com.au)**

**[www.chinaventech.com](http://www.chinaventech.com)**